

COVAL

vacuum managers

Vacuum Guide



ADVANCED VACUUM SOLUTIONS

www.coval.com

EN2

Contents

Suction Cups

Selection Guide	p. 3-6
Suction Cup Assembly Options	p. 7
Assembly Reference: "Suction Cup + Fitting"	p. 8
The COVAL Range	p. 9-11
Index of Pictograms and Symbols	p. 12

Applications

Sizing the vacuum generator	p. 13
Applications for airtight products	p. 14-15
Applications for porous products	p. 16-18
Vacuum network	p. 19-20
Compressed air network	p. 21
Reminder	p. 22
FAQ	p. 23

Suction Cups

Selection Guide

A suction cup is a gripper which can be used to handle all sorts of objects of different weights, surfaces, shapes and sizes.

For this reason we feel it would be helpful to explain all the parameters to be taken into consideration, in order to choose the right suction cup.

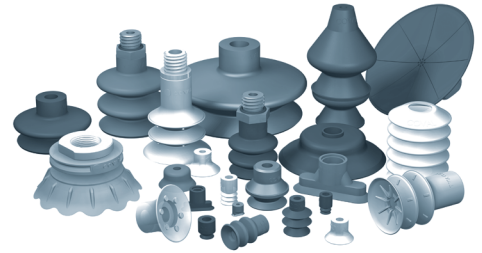

PARAMETERS TO BE TAKEN INTO CONSIDERATION WHEN CHOOSING A SUCTION CUP

Shape of the load	Flat • Rounded • Cylindrical • Egg-shaped • Spherical, etc.
Type of material of the load	Porous • Porous • Deformable • Rigid • Fragile, etc.
Condition of the surface of the load	Smooth • Granular • Ridged • Abrasive, etc
Appearance of the load	Damp • Oily • Dusty • Viscous • Dry, etc
Weight of the load	Heavy • Light, etc.
Temperature of the load	From -40 to 250°C / -40 to 482°F depending on the materials chosen.
Direction of gripping	Horizontal • Vertical • Over corners • Height differences, etc.
Type of grip	Handling • Lifting • Holding • Unfolding ... objects.
Available surface	Depending on the load
Cycle time	Accelerations

THE SHAPES

Flat Suction Cups

■ Flat suction cups without cleats
Used for handling flat or slightly rounded, rigid, smooth objects. They withstand lateral forces and can be used for vertical handling.

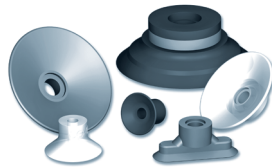

■ Flat suction cups with cleats
Used for handling thin, flexible, deformable objects. They increase resistance to lateral forces and horizontal handling.

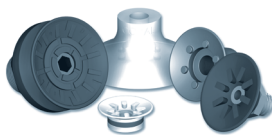

Suction Cups with Bellows

Used to handle spherical, cylindrical or egg-shaped objects. The effect of the technical characteristics increases with the number of bellows.

They can be used for gripping objects with height differences, for a ball-joint effect, to lift and to grip corners or edges.



SUCTION CUP FORCE CALCULATION

The force of a suction cup is proportional to its surface under vacuum and also depends on its shape, flexibility, material and especially on the level of vacuum attained inside the suction cup.

Theoretical force

$$F(\text{DaN}) = S (\text{cm}^2) \times V (\%) \times 0,01013$$

S = Surface of the suction cup (cm²)
V = Vacuum level (%)

Actual force

As its name implies, this force represents the actual force of the suction cup when in use. In general this is 50% less than the calculated theoretical force.

This difference is explained by the distortion of the suction cup during handling (which reduces the gripping surface), and by the condition of the surface of the object being handled.

The safety factor

All holding forces are listed in the data tables for each range of suction cup. These are **actual values at 65% vacuum**, calculated with a safety factor of:

- 2 for horizontal gripping (1),
- 4 for vertical gripping (2).

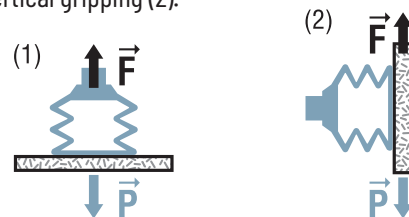

For applications involving high acceleration, the safety factor will be calculated accordingly.

Suction Cups

Selection Guide

SUCTION CUP TECHNICAL DATA

Diameters

The force of the suction cup and the product's available gripping surface depend on this parameter. COVAL offers standard suction cups of 1 to 600mm in diameter across the product ranges.



Internal volume

This corresponds to the volume which must be evacuated during a vacuum cycle. It must be accounted for in the total volume of the gripping system and thus in the suction time calculation.



Minimum bend radius

This indicates the minimum radius of a product to be reliably gripped by the suction cup.



Stroke

This corresponds to the compression of the suction cup during the vacuum cycle.

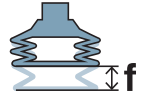

COVAL MATERIALS

To meet the constraints of industrial applications, COVAL has a wide range of both standard and specific materials. COVAL can also study new materials based on specific requirements of your applications.

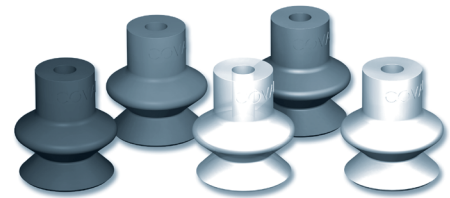

Properties of the materials

Materials	Abbreviation	Shore Hardness A (+/- 5 Shore A)	Color	Flexibility	Abrasion resistance	UV & weather resistance	Mineral oil resistance	Continuous temperature resistance		Food compatibility	
								in °C	in °F	FDA CFR 21 177.2600	CE 1935/2004
Nitrile	NBR	60	Black	+	++	+	++	0 to 90	32 to 194		
Silicone	SI	35	Translucent	++++	-	+++	-	-40 to 220	-40 to 428	■	■
	SI3	35	Red	++++	-	+++	-	-40 to 220	-40 to 428	■	■
	SI5	50	Translucent	+++	-	+++	-	-40 to 220	-40 to 428	■	■
	SIB	35	White	++++	-	+++	-	-40 to 220	-40 to 428	■	■
	SIBL3	35	Light blue	++++	-	+++	-	-40 to 220	-40 to 428	■	■
	SIBL5	50	Dark blue	+++	-	+++	-	-40 to 220	-40 to 428	■	■
	SI5BD (detectable)	50	Dark blue	+++	-	+++	-	-40 to 220	-40 to 428	■	■
	SIT3	35	Translucent	++++	-	+++	-	-40 to 220	-40 to 428	■	■
	SIT5	50	Translucent	+++	-	+++	-	-40 to 220	-40 to 428	■	■
	SIT6	60	Translucent	++	-	+++	-	-40 to 220	-40 to 428	■	■
Natural Rubber	NR	50	Grey - Brown	+++	++	-	-	-20 to 70	-4 to 158		
SITON®	STN	60	Blue	+	+++	++	++	-20 to 130 ^(*)	-4 to 266 ^(*)		
	STN5	50	Blue	++	+++	++	++	-20 to 130 ^(*)	-4 to 266 ^(*)		
	STN6	60	Green	+	+++	++	++	-20 to 130 ^(*)	-4 to 266 ^(*)		
Polyurethane	PU	60	Blue	+	+++	+	+++	-20 to 90	-4 to 194		
	TPU	85	Blue grey	-	+++	+	+++	-20 to 100	-4 to 212		

(*) Resistance to temperature on a single contact point (< 5 s): 160 °C / 320 °F

- ++++ Excellent
- +++ Very good
- ++ Good
- + Weak
- Not applicable
- Compatible

Suction Cups

Selection Guide

► SITON® MATERIAL SUCTION CUPS

SITON®, developed and manufactured exclusively by COVAL, is a non-marking silicone-free material specially designed for handling hot plastic parts from injection molds.

Advantages of SITON® material

- Non-marking: clear, silicone-free compound.
- Withstands continuous temperatures of 130°C (266°F) up to 160°C (320°F) at peak.
- Excellent abrasion resistance.

Many suction cup models are available in SITON® 60 Shore A (STN) in this catalog.

For greater flexibility, models in SITON® 50 Shore A (STN5) are available upon request.



Temperature range for COVAL materials

Each material has a specific temperature range of use:

- range for extended use.
- range for occasional use (contact time < 5s).

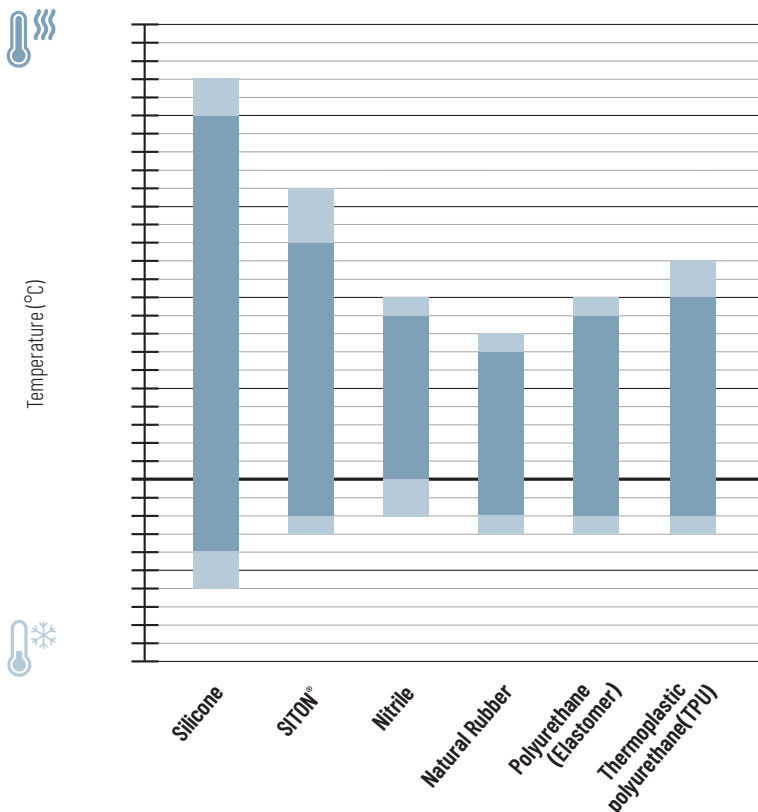

Use of suction cups outside their temperature range of use, wear, damage (cracking) or permanent change of shape (high temperatures) can appear.



Chemicals may be incompatible with the suction cup material and cause swelling or damage.

Suction Cups

Selection Guide

Characteristics of COVAL materials

NITRILE (NBR)

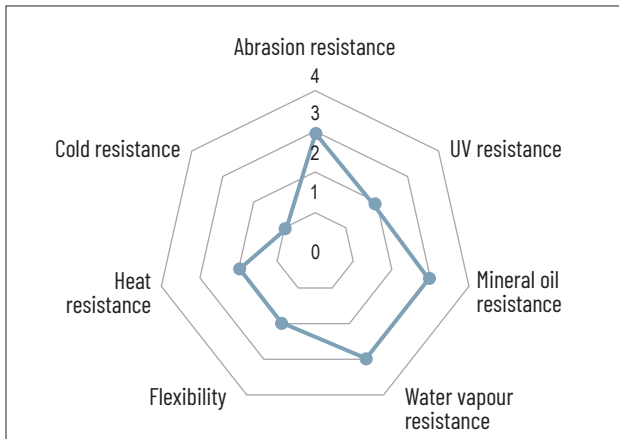

SITON® (STN)

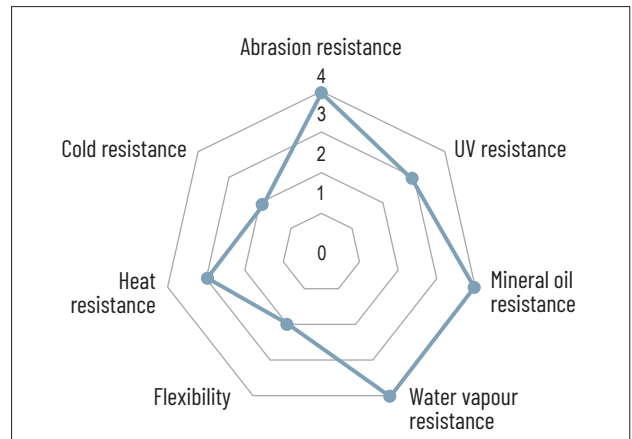

NATURAL RUBBER (NR)

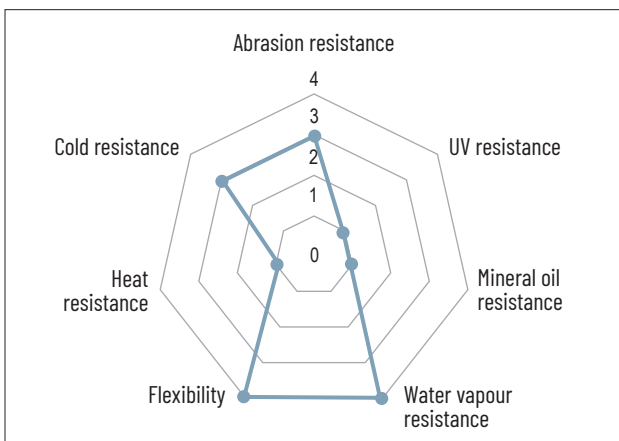

SILICONE (SI_SIT_SIB_SIBL)

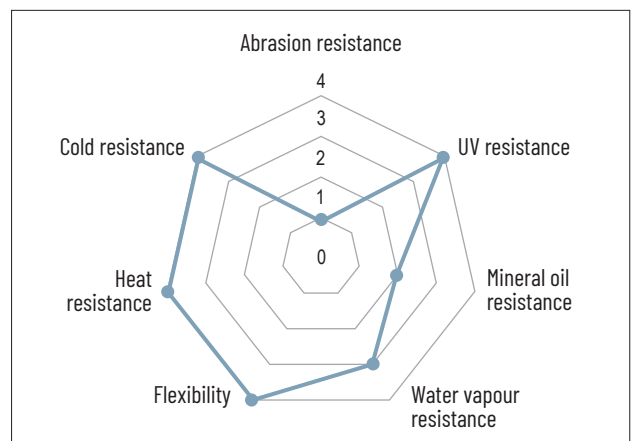

POLYURETHANE (PU)

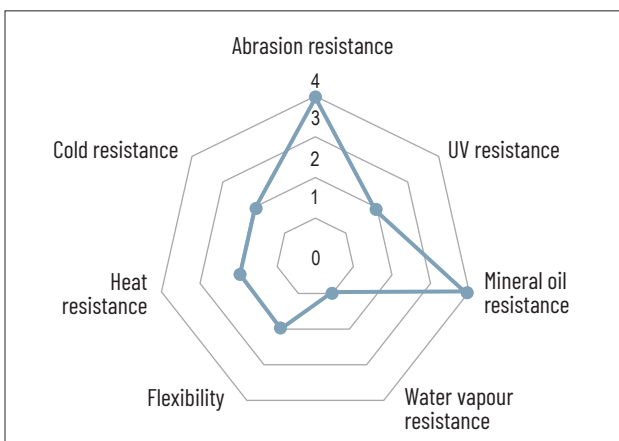

THERMOPLASTIC POLYURETHANE (TPU)

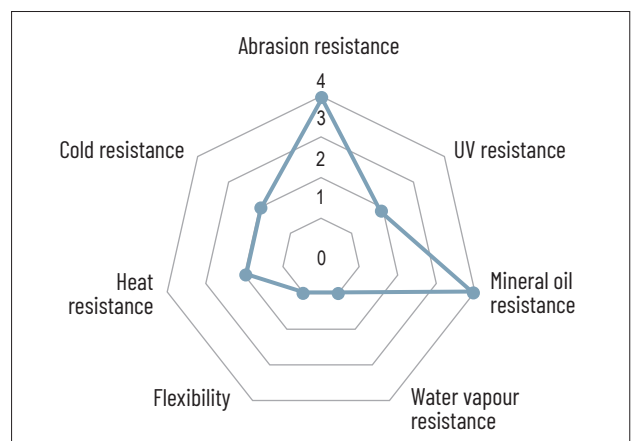

Suction Cups

Suction Cup Fitting Options

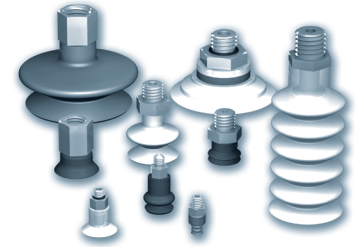

Standard Configuration Options

COVAL suction cups offer versatile mounting and fitting options:

Version C:
Barbed fittings.

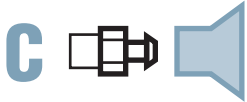

The suction cup is easily pressed onto the fitting.
The suction cups and their fittings are delivered unassembled.

Types of use:

- Lightweight products.
- Horizontal handling.
- For suction cups belonging to groups 1 and 2.

Advantages:

- Quickest changeout of suction cups without the need for tools, improving efficiency.
- Fitting can be reused, thus reducing replacement costs.

Version V:
2-piece removable fittings
(hollow screws and adapter)

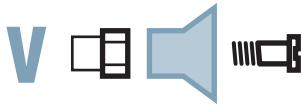

The V mounting utilizes a hollow screw passing through the suction cup and connecting to an adaptor on the opposite side, fixing the suction cup in place.
The suction cups and their fittings are delivered unassembled.

Types of use:

- Heavy and lightweight products.
- Horizontal, vertical and rotational handling.
- For suction cups belonging to groups 2 and 3.

Advantages:

- Excellent mechanical grip of the suction cup.
- Excellent vacuum sealing of the assembly.
- Fitting can be reused, thus reducing replacement costs.

Version E:
Pressed fitting
(removable).

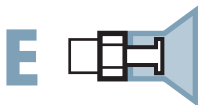

The fitting is factory pressed onto the suction cup.

Types of use:

- Lightweight and heavy products.
- Horizontal, vertical and rotational handling.
- Recommended for handling of porous products.
- For suction cups belonging to group 2.

Advantages:

- Excellent mechanical grip of the suction cup.
- Excellent vacuum sealing of the assembly.
- Greater potential vacuum flow rate when handling porous products.

Version S:
Factory-cripped fitting

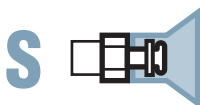

The fitting is factory-cripped onto the suction cup, ensuring a one-piece assembly.

Types of use:

- Heavy and lightweight products.
- Horizontal handling, vertical and rotational.
- Recommended for handling of porous products (when greater flow is required).
- For suction cups belonging to group 3.

Advantages:

- Excellent mechanical grip of the suction cup.
- Excellent vacuum sealing of the assembly.
- Greater potential vacuum flow rate when handling porous products.

Suction Cups

Configuration Reference

"Suction Cup + Fitting"

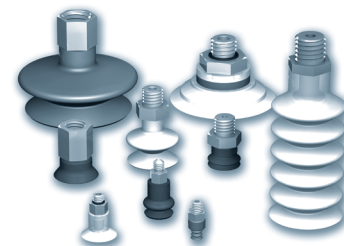

Referencing

To simplify selection of fittings for standard suction cups, a male or female fitting option can be found in the example table, "**Choice of fitting**".

To demonstrate assembly options, reference the example below, **Standard configurations** (suction cup + fitting) which indicates full part numbers as well as **non-standard configurations**.

Ex :

Choice of Fittings

⌀ (mm)	Group	M3-M	M5-M	M6-M	M8-M	M10-M	G1/8"-F	G1/8"-M	10/32-M	G1/4"-F	G1/4"-M	G3/8"-M	G1/2"-M
5	1	■	-	-	-	-	-	-	-	-	-	-	-
11...25	1	-	■	■	-	-	■	■	□	-	-	-	-
26...63	2	-	□	□	□	□	■	■	-	■	■	-	-
78	3	-	-	-	-	□	-	■	-	■	■	□	□

■ Standard configurations (suction cup + fitting)

□ Non-standard mounting configurations

Fitting: M = male F = female

Standard configurations (suction cup + fitting) now have a single part number, simplifying your stock management and order fulfillment.

Ex :

Group 3	THREAD	V			S	
		G1/8"-M	G1/4"-M	G1/4"-F	G1/4"-M	G1/4"-F
Ø 78 mm	VSA78NBR	VSA78NBRIM18V	VSA78NBRIM14V	VSA78NBRIF14V	VSA78NBRIM14	VSA78NBRIF14
	VSA78NR	VSA78NRIM18V	VSA78NRIM14V	VSA78NRIF14V	VSA78NRIM14	VSA78NRIF14
	VSA78SIT5	VSA78SIT5IM18V	VSA78SIT5IM14V	VSA78SIT5IF14V	VSA78SIT5IM14	VSA78SIT5IF14
	VSA78STN	VSA78STNIM18V	VSA78STNIM14V	VSA78STNIF14V	VSA78STNIM14	VSA78STNIF14

Note:

For standard configurations (suction cup + fittings), the C and V versions are delivered unassembled.

Additional mounting configurations are available. You can find all options on pages "assembly diagrams"

Ex :

Removable fitting

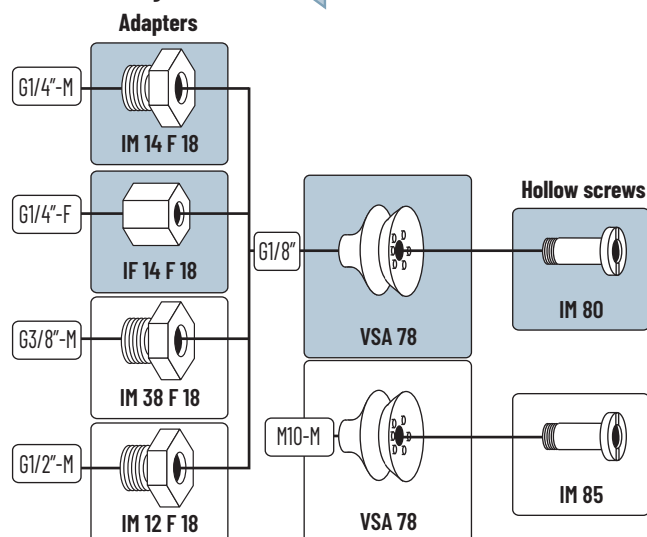

■ Standard configurations (suction cup + fitting).

□ Non-standard configurations must be ordered in separate part numbers.

Suction Cups















The COVAL Range



Standard Suction Cups

Standard suction cups are suitable for all types of applications in various sectors like packaging, plastics, agri-food, sheet-metal working, etc.

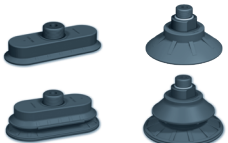
These suction cups satisfy very diverse specifications thanks to a wide range of shapes, diameters and materials. COVAL offers a full range of fittings adapted to suction cups and compatible with all types of applications.

Flat Suction Cups			
VP		<ul style="list-style-type: none"> ■ Ø 8 to 75 mm ■ 4 standard materials 	<ul style="list-style-type: none"> ■ High tensile force and precise gripping and releasing ■ High resistance to lateral forces allowing vertical handling
VPG		<ul style="list-style-type: none"> ■ Extra-flat suction cups ■ Ø 2 to 200 mm ■ 3 standard materials 	<ul style="list-style-type: none"> ■ Highly precise gripping and releasing of the load ■ High throughput rates
VPU		<ul style="list-style-type: none"> ■ Ø 6 to 50 mm ■ 3 standard materials 	<ul style="list-style-type: none"> ■ Suitable for gripping rigid and flat products
VPF		<ul style="list-style-type: none"> ■ Flat suction cups with cleats ■ Ø 15 to 50 mm ■ 3 standard materials 	<ul style="list-style-type: none"> ■ Suitable for gripping rigid and flat products ■ Cleats prevent the deformation of the product and provide excellent non-slip properties
VPO		<ul style="list-style-type: none"> ■ Flat oblong suction cups ■ From 2x4 mm to 30x90 mm ■ 3 standard materials 	<ul style="list-style-type: none"> ■ Used for handling elongated products such as pens, tubes, bottles, bulbs and flat or cylindrical objects etc.
Suction Cups with 1.5 Bellows			
VSA		<ul style="list-style-type: none"> ■ Ø 5 to 78 mm ■ 5 standard materials 	<ul style="list-style-type: none"> ■ Combines the advantages of flat suction cups with added angle, flexibility and precision ■ Used for gripping slightly concave or convex parts
VSAB		<ul style="list-style-type: none"> ■ Ø 5 to 50 mm ■ 3 standard materials 	<ul style="list-style-type: none"> ■ Used for gripping slightly concave or convex parts ■ Suitable for gripping products of various heights
VSAG		<ul style="list-style-type: none"> ■ Ø 10 to 150 mm ■ 3 standard materials 	<ul style="list-style-type: none"> ■ Recommended for gripping sensitive products due to the cushioning effect of the bellows ■ Used for gripping slightly concave or convex parts
VSAJ		<ul style="list-style-type: none"> ■ Ø 15 to 30 mm ■ 2 standard materials 	<ul style="list-style-type: none"> ■ Used for gripping slightly concave or convex parts ■ Suitable for gripping products of various heights
Suction Cups with 2.5 Bellows			
VS		<ul style="list-style-type: none"> ■ Ø 5 to 88 mm ■ 4 standard materials 	<ul style="list-style-type: none"> ■ Recommended for gripping products on different planes (wide deflection) or cylindrical objects gripped at an angle (ball-joint effect).
VSG		<ul style="list-style-type: none"> ■ Ø 5 and 7mm ■ 3 standard materials 	<ul style="list-style-type: none"> ■ Suitable for gripping small products, concave or convex ■ Ideal for handling sensitive products
Long Stroke Suction Cups			
VSD		<ul style="list-style-type: none"> ■ Suction cups with 4.5 and 5.5 bellows ■ 2 standard materials 	<ul style="list-style-type: none"> ■ Strongly recommended for handling spherical or cylindrical products requiring a large height adjustment.
High-performance Suction Cups			
C		<ul style="list-style-type: none"> ■ Full range of shapes (flat, bellows, oblongs) ■ Ø 35 to 125mm and 25x65mm to 70x140mm ■ Integrated fittings ■ Structure and internal cleats 	<ul style="list-style-type: none"> ■ Textured suction cups for gripping thin sheets ■ Non-slip cleats ensure optimum positioning of oily sheet metal ■ Extreme resistance to slipping, ■ Porous integrated fittings ■ Ideal for automated applications
CTC		<ul style="list-style-type: none"> ■ High-Performance Bell-type Suction Cups in Thermoplastic Polyurethane (TPU) ■ 4 models (Ø40 à 100 mm) ■ Integrated fittings ■ Structure and internal cleats 	<ul style="list-style-type: none"> ■ Excellent adaptation to convex surfaces and angular shapes. ■ High deflection compared to standard flat suction cups due to the bell shape. ■ Anti-slip cleats ensure precise positioning of oily sheets. ■ Ideal for automated applications
Suction Cups with Foam Rings			
VSA-VS BM VSA-VS BM-SIF VSBM		<ul style="list-style-type: none"> ■ Foam rings ■ Can be adapted to standard suction cups ■ 2 standard materials 	<ul style="list-style-type: none"> ■ Bonded under a suction cup to allow products with an irregular or even-ridged surface to be gripped ■ Sawn wood, sheet metal, flat surfaces with bumps or hollows (all types of granular surface)

Suction Cups

The COVAL Range



Special Purpose Suction Cups

Thanks to a technological mastery and collaboration with its customers in different branches, COVAL supplies solutions for vacuum handling via a wide range of special purpose suction cups.

E.g. handling eggs, flexible bags, raw composite, bottles, paper, cakes, etc.

FlowPack Suction Cups		
FPC		<ul style="list-style-type: none"> ■ Flexible suction cups ■ 4 models ■ Food-safe materials ■ Silicone: FDA and CE standard <ul style="list-style-type: none"> ■ Range specially designed for gripping flexible packaging ■ Thin and wavy lips mold perfectly to any shape of packaging ■ Gripping ability allows for high production rates
Soft Suction Cups for High Speed Applications		
MVS		<ul style="list-style-type: none"> ■ Suction cups with 1.5 and 2.5 bellows ■ 9 models ■ Silicone: FDA and CE standard <ul style="list-style-type: none"> ■ Used to grip delicate objects. Very flexible lip (opening bags, gripping tins and flexible aluminum or plastic bottles, etc.). ■ High throughput rate ■ Used to grip of flexible products
Suction Cups with 4.5 Bellows		
MVP		<ul style="list-style-type: none"> ■ Suction cups with 4.5 bellows ■ 4 diameters available: 20 to 50 mm ■ Materials: nitrile and silicone (FDA and CE standards) <ul style="list-style-type: none"> ■ The handling of raw food or flexible packaging ■ Thin and flexible shaped lip for a perfect handling at high production rates ■ The 4.5 bellows give a swivelling effect
Suction Cups for Cheese		
VSAF		<ul style="list-style-type: none"> ■ Suction cup with 1.5 bellows ■ Ø 50 mm ■ Silicone: FDA and CE standard <ul style="list-style-type: none"> ■ Suction cup specially designed for gripping fragile foods such as soft cheese ■ Accessory: Stainless steel grill prevents deformation of the food
VSAOF		<ul style="list-style-type: none"> ■ Oval suction cup with 1.5 bellows ■ Dim. 65x150 mm ■ Silicone: FDA and CE standard <ul style="list-style-type: none"> ■ Suction cup specially designed for gripping fragile foods such as soft cheese ■ Accessory: Stainless steel grill prevents deformation of the food
Suction Cups for Bakery Applications		
VSD VSE VSP		<ul style="list-style-type: none"> ■ Suction cups with 2.5 to 5.5 bellows ■ 11 models ■ Silicone: FDA and CE standard <ul style="list-style-type: none"> ■ Range specially developed for gripping delicate objects such as cakes (buns, biscuits, etc.) ■ Specific shapes and shore A hardness depending on the applications ■ Resistance to temperature: - 40 °C to + 220 °C
Suction Cups for Egg-handling		
VSO		<ul style="list-style-type: none"> ■ Suction cups with 2.5 and 3.5 bellows ■ 3 models ■ Silicone: FDA and CE standard 1935/2004 <ul style="list-style-type: none"> ■ Range specially designed to meet constraints involved when handling eggs ■ Very flexible lip ■ Different shapes of suction cup
Suction Cups for Bottle Handling		
VSBO VSBO+ VSBO LM/BM		<ul style="list-style-type: none"> ■ Suction cups with 4.5 bellows ■ 8 models ■ High tensile force ■ Highly flexible and long stroke <ul style="list-style-type: none"> ■ Used to grip 750 ml bottles, Magnums bottles and special bottles with textured surfaces ■ Bottles gripped from the side, vertical and horizontal handling ■ Suction cup with stainless steel reinforcement in the bellows ■ Available with integrated sensing valve
VBO		<ul style="list-style-type: none"> ■ Suction cup system comprised of a 62mm cup with 2.5 bellows and a silicone gripping disc (COVAL-Flex). <ul style="list-style-type: none"> ■ The VBO suction cup system is designed for gripping bottles by the punt on disgorging stations ■ Excellent sealing when gripping different types of bottles
VPBO		<ul style="list-style-type: none"> ■ Coupler Plates for gripping bottles by the punt ■ 3 diameters: Ø65, 75 and 95 mm ■ Natural rubber <ul style="list-style-type: none"> ■ The VPBO Coupler Plates are designed for gripping bottles by the punt on disgorging stations (1/2 bottles, 75cl bottles and Magnum)











Suction Cups

The COVAL Range

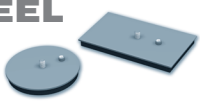

Special Purpose Suction Cups

Suction Cups for Paper Applications			
VPA		<ul style="list-style-type: none"> ■ Flat suction cups ■ 9 models ■ Very flexible lip ■ Natural rubber and silicone (FDA and CE standard) 	<ul style="list-style-type: none"> ■ Range of suction cups with very flexible lip used to handle very flexible materials ■ Very resistant to abrasion (for paper, cardboard) ■ Very flexible gripping lip which molds to the shape of the object to be handled
VPAL		<ul style="list-style-type: none"> ■ Extra-flat shape suction cups ■ 3 models ■ Material: silicone (food compatibility) 	<ul style="list-style-type: none"> ■ The VPAL suction cups are especially adapted for gripping and handling IML labels or flexible materials ■ Great lip flexibility
VSAPL		<ul style="list-style-type: none"> ■ Suction cup with 1.5 bellows ■ Ø 11 mm ■ Silicone: FDA and CE standard 	<ul style="list-style-type: none"> ■ The VSAPL suction cup is especially adapted for gripping and handling IML labels or flexible materials ■ Great lip flexibility
VPR		<ul style="list-style-type: none"> ■ Flat suction cups ■ 4 models ■ Natural rubber 	<ul style="list-style-type: none"> ■ Range of suction cups designed to meet the requirements of mailing applications. ■ Envelope stuffing, film-wrapping, mailing (picking) ■ Very resistant to abrasion
VPAG		<ul style="list-style-type: none"> ■ Curved suction cups ■ 2 models ■ Natural rubber 	<ul style="list-style-type: none"> ■ Thanks to very flexible lips and a curved shape, the VPAG range is adapted to gripping flexible materials such as labels or sheets of paper - or textured objects ■ Very resistant to abrasion
Ultra-flat, Non-Marking Suction Cups			
VPSC		<ul style="list-style-type: none"> ■ Ultra-flat suction cups ■ Ø 40 and 80 mm ■ Materials : Polyurethane and silicone (FDA and CE standards) 	<ul style="list-style-type: none"> ■ Suction cups specially designed not to deform the product being handled. ■ Vacuum distributed across the entire surface of the suction cup for an optimal gripping force. ■ Extra-thin sealing lip designed to contour to the shape of the product being handled
Radial Ball-joint Suction Cups			
VPYR		<ul style="list-style-type: none"> ■ Flat suction cups with ball-joint system ■ 4 models (Ø 50 to 100mm) ■ Materials: nitrile and silicone 	<ul style="list-style-type: none"> ■ The range of ball-joint suction cups is recommended for gripping curved or rotating products which requires a lot of force and mechanical resistance
"Heavy-load" Suction Cups			
SPL		<ul style="list-style-type: none"> ■ "Heavy load" flat suction cups ■ 5 models (Ø 240 to 600mm) ■ Materials: nitrile and silicone 	<ul style="list-style-type: none"> ■ SPL suction cups are used to handle heavy loads such as sheet metal or glass panels. They have internal cleats allowing them to handle thin metal sheets without distorting them and for vertical handling (non-slip)
STEEL		<ul style="list-style-type: none"> ■ Flat suction cups with a bonded foam seal ■ 9 round models (Ø 150 to 580 mm) ■ 9 rectangular models (175x115 to 705x385mm) 	<ul style="list-style-type: none"> ■ For horizontal handling of heavy loads (thick sheet metal) or objects with an uneven surface such as concrete slabs, wood, etc. ■ Wide choice of dimensions

Suction Cups

Index of Symbols and Pictograms



You will find the symbols and pictograms described below in the "Suction cups" chapters to help you select the range of suction cups best suited to your application.

Industry-specific Applications

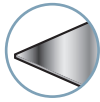

Metal

For handling rigid, smooth, flat objects (e.g. Sheet metal, glass or plastic panels).

- Heavy loads
- Oily objects
- High throughput
- High acceleration



Food-processing

Handling that requires materials which are compatible with food standards, highly flexible lips and suction cup shapes that do not damage fragile products.

- Handling of raw products such as cheese, meat, fish or packaged products.



Plastic

For handling plastic objects and requiring resistance to high temperatures, mark-free (e.g. COVAL-developed material, Siton®).

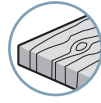

Wood

For handling materials with a slightly deformed, rough gripping surface requiring a foam seal to compensate for the unevenness and ensure porousness.



Eggs

For handling requiring food compatibility, a very flexible lip and a specific shape of suction cup.

- Gripping eggs



Cakes

For handling requiring food compatibility, a very flexible lip and a specific shape of suction cup.

- Gripping buns, biscuits, etc.



Bottles

Gripping concave shapes and requiring strong vertical lifting force.

- For handling 750 ml bottles or Magnums



Paper/picking

For handling paper, and labels and requiring high resistance to abrasion and a very flexible lip to grip flexible materials.

- Envelope filling, film-wrapping

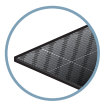

Composite materials

Gripping of raw composite materials.

- No material migration
- No marking of the composite product

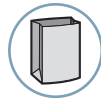

Bags

Gripping very flexible, deformable materials (plastic or paper).

- e.g. blister pack, bagging, etc.

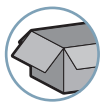

Packaging

For handling wrapped products for packaging, cardboard products. Cardboard shaping, palletization, transfer, Pick & Place.

- Precision
- Abrasion

Types of Use



Flat surfaces,
all thicknesses



Flat surfaces,
thin layers



Rounded
surfaces



Sheet metal
(unstacking)



Flexible
materials



Vertical
handling



Granular
surfaces

Tables

Model or reference	Internal volume	Tensile force	Slipping force	Minimum convex curve radius	Minimum concave curve radius	Weight	See page

Applications

Sizing of the vacuum generator

The sizing of the vacuum generator depends on the constraints of your application. There are two typical applications:

■ Applications for airtight products (p.14)



METAL



PLASTIC



GLASS

■ Applications for porous products (p.16)



WOOD

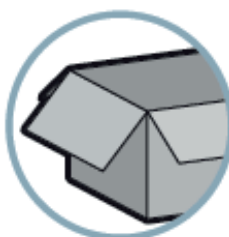

PACKAGING



PAPER/PICKING

Applications

Airtight products

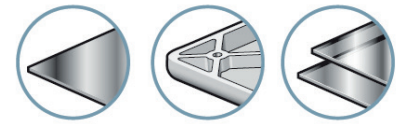

1. Gripping airtight products

In the case of gripping airtight products, a high vacuum level is required to increase the gripping force of the suction cups.

→ Vacuum generator with a vacuum of 88% should be considered.

Therefore, the suction flow should be the criteria used to reduce evacuation time.

Main criteria: evacuation time

In this case, it's the only factor to be considered.

→ It is inversely proportional to the consumption.

The evacuation time is increasing exponentially with the vacuum level
This can be explained by the rarefaction of the air during evacuation

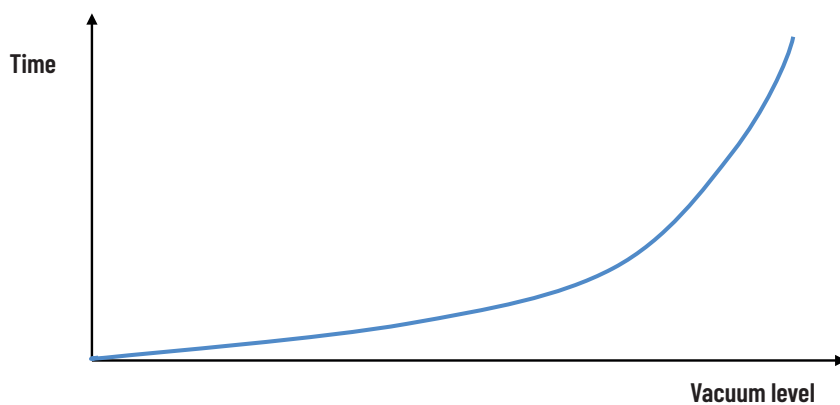
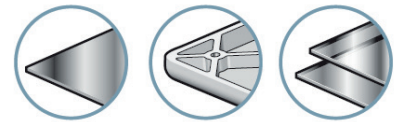

Chart of evacuation time in second for 1L (available in the general documentation)

∅ Nozzle (mm)	20%	40%	60%	80%
0.5	2	4,6	8,8	19
0.7	1	2,3	4,3	8,6
0.9	0,7	1,5	2,9	5,7
1.0	0,5	1,2	2,2	4,4
1.2	0,3	0,7	1,3	2,6
1.4	0,21	0,5	0,9	1,9
1.5	0,20	0,46	0,85	1,7
2.0	0,12	0,28	0,5	1
2.5	0,07	0,16	0,3	0,6
3.0	0,05	0,12	0,23	0,45
CMS 100	0,01	0,03	0,11	0,3

Applications

Airtight products



For airtight products, it is recommended to use vacuum pumps with ASC (Air Saving Control) technology, which can save up to 99% of compressed air. ASC (Air Saving Control) technology, which allows up to 99% savings in compressed air.

Principle of vacuum regulation ASC

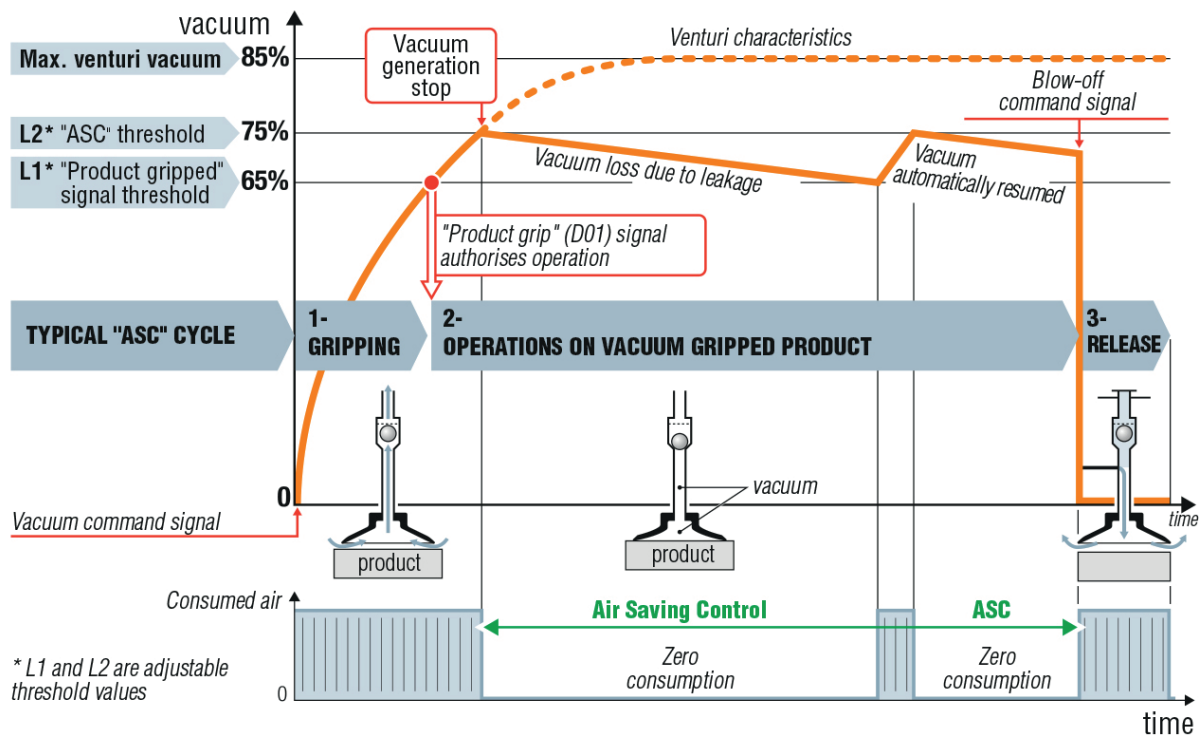

For airtight or semi-airtight products, the vacuum pumps with ASC automatically run the above "ASC" cycle, thus resulting in maximum energy savings, according to the following three phases:

1 - Object is gripped: vacuum generated by the Venturi pump.

2 - Operations on object held in place by vacuum: at the L2 vacuum threshold (75%), the supply of the Venturi pump is cut off → the consumption becomes zero; the object remains held in place due to the non-return valve. If micro-leaks make the vacuum drop to threshold L2 less the defined hysteresis value, vacuum generation is briefly switched on again.

AUTO-ADJUSTMENT: At each cycle, the ASC analyzes the level of leakage and adapts itself. Example: In the case of flexible production requiring the handling of porous products, the ASC detects the leaks, and immediately adapts the vacuum pump operation terminating the cycle without vacuum regulation.

3 - Object is released: by an external or an automatic timed blow-off command (according to the settings).

Maximum energy savings



on airtight or semi-airtight products

→ **90%**

of compressed air saving on average.



We recommend the use of intelligent vacuum pumps of the series: **LEMAX, LEMAXIO, LEMAX +, LEMCOM, GVMAXHD**

ENERGY SAVING APP

Calculate the savings you can generate with our ASC technology using our ENERGY SAVING APP available online.



Applications

Porous products

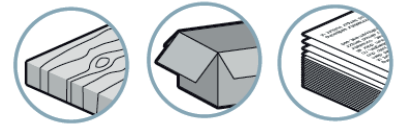

2. Gripping for porous products

Choice of vacuum generator

The most penalising parameter is the leakage rate due to the porosity of the handling products. In this case, it is compulsory to choose a vacuum generator able to supply enough flow rate (at the required vacuum level) to compensate the leakage due to the porosity of the product.

Practical test is always better than theoretical study and it can be done using a master venturi which will be used to quantify the leakage rate through the product.

Procedure for performing a porosity test (opposite page).

Main criteria:

- Vacuum threshold necessary for the gripping
→ The higher it will be, the more powerful the vacuum generator should be
- Porosity of the application
→ It is necessary to make a porosity test to evaluate the leakage per cup.

Required vacuum threshold :

It possible to use the «cross product» method to determine the force at different vacuum levels

$$F1 \quad \times \quad V1\%$$

$$F2? \quad \times \quad V2\%$$





$$F2 = F1 \times V2 / V1 \quad (F = \text{force}, V = \text{Vacuum level})$$

ex : F1= 20N at 65% vacuum, calculator F2 with 40% vacuum.

Example with the characteristics chart of the 1.5 bellows vacuum cups, series VSA.

Available in the general catalog

- F2 = 20 x 40 / 65
- F2 = 12,3 N
- F2 ≈ 1,23 Kg

Suction Cup Properties										
	∅ (mm)	 (cm ³)	 (N) ⁽¹⁾	 (N) ⁽¹⁾	 (mm)	NBR	SIT5	SIB	NR	STN ⁽²⁾
VSA 5	5.5	0.04	0.5	0.2	10	VSA5NBR	VSA5SIT5	-	-	VSA5STN
VSA 11	11	0.225	1.7	0.9	10	VSA11NBR	VSA11SIT5	-	VSA11NR	VSA11STN
VSA 14	13	0.42	2.5	1.3	13	VSA14NBR	VSA14SIT5	-	VSA14NR	VSA14STN
VSA 16	16	0.75	2.7	1.3	20	VSA16NBR	VSA16SIT5	VSA16SIB	VSA16NR	VSA16STN
VSA 18	18	0.76	4.4	2.2	25	VSA18NBR	VSA18SIT5	VSA18SIB	VSA18NR	VSA18STN
VSA 20	19	1.15	5.6	2.8	30	VSA20NBR	VSA20SIT5	VSA20SIB	VSA20NR	VSA20STN
VSA 22	22	1.4	6.1	3.1	25	VSA22NBR	VSA22SIT5	VSA22SIB	VSA22NR	VSA22STN
VSA 25	24	3.15	7.9	4.0	20	VSA25NBR	VSA25SIT5	VSA25SIB	VSA25NR	VSA25STN
VSA 26	25	3.9	10.8	5.4	30	VSA26NBR	VSA26SIT5	-	VSA26NR	VSA26STN
VSA 33	33	4.75	13.9	6.9	40	VSA33NBR	VSA33SIT5	-	VSA33NR	VSA33STN
VSA 43	43	9.25	20.2	10.1	60	VSA43NBR	VSA43SIT5	-	VSA43NR	VSA43STN
VSA 53	53	26.25	42.6	21.3	75	VSA53NBR	VSA53SIT5	-	VSA53NR	VSA53STN
VSA 63	63	39.0	59.2	29.6	75	VSA63NBR	VSA63SIT5	-	VSA63NR	VSA63STN
VSA 78	78	76.0	109.8	54.9	70	VSA78NBR	VSA78SIT5	-	VSA78NR	VSA78STN

(1) Actual force of the suction cup in use with 65% vacuum and including a safety factor of 2 for horizontal handling and a factor of 4 for vertical handling.

Applications

Porous products

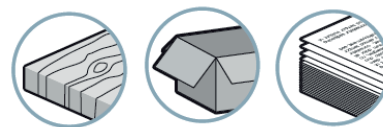

Procedure for performing a porosity test using the VR07TEST

→ Step 1:

- Connect a pressure of 6 bars to the venturi (represented by letter P)
- Connect the selected suction cup (represented by letter V)



→ Step 2:

- Check that your assembly is perfectly tight by testing the suction cup on a smooth and flat surface. The target vacuum value should be between 85 and 88% vacuum.



→ Step 3:

- Test the surface of your product to be handled and note the vacuum value obtained. In order to have a reliable and accurate result, please test several areas of your product.



Applications

Porous product

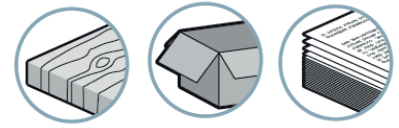

Example of porosity evaluation and determination of suction cups and vacuum generator:

Application: Horizontal gripping of a 12kg cardboard box.

- Choice of suction cups, VSA series, because they combine the advantages of flat suction cups (strength), with more stroke (1.5 bellows)
- Number of suction cups: 6 to distribute the efforts and not to deform the cardboard
- Choice of Ø Suction cups:

$$\frac{\text{12kg load capacity}}{\text{Number of suction cups}} = 2\text{kg (see of characteristics chart of VSA series suction cups 2kg at 65\% vacuum)} \rightarrow \text{VSA43 (\text{Ø} 43\text{mm})}$$

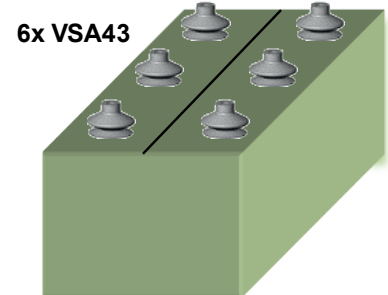

Step 1: Determine material porosity

Measure the leakage rate with only one selected suction cup (e.g. VSA43NR) and the **Venturi Test VR07TEST** (available in the VACUOKIT case) at a supply pressure of **5 bar**.

(The VR07TEST is a In-line Ejector equipped with an electronic Vacuostat with display allowing a quick reading of the vacuum level obtained).

Once the **porosity test** has been performed, transfer the vacuum level obtained on the **Suction flow rate/vacuum curves**: of the VR07 on the catalog (see curve opposite) the **vacuum level** obtained on your sample, this will indicate the **leakage rate**.

In this case, the leakage rate is 7.5NI/min for one suction cup, that is $6 \times 7.5 = 45\text{NI/min}$ for the 6 suction cups needed.

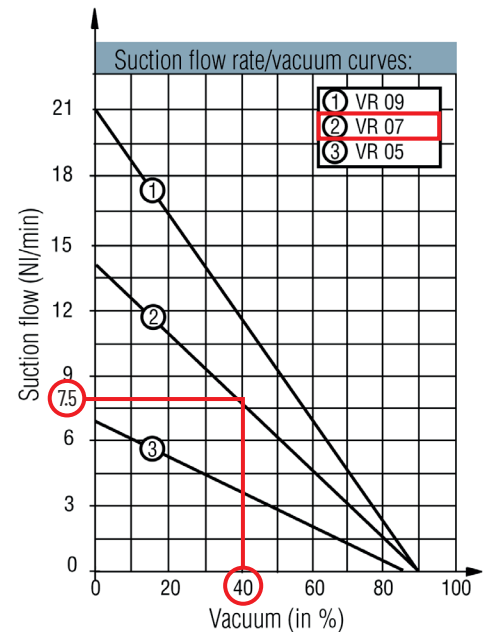

Step 2: Determine the required suction flow rate

Find the **suitable vacuum pump** based on the **minimum suction flow rate** to compensate leaks and the required vacuum level.

Reminder:

- Leakage rate to compensate: **45NI/min**
- Minimum vacuum for the force required for the 6 suction cups: **65%**

Once you have selected the range of vacuum pumps according to the desired functions, enter the vacuum level and the desired suction flow rate on the **Flow/Vacuum curves** and mark the curve crossing your points

Thus, you determine the **vacuum generator** with a sufficient suction flow to **compensate the porosity of the material** and to obtain a vacuum level of 65% allowing the suction cups to **guarantee the gripping of the cardboard**.

Result: LEM90X25

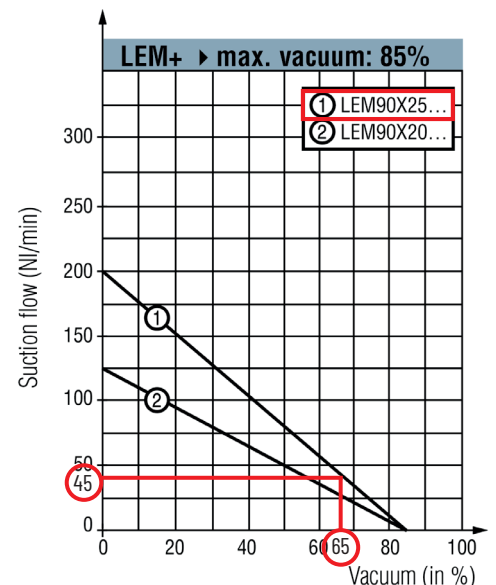

Vacuum network

Building rules

The vacuum network architecture must respect essential rules to ensure optimal performance.

- Symmetrical repartition
- Suction cup positioning as close as possible to the vacuum generator
- Avoid 90° bends and restrictions
- Limit the tube length
- Consistency in the choice of tube diameters according to the below sizing chart
- Extend the network keeping the section of the initial tube

Ex: 1 tube $\varnothing 12$ (113 mm^2) is divided into 4 tubes $\varnothing 6$ (113 mm^2)

Reminder: $S = \pi R^2$

Tube sizing chart for vacuum network

To respect a remaining vacuum of maxi 10% (suction cups not in gripping position)

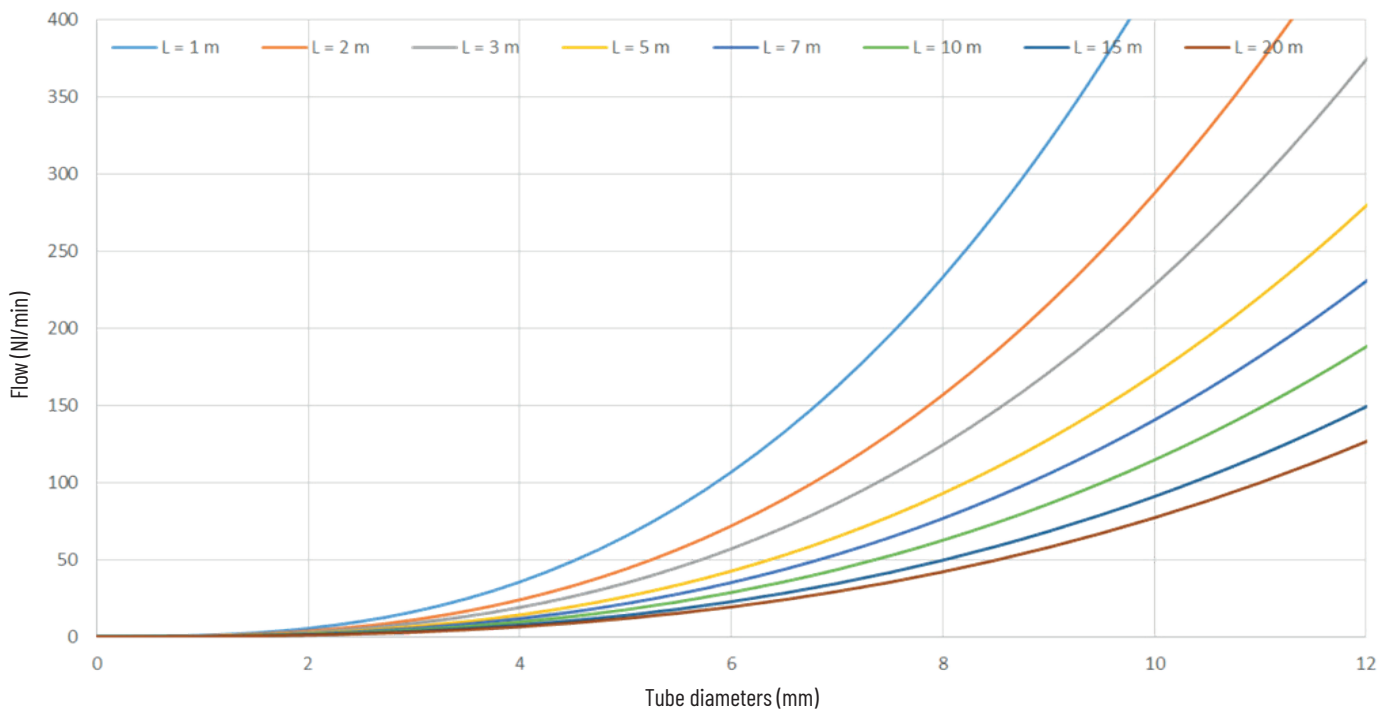

Vacuum network

Network type: « Waterfall »

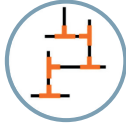

The use of a multitude of T-fittings, and the use of the same \varnothing of Tube from the power supply of the to the suction cups creates important pressure losses and does not allow to diffuse the vacuum and blowoff for release in optimal conditions.

Network type : Star



The use of a larger tube diameter to ensure the supply of the gripper and a central distribution manifold makes the gripper's behaviour much more homogeneous by limiting the pressure losses.

Advantages:

- Reduced evacuation time
- Reduced of the release time
- Homogeneity of the behaviour of the suction cups and release

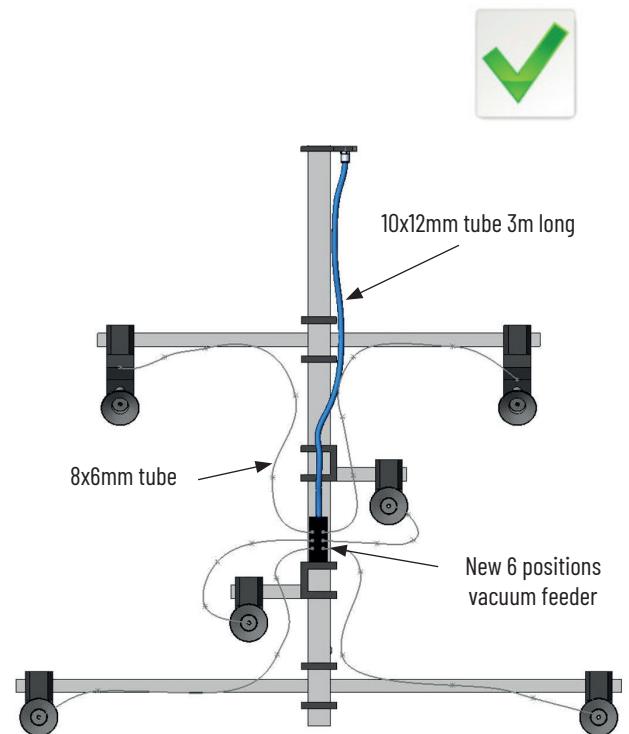
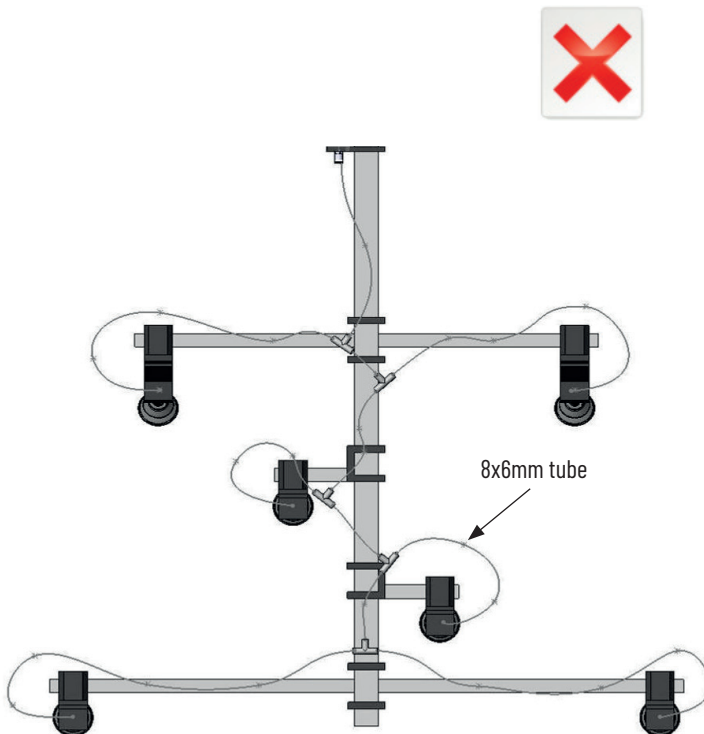

Compressed air network

Building regulations

Integrate the maximum consumed flow rate once all the machine's components work in the same time.

Air quality according ISO 8573-1 Class 4 standard (filtration 5μ). Dry air, non lubricated. If necessary, use filters, oil and water separators before the vacuum generator.

Check that the compressor is correctly dimensioned according to the simplified formula:

10Nm³/h of pneumatic consumption
≈
1kW of power required by the compressor

Tube sizing chart for pressure network

To respect a ΔP of maxi 0,5 b with input pressure of 5,5b

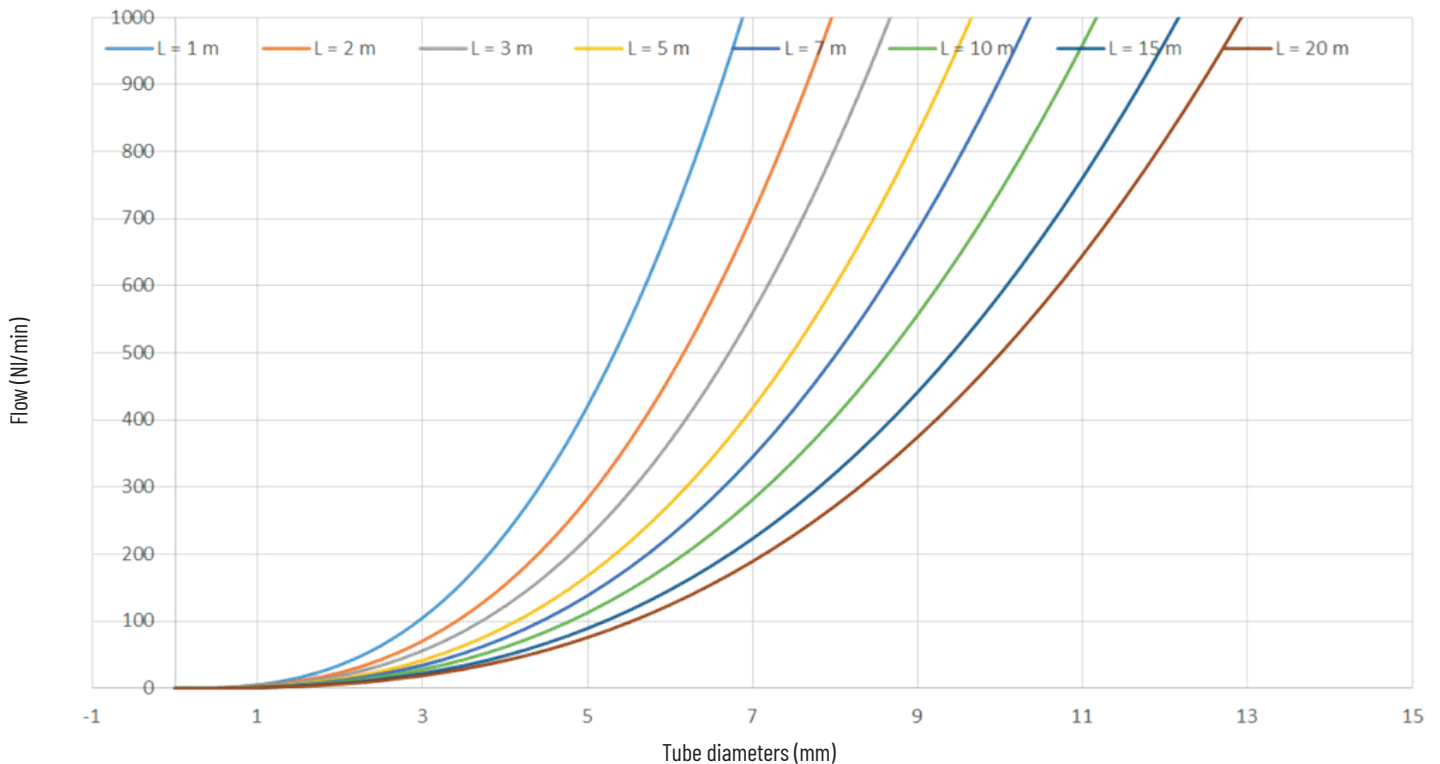

Reminder

The 5 steps to respect for optimal performance

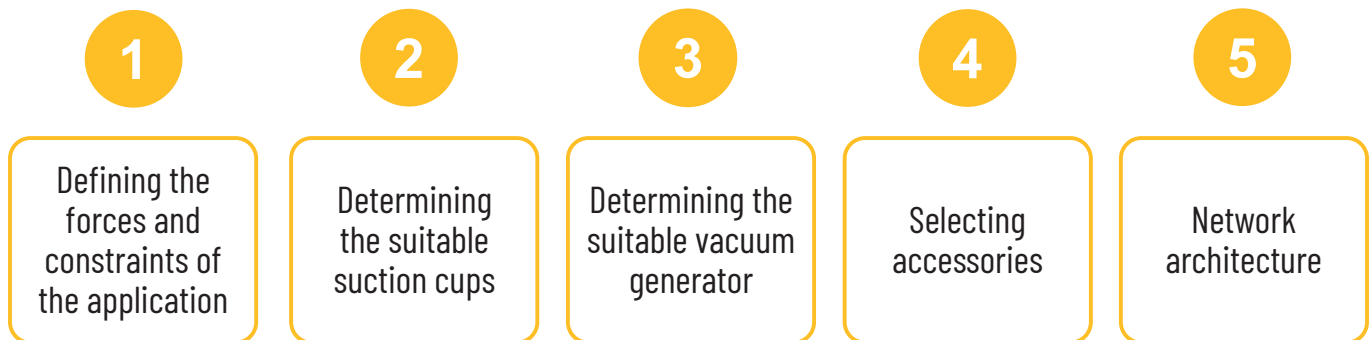

Checklist of the technical specifications to consider

SPECIFICATIONS VACUUM GENERATOR	
NEED OF ELECTRIC CONTROL	YES/NO
N.O or N.C VACUUM CONTROL	N.O/N.C
BLOW OFF CONTROL	YES/NO
MAXIMUM RESPONSE TIME	ms
REQUIRED VACUUM LEVEL	% ou mbar
NEEDED FLOW RATE	<u>Nl/mn</u>
MAXIMUM CONSUMPTION	<u>Nl/mn</u>
VACUUM SWITCH	YES/NO
DIGITAL DISPLAY	YES/NO
ANALOG / CONTACT OUTPUT	Ana / contact
LIFETIME	Millions cycles
PROTECTION	IP
AVAILABLE MINIMUM PRESSURE	bar
ELECTRICAL CONNECTION	M12 / M8 / CABLE
VACUUM NON RETURN VALVE	YES/NO
VACUUM REGULATION	YES/NO

SPECIFICATIONS APPLICATIONS	
AMBIANT PRESENCE OF OIL OR WATER	YES/NO
Min/Max AMBIANT TEMPERATURE	°C
Min/Max SURFACE TEMPERATURE	°C
COMPRESSED AIR QUALITY	ISO (see p22)
MAXIMUM WEIGHT TO HANDLE	Kg
ACCELERATION	m/s ² (ou G)
CYCLE TIMES	s
FOOD COMPATIBILITY	FDA / CE 1934
AGRESSIVE CLEANING	Chemical substance/dilution
MATERIAL POROSITY	<u>Nl/mn/suction cup</u>
SURFACE POROSITY	<u>Nl/mn/suction cup</u>
PRODUCT TO HANDLE	Type / <u>material</u>

SPECIFICATIONS VACUUM NETWORK and SUCTION CUPS	
DIRECTION OF THE SUCTION CUPS	Horizontal / vertical
Ø AND LENGTHS OF THE CA TUBES	mm
Ø AND LENGTHS OF THE VACUUM TUBES	mm
REQUIRED SUCTION CUP TYPE	Part n°
STROKE OF THE SUCTION CUP	mm
CONNECTION	type

FREQUENTLY ASKED QUESTIONS (FAQ)

Impossible to reach the vacuum threshold

- Check the quality of the vacuum network (airtight fittings and state of the suction cups)
- Check the supply pressure
- Check if the vacuum generator is correctly dimensioned to compensate porosity leakages

No signal from the vacuum switch

- Check the vacuum threshold settings

Impossible to activate the vacuum or the blow-off

- Check the wiring and the LEDs state
- Check power supply

The vacuum regulation is frequently activated

- Leakage on the vacuum network. You need to check each connection starting from the cups to vacuum generator blocking one after another.

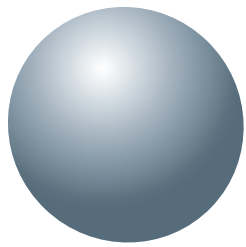

COVAL

vacuum managers

COVAL S.A.S
Siège Social
ZA Les Petits Champs
26120 Montélier
FRANCE

Tél. (+33) 04 75 59 91 91
Fax : + 33 (0)4 75 59 91 05