

COVAL

vacuum managers

GLOBAL CATALOG

vacuum
components



INTERACTIVE VERSION

ADVANCED VACUUM SOLUTIONS

www.coval.com

EN5

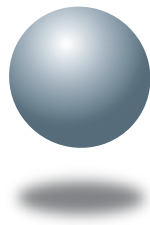

COVAL

vacuum managers





COVAL
vacuum managers

VACUUM MANAGERS

Welcome to the new COVAL catalog!

At COVAL, we set out to provide our clients and users with **vacuum handling** solutions that meet their goals in terms of profitability, productivity, quality, safety, and environmental conservation.

To achieve this, COVAL is rallying its efforts to predict, plan, innovate, and manufacture with one aim in mind: offering the right products and services at the right time.

In practical terms, this is what it takes:

- Impeccable knowledge of various industrial sectors.
- Being attentive and available to our clients' teams and users.
- The ability to adapt quickly to evolving needs.
- A rigorous approach to all of COVAL's efforts and endeavors.

To meet our commitments every day, at COVAL we have been developing an organization and a culture geared towards constant innovation, quality, and service for more than 35 years:

- Teams specialized by industry: food processing, aeronautics, robotics, plastic processing, packaging, and more.
- Strong in-house capacity for research and innovation complemented with external resources through public and private partnerships.
- Strong presence thanks to our sales team, foreign subsidiaries, and authorized dealers.

COVAL is the Vacuum Manager for each and every one of its clients.

We bring together all the skills and know-how to manage the vacuum handling of their parts, products, or packaging.

This catalog presents our products and services, illustrating COVAL's vision of innovation, with a focus on energy savings, communication, and ease of use, as well as compactness.

It is an introduction to discussions with our sales and technical teams about your projects.

The COVAL team

COVAL is a member of the **French Fab**, sharing with it the values of innovation, French manufacturing, digital transformation, and international development.



More
information



COVAL SERVICES

COVAL combines its products with efficient services to assist in defining your needs, selecting your solution, integrating your products, and optimizing your equipment.

► ALL COVAL PRODUCTS ONLINE

Just click to access our entire product range, which is regularly updated, and download any of our catalogs.

► 3D ONLINE LIBRARY

You have free access to 3D files of all our products in formats compatible with leading CAD software from our website at www.coval.com



You can use this fast, new, reliable service to make it easier to integrate our components directly into your designs.

► TECHNICAL PHONE SUPPORT

COVAL provides you technical support to answer all your questions regarding its products, solutions, and services: find a product or spare part, get advice on recommended use, request technical documentation, ask for technical information (how to avoid pressure losses, reduce noise level, save energy, etc.).

www.coval.com

► MOBILE APPLICATION

The **COVAL e-catalogue** application gives you access to all our products from anywhere, allowing you to perform the following actions for each product:



- Download 3D models.
- View the latest up-to-date technical data.
- Download and share technical data sheets.

► COVAL SOLUTIONS SERVICES

To adapt our products to your specific applications, both the COVAL engineering and design department and its development team are dedicated to providing solutions that meet your specifications.

vacuum
management



QUALITY AND INNOVATION

COVAL applies an ambitious quality and innovation policy to all its product ranges. Our quality relies on a comprehensive approach, which brings together client focus, staff training, and teamwork.

All these elements foster a favorable environment and culture for each collaborator to contribute to innovation.

This commitment has led to several awards and certifications that reward both the products and their industrial applications.

► BROAD INNOVATION NETWORK

At COVAL, we believe that openness to public research centers, universities, and technology clusters is the primary qualification for being able to offer our clients products that make them more competitive. These collaborations complement and strengthen the internal resources of our Research and Innovation Center.

To drive this strategic intent, the Innovation Manager's focus is to develop COVAL interactions with its environment in order to innovate in technical, human, and organizational fields.

► ISO 9001 CERTIFICATION: V2015

With this standard, COVAL seeks to achieve the following:

- Satisfy its clients' quality requirements.
- Meet applicable regulatory conditions.
- Improve client satisfaction.
- Constantly optimize performance to achieve these goals.



To do this, COVAL teams focus on clients and rally behind a process of ongoing improvement. Our primary goal is to build a lasting relationship with our clients.

► AN EXAMPLE OF INNOVATION: INTELLIGENCE AT THE HEART OF THE VACUUM PUMP

Vacuum pumps are used in a wide variety of automated systems, primarily to generate and control vacuum in suction cups to ensure the gripping of objects. They must be easily integrated into a process and communicate the information necessary to ensure proper production.

To meet the expectations of manufacturers and the demands of automated applications, COVAL offers a complete range of vacuum pumps to meet different needs: vacuum levels, suction rates, control types, communication technologies, and energy savings.

Communication needs vary depending on the industry and application, but more and more, an efficient and real time communication system allows for increased flexibility of the machine.

In addition, the simplification of wiring and configuration is a benefit for integrators, while expanding the possibilities of diagnosis and optimization.



ENERGY SAVINGS

COVAL is committed to making your vacuum handling system energy-efficient. Our goal is to optimize the overall performance of your equipment by operating on the following three principles:

- Analyzing the system to identify the potential for savings.
- Selecting the most appropriate solution.
- Including COVAL energy-saving technologies, such as ASR and ASC, in our products.

AIR Saving Regulator : AIR SAVING REGULATOR

➔ **40%** energy savings on average

The AIR SAVING REGULATOR (ASR) regulates the compressed air pressure to 3.5 bar in all circumstances to obtain a perfect mix of efficiency and consumption.

- No more unnecessary consumption of compressed air.
- No external regulator required, thus eliminating the risk of improper adjustment.

The following products feature this technology:

- LEM
- LEMP
- LEMAX
- LEMAX IO
- LEM+
- LEMAX+
- LEMCOM

AIR Saving Control : AIR SAVING CONTROL

➔ **90%** energy savings on average

AIR SAVING CONTROL (ASC) is an intelligent system that stops the consumption of compressed air as soon as the required level of vacuum is reached, thus avoiding any unnecessary consumption and contributing to savings on the equipment's operating costs.

The following products feature this technology:

- LEMAX
- LEMAX IO
- LEMAX+
- LEMCOM
- GVMAX HD

ENERGY SAVING APP

Measure the savings online that you can make with a COVAL vacuum handling solution.

The **ENERGY SAVING APP** allows you to measure the savings you can generate with COVAL vacuum pumps featuring the **ASC (Air Saving Control)** technology compared with conventional vacuum pumps.

This unique app in the world of vacuum technology is very intuitive to use. Once you've entered the equipment's main characteristics (gripping cycle time, number of cycles, run time, volume to be evacuated), the savings are displayed automatically in euros, air volume, and savings percentage. In most cases, it is quite significant since it peaks at 97% of energy saved, for example with the LEMAX.

It is, therefore, easy to realize that investing in a COVAL pump featuring ASC pays for itself, on average, after less than a year of use.

This COVAL exclusive strengthens our calling as your company's Vacuum Manager and our desire to contribute to improving the energy and production performance of your equipment.

You can access this software from the COVAL website:
<https://www.coval-international.com/company/our-technologies/>

Products concerned: ▪ LEMAX ▪ LEMAX IO ▪ LEMAX+ ▪ LEMCOM ▪ GVMAX HD.

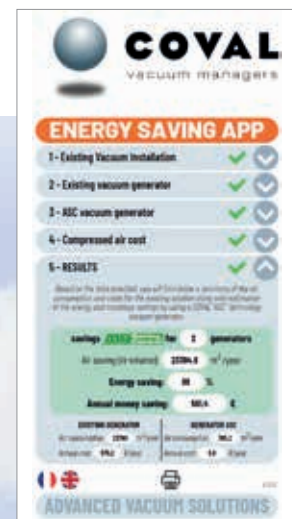



MADE IN EXCELLENCE

For more than 35 years, COVAL has been working every day on offering its clients outstanding products and services. This is not merely a goal, it's a daily commitment that drives each of our teams: sales, engineering and design, production, logistics, innovation, and management.

To foster this spirit of excellence, COVAL constantly invests in the following areas:

- ▶ **MODERNIZING ITS INDUSTRIAL EQUIPMENT** to improve quality and productivity.
- ▶ **TRAINING** to enable each and everyone to update their skills, become more versatile, and advance within the company.
- ▶ **OPEN INNOVATION** to let our clients be the first to benefit from the most advanced technology.
- ▶ **RIGOROUS ORGANIZATION** to guarantee our clients obtain the quality, responsiveness, and flexibility they expect.



MADE IN FRANCE

COVAL is established at the heart of the Auvergne-Rhône-Alpes region, a particularly powerful economic area in terms of research and industrial production.

In its immediate environment, COVAL can rely on the following assets:

- France's leading network of industrial subcontracting.
- 7 business clusters directly linked to its activity: mechatronics, automation, mechanics, food processing, and more.
- 5 universities whose curricula focus on industrial technology.
- Leading network of high-speed trains in Europe.

These favorable conditions all contribute to the development of COVAL's products and services and clearly make **Made in France** an obvious choice.



YOU DESERVE MUCH MORE THAN JUST VACUUM

Being able to benefit from high-performance products for the vacuum handling of your workpieces, products, and packages is your main requirement, but that's not enough by itself: you want solutions that are comprehensive, performing, and perfectly suited for your industry.

In order to bring you more than just vacuum, we are committed to a comprehensive development approach:

► **SOLUTIONS** that take into account all your concerns:

- The constraints of your process.
- The specific features of your products.
- The safety of operators.
- The energy performance of your equipment.

► **PRODUCTS** that you can trust:

- Reduced space requirements for better integration.
- Continuously improved performance.
- Reduced energy consumption.
- Easier communication and interaction with the machine.

► **KNOW-HOW** that meets your needs:

- A thorough analysis.
- Customized advice.
- Capacity for engineering and innovation.
- High-quality manufacturing and service.
- Ongoing follow-up throughout the entire life cycle of our products.

► **TEAMS** that specialize in **YOUR INDUSTRY**:

At COVAL, technical and sales teams are dedicated to strategic industry sectors: packaging, food processing, plastics, automotive, aeronautics, and robotics.

The experience they've acquired with major brands and manufacturers allows them to provide quick and efficient answers.

Our goal is to be present wherever vacuum handling and automation is useful for the performance of the business.

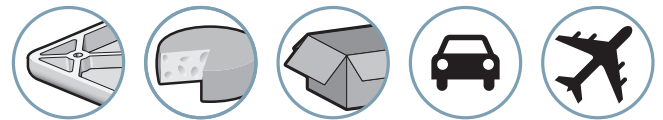



COVAL
vacuum managers

COVAL ALL ALONG THE LINE

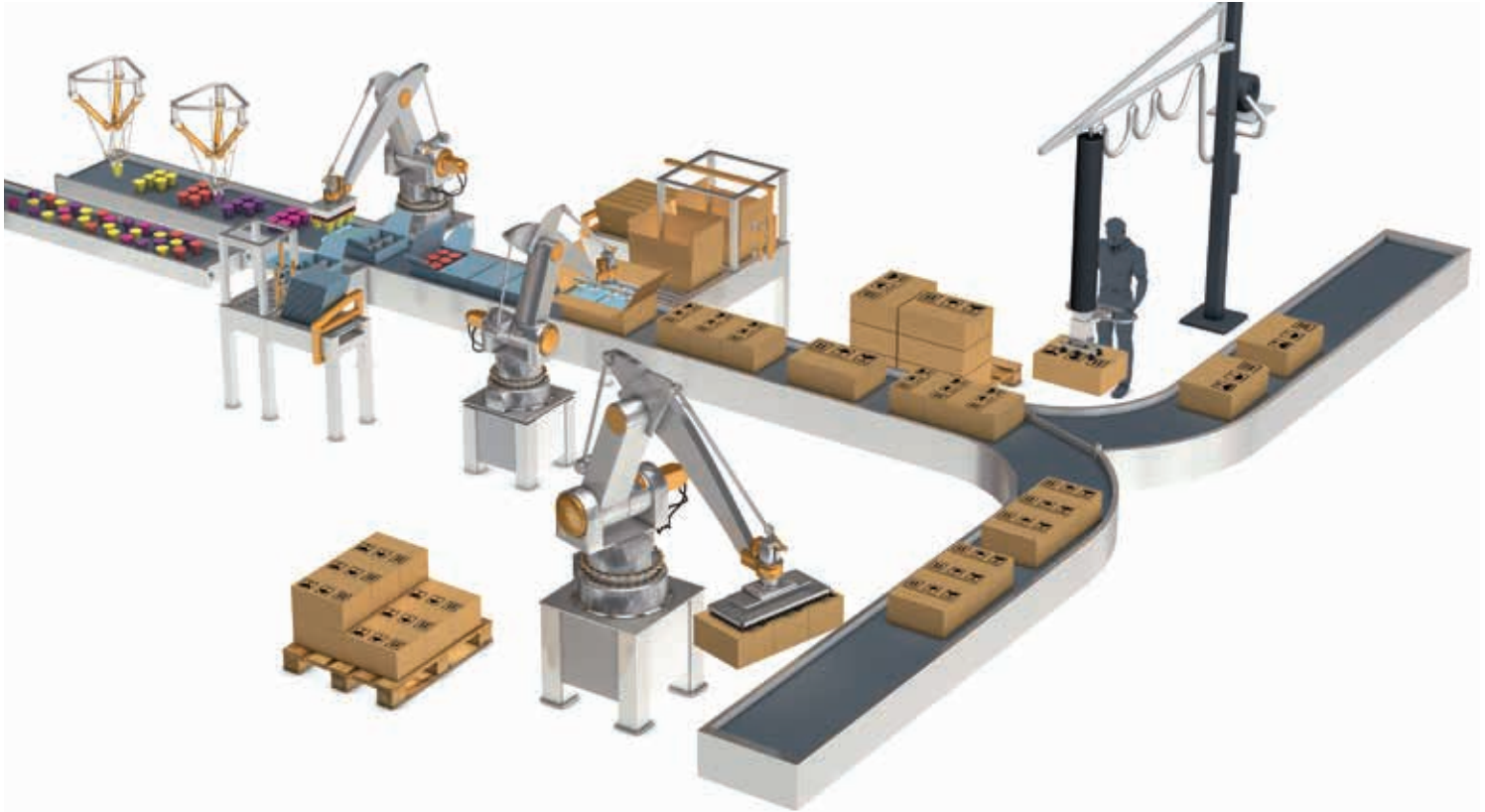

ADVANCED VACUUM SOLUTIONS

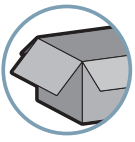

Industry Solutions: **PACKAGING**



Packaging plays an important role in industrial production. Vacuum applications in this field range from grasping small bags to handling large-sized cardboard boxes.

Their extremely various size, shapes, weights, and materials are a result of the many functions they need to fulfill: hold, transport, and store products, but also inform, promote, and facilitate use, etc.

Regardless of the type of packaging, the handling constraints are always the same:

- Safety of goods and operators.
- Handling throughput.
- Versatility.
- Energy savings.

More information

COVAL All Along the Line

► SUCTION CUPS

Suction cups meet a wide variety of specifications thanks to the large choice of shapes, diameters, and materials. COVAL offers a complete line of fastening fittings that are suitable for suction cups and compatible with all types of applications.

- Flat and extra-flat suction cups.
- 1,5, 2,5, 4,5 and 5.5 bellows.
- Oblong suction cups.
- High-performance suction cups.

→ See chapters 2 and 3.



► VACUUM PUMPS

COVAL vacuum pumps all have compactness, embedded intelligence, and low energy consumption in common.

- Micro-ejectors.
- Modular vacuum pumps.
- Smart vacuum pumps.

→ See chapters 6 to 9.



► VACUUM GRIPPERS

Vacuum grippers are used to grip several products (flow packs, tins, cans, etc.) or packages (palletization) at once.

- **MVG**: fully configurable vacuum grippers.
- **CVGL**: vacuum grippers with many possible combinations.
- **CVGC**: carbon vacuum grippers for collaborative robots

→ See chapter 13.





More
information



Being located in France, the world's second largest exporter of food, COVAL enjoys an exclusive relationship with the food processing industry.

Whether this involves handling raw, prepared, or packaged goods, COVAL has continually developed and adapted its products to the food processing industry needs:

- Making production lines more versatile.
- Producing within a safe food environment.
- Increasing productivity while maintaining a high level of quality.
- Reducing production and maintenance costs.

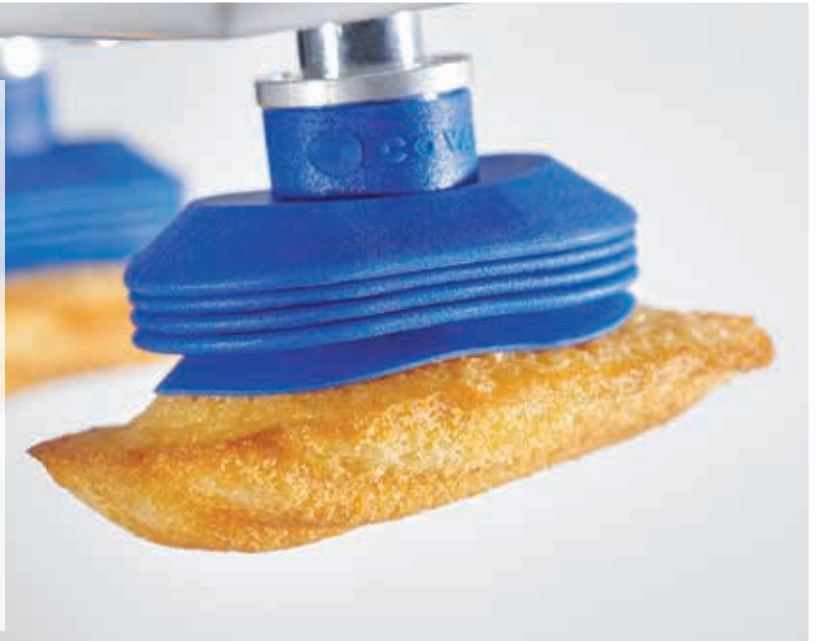

Suction Cups with a Firm Grip on Your Products

► SILICONE SUCTION CUPS

They are compatible with FDA food standards (FDA 21 CFR 177.2600.) and in conformity with European directives EU 1935/2004 and available in a wide variety of models to adapt perfectly to your products.

- From 1 mm to 88 mm in diameter.
- Round and oblong shapes.
- Flat, 1.5 and 2.5 bellows.
- **Metal-detectable version available upon request.**

→ See chapter 2.



► VACUUM PUMPS

COVAL vacuum pumps all have compactness, embedded intelligence, and low energy consumption in common.

- **LEM and LEM+ series** for handling all porous or airtight parts.
- **LEMAX, LEMAX IO and LEMAX+ series** for handling all airtight or slightly porous parts.
- **LEMCOM series:** vacuum pumps with fieldbus communication.
- **CMS HD series:** Heavy Duty Multi-stage Vacuum Pumps.

→ See chapter 8.



► SPECIAL SUCTION CUPS

- FlowPack Suction Cups: **FPC** series.
- **MVP Series, Packaging Suction Cup**
- Suction cups for bakery applications: **VSD, VSE, and VSP** series.
- Suction cups for egg-handling: **VSO** series.

→ See chapter 3.



► VACUUM GRIPPERS

Vacuum grippers are used to grip several products (flow packs, tins, cans, etc.) or packages (palletization) at once.

- **MVG:** fully configurable vacuum grippers.
- **CVGL:** vacuum grippers with many possible combinations.
- **CVGC:** carbon vacuum grippers for collaborative robots

→ See chapter 13.





Industry Solutions: **AUTOMOTIVE INDUSTRY**



COVAL has been delivering simple, flexible, modular, compact, and energy-efficient vacuum handling and automation solutions to car manufacturers for more than 35 years:

- High-throughput handling of workpieces on stamping press lines.
- Workpiece transport and clamping for gluing and welding at welding stations.
- Handling of windshields or sheet steel parts for assembly.

Integration, Performance and Energy Savings

► C SERIES AND CTC SERIES HIGH-PERFORMANCE SUCTION CUPS

These suction cups are available in a wide range of sizes and shapes and have been developed to meet the constraints of the automotive industry:

- Optimal placement of oily steel sheets: anti-slip cleats.
- Preservation of workpieces: polyamide fittings.
- Airtight fastening: o-ring.

Versions made of SITON® are available for handling hot workpieces (plastic workpieces, hot stamping).

CTC Series bell-type suction cups:

- Excellent adaptation to convex surfaces and angular shapes
- Excellent resistance to wear and oil thanks to thermoplastic polyurethane (TPU)

→ See chapter 2.



► HEAVY DUTY COMMUNICATING VACUUM PUMPS, GVMAX HD SERIE

- Optimized robot equipment: ultra-compact and lightweight.
- Reduced gripping times: powerful suction flow rate.
- Up to 90% compressed air savings: ASC technology.
- Maintenance free: non-clogging.
- IO-Link communications interface
- Clear and efficient HMI
- Straightforward setup and diagnostics made possible by NFC technology and COVAL Vacuum Manager mobile application.

→ See chapter 8.



AIR Saving Control

SMART SWAP

IO-Link
NFC



Industry Solutions: **AERONAUTICS**

In a growing industry, the ability to reduce production times while preserving a high level of quality is essential. COVAL has worked on the following specific solutions with major manufacturers:

- Gripping parts on laser-trimming machines.
- Referencing and holding aircraft parts during drilling, sanding, riveting, etc.
- Integrating vacuum components in demonstration tools.
- Gripping aircraft parts made of various materials: steel, stainless steel, aluminum, and composite materials.



More information



Dedicated Solutions for your Industry

► **C SERIES HIGH-PERFORMANCE SUCTION CUPS AND CTC SERIES**

- Gripping thin workpieces without deformation.
- Handling or holding in vertical position.
- Optimal positioning and holding: anti-slip cleats.

→ See chapter 2.



► **LEMAY, LEMAY IO, LEMAY+, LEMCOM AND GVMAX HD SERIES VACUUM PUMPS**

- Optimized robot equipment: ultra-compact and lightweight.
- Reduced gripping times: powerful suction flow rate.
- Up to 90% compressed air savings: ASR technology.
- Maintenance free: non-clogging.
- PROFINET or EtherNet/IP fieldbus for the LEMCOM series.
- IO-Link communications interface for the LEMAY IO and GVMAX HD series.

→ See chapter 8.



► **VPSC MARK-FREE ULTRA-FLAT SUCTION CUPS**

- Gripping raw composite materials.
- No material migration.
- Non-marking on composite parts.

→ See page 3/35.



► **CONTROL BOX WITH INTEGRATION FUNCTIONS**

- Integrated pneumatic or electric vacuum pumps.
- Control and monitoring panel allowing you to manually or automatically select the gripping areas on a structure.
- Indicator light for visual alarm.
- Vacuum sequencing to assist with placement of a curved panel.

→ Upon request.





Industry Solutions: **PLASTICS**

Hidden behind the generic term “plastics”, you will find materials that are very different in their composition, manufacturing, appearance, and applications.

For more than 35 years, COVAL has been developing vacuum handling solutions that are tailored to the constant technological developments of the processes and materials.

Our vacuum pumps and suction cups are able to handle plastics and composites for industries such as aeronautics, cosmetics, electronics/connectors, health, and transportation.

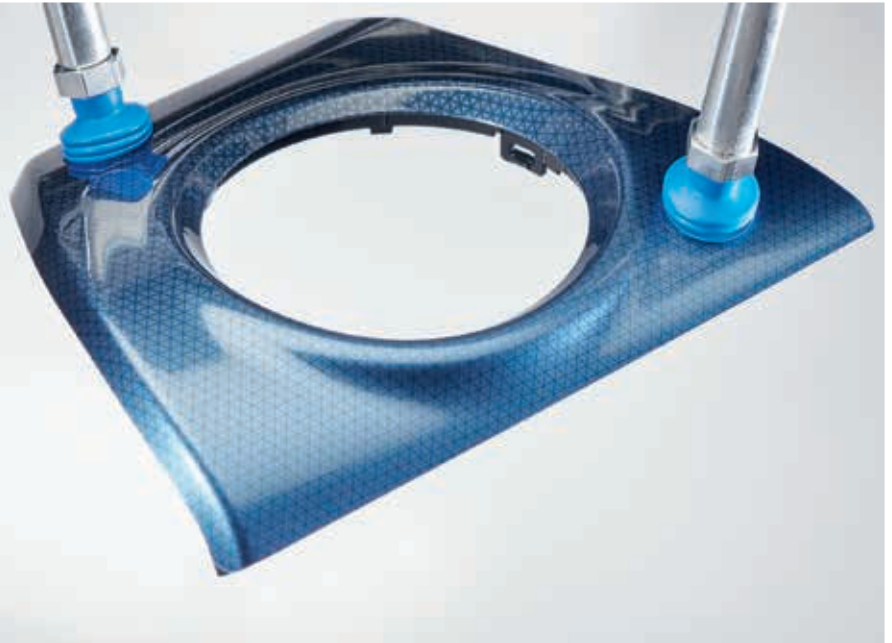

More information



SITON® material, A COVAL Exclusive

► SITON® MATERIAL SUCTION CUPS

SITON®, developed and manufactured exclusively by COVAL, is a non-marking silicone-free material specially designed for handling hot plastic parts from injection molds.

Advantages of SITON® material

- Non-marking: clear, silicone-free compound.
- Withstands continuous temperatures of 130°C (266°F) up to 160°C (320°F) at peak.
- Excellent abrasion resistance.

Many suction cup models are available in SITON® 60 Shore A (STN) in this catalog.

For greater flexibility, models in SITON® 50 Shore A (STN5) are available upon request.

→ See chapter 2.



Intelligent Vacuum Pumps

► LEMAX, LEMAX IO, LEMAX+, LEMCOM AND GVMAX HD SERIES

Vacuum pumps with ASC are used for handling all airtight or slightly porous plastic parts.

- Ultra-compact and lightweight.
- More than 90% energy savings thanks to ASC technology.
- Silent operation.
- Auto-adjustment corresponding to the material handled.
- Maintenance free: non-clogging.
- PROFINET or EtherNet/IP fieldbus for the LEMCOM series.
- IO-Link communications interface for the LEMAX IO and GVMAX HD series.

→ See chapter 8.

AR Saving Control



IO-Link NFC)))

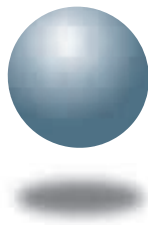

COVAL
vacuum managers



NEW PRODUCTS

Always in touch with the latest market developments, COVAL is driven by constant innovation and regularly introduces new products and solutions that meet specific vacuum handling needs.



IO-Link

► **LEMAX IO Series**
Mini Vacuum Pumps with
Communication IO-Link



IO-Link
NFC

► **CVGL Series**
Communicating Compact and
Light Vacuum Grippers



IO-Link NFC

► **GVMAX HD Series**
Heavy Duty Communicating
Vacuum Pumps



IO-Link
NFC

► **MVG Series**
Communicating Modular
Vacuum Grippers



IO-Link NFC

► **CMS HD Series**
Heavy Duty Communicating
Multi-stage Vacuum Pumps

These new products are already available today. Feel free to ask your COVAL preferred contact for more information.

Discover COVAL's intelligent vacuum pump range on the following pages



COVAL's Family of Intelligent Vacuum Pumps

Vacuum pumps are used in a wide variety of automated systems, primarily to generate and control vacuum in suction cups to ensure the gripping of objects. They must be easily integrated into a process and communicate the information necessary to ensure proper production.



To meet the expectations of manufacturers and the demands of automated applications, COVAL offers a complete range of vacuum pumps to meet different needs: vacuum levels, suction rates, control types, communication technologies, and energy savings.

Communication needs vary depending on the industry and application, but more and more, an efficient and real time communication system allows for increased flexibility of the machine.

In addition, the simplification of wiring and configuration is a benefit for integrators, while expanding the possibilities of diagnosis and optimization.

Key points of intelligent vacuum pumps



Functions	Model	LEMP	LEM	LEMAX	LEMAX IO	LEMCOM	LEM+	LEMAX+	GVMAX HD	CMS HD
Recommended for porous products		■	■			■	■			■
Recommended for airtight products				■	■	■		■	■	
Suction flow rate from 29 to 92 NI/min		■	■	■	■	■				
Suction flow rate from 125 to 275 NI/min							■	■	■	
Suction flow rate from 700 to 1600 NI/min										■
Maximum vacuum level: 60%		■	■			■	■			
Maximum vacuum level: 80 or 85%		■	■	■	■	■	■	■	■	■
Vacuum control			■	■	■	■	■	■	■	■
Blow-off control			■	■	■	■	■	■	■	■
Integrated pressure regulator (ASR)		■	■	■	■	■	■	■		
Powerful blow-off							□	□	□	
Electronic vacuum switch with display		□	□	■			□	■	■	□
Electronic vacuum switch					■	■				
Pressure sensor									■	□
Vacuum check-valve				■	■	■		■	■	
Automatic vacuum regulation (ASC)				■	■	■		■	■	
M8 connections		□	■	■	■	■				
M12 connections							■	■	■	■
Island Assembly Available		■	■	■	■	■			■	
SMART SWAP Quick-mounting system									■	
Field bus EtherNet/IP™ / PROFINET						■				
IO-Link					■				■	□
NFC									■	□

■: Standard or integrated □: Option

Energy Savings

COVAL is committed to making your vacuum handling system energy-efficient. Our goal is to optimize the overall performance of your equipment by operating on the following three principles:

- Analyzing the system to identify the potential for savings.
- Selecting the most appropriate solution.
- Including COVAL energy-saving technologies, such as ASR and ASC, in our products.



ASR (Air Saving Regulator)

A "venturi pressure regulator" that guarantees optimized operation at 3.5 bar.

Ideal for gripping of porous products or rough surfaces.

Advantage: Up to 40 % energy savings.



ASC (Air Saving Control)

A vacuum regulation system that auto-adjusts to the product being handled.

Ideal for gripping airtight products.

Advantage: Up to 90 % energy savings.

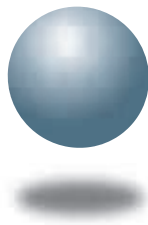

COVAL

vacuum managers

A vast ecosystem of vacuum pumps to meet all needs.

From simple control to communication technologies designed for the industry of the future...

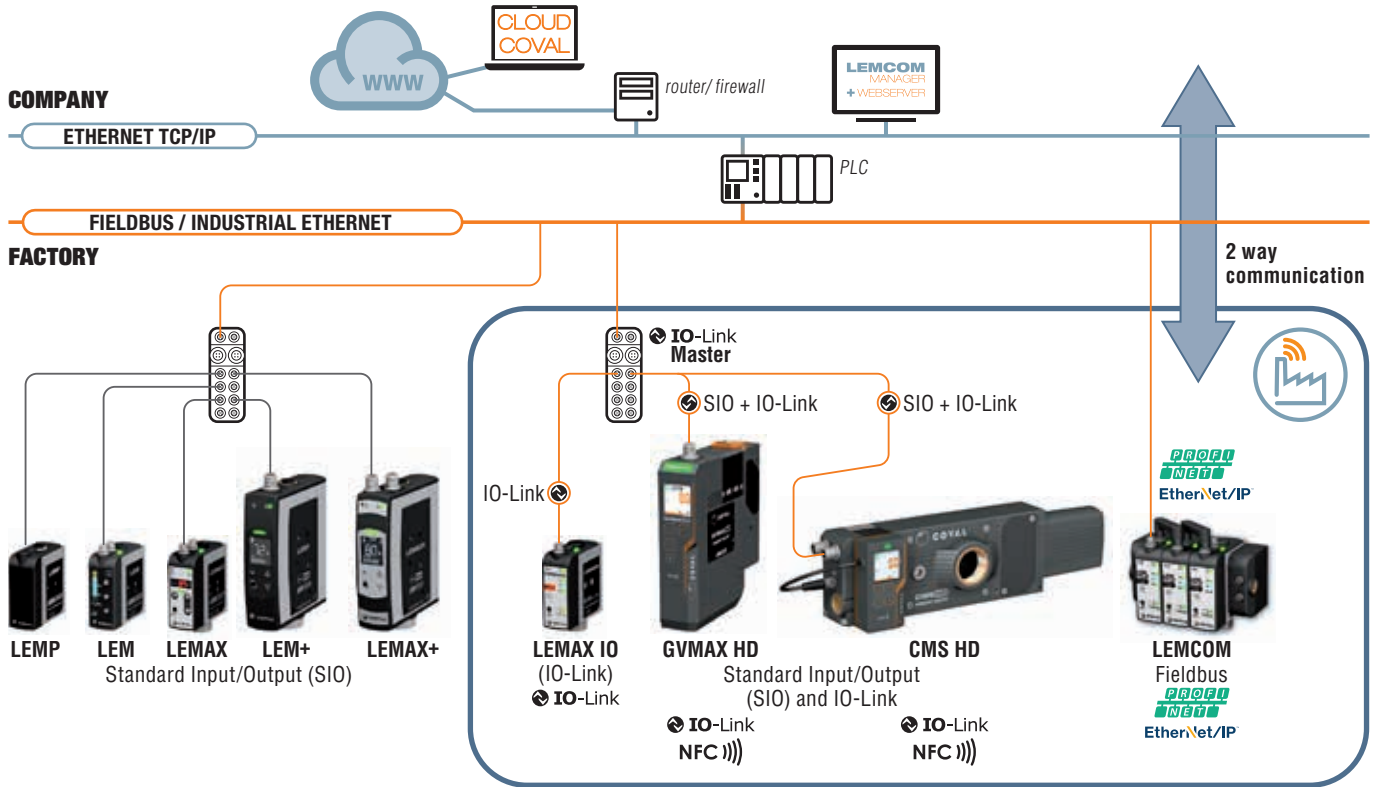

Key points of communication technology

Communication interface with the machine

Industrial Ethernet

- Supported buses: PROFINET, EtherNet/IP™.
- Direct connection to the machine's ethernet network.
- 2 cables for power and control of 1 to 16 vacuum pumps.



IO-Link

- Compatible with all fieldbus and industrial ethernet networks (via IO-Link master).
- 3-wire connection.
- Easy maintenance thanks to the storage of parameters in the IO-Link master.



User communication interface

LEMCOM Manager

- PC control software, configuration, and diagnostic software for the LEMCOM series, dedicated to "vacuum applications".

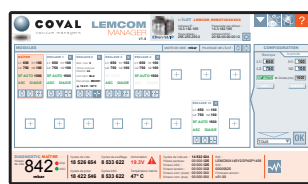

WEB Server

- Embedded on the master modules of the LEMCOM series.
- Integrated into the commercial IO-Link master for the LEMAX IO/ GVMAX HD.
- Direct access to control, configuration, and diagnostic functions.

Vacuum Manager App (NFC)

- Available on iOS and Android.
- Configuration and diagnosis of the GVMAX HD and CMS HD series.
- Uploading of operating data to the COVAL cloud.



High resolution display

- LCD color display on GVMAX HD and CMS HD series.



COVAL
vacuum managers

A TECHNOLOGICAL PARTNER ON A GLOBAL SCALE

Every year, we keep developing our network of partners (subsidiaries, distributors and independent agents) to assist our clients in their quest for local and international markets.

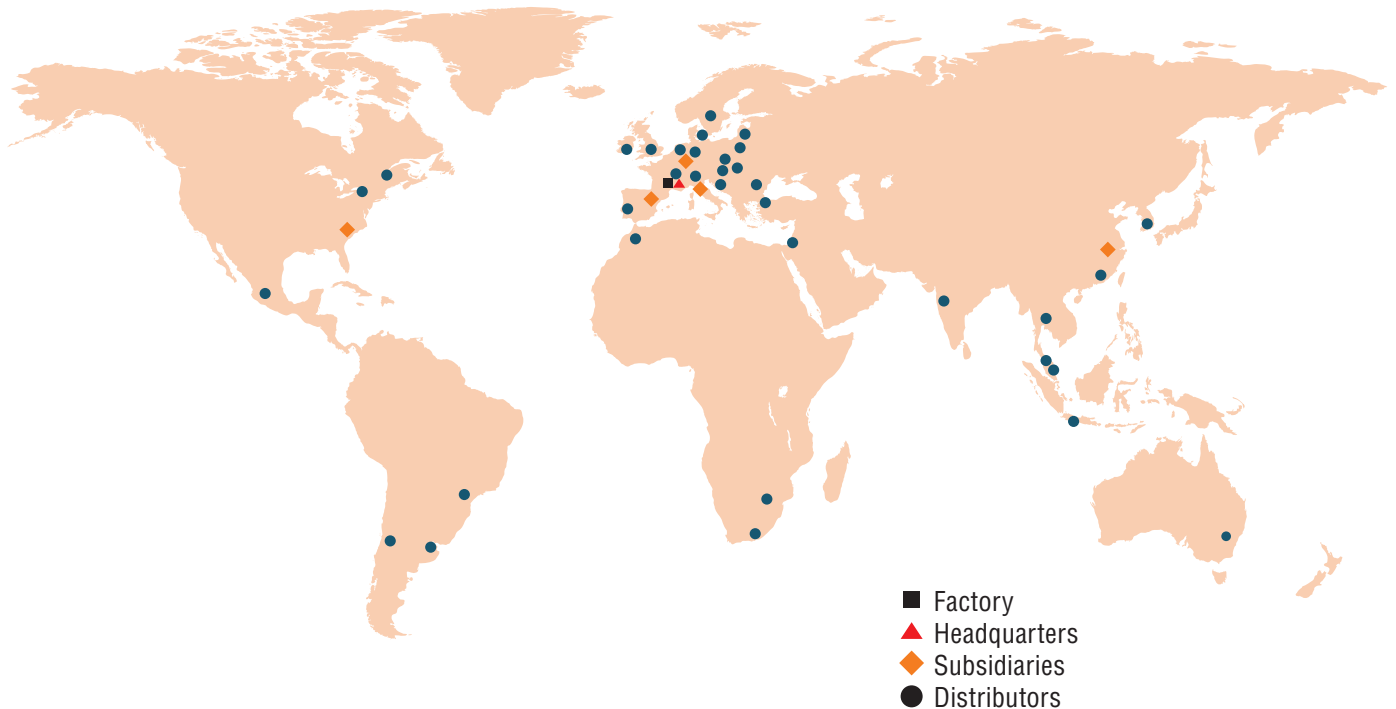

► **HEADQUARTERS** based in **FRANCE**

Since its creation in 1986, COVAL S.A.S. is established in Montélier in southern France.



► **5 SALES SUBSIDIARIES**



COVAL Inc.



COVAL Iberica



COVAL Germany



COVAL Italia



COVAL China

► A broad network:

- + 25 authorized **DISTRIBUTORS** in **FRANCE**
- + 40 authorized **DISTRIBUTORS** outside **FRANCE**

► Visit the following section on our **WEBSITE:**
Contact – Sales network,
to view the latest **UP-TO-DATE LIST**



ADVANCED VACUUM SOLUTIONS

Table of Contents

General Points About Suction Cups	Chapter 1
Standard Suction Cups	Chapter 2
Special Purpose Suction Cups	Chapter 3
Suction Cup Accessories	Chapter 4
Vacuum Pumps Overview	Chapter 5
Micro Ejectors / Vacuum Cartridges	Chapter 6
Vacuum Pumps without control	Chapter 7
Intelligent Vacuum Pumps	Chapter 8
High Flow Vacuum Generators	Chapter 9
Electric vacuum pumps and Blowers	Chapter 10
Vacuum Pump Accessories	Chapter 11
Vacuum Switches	Chapter 12
Gripping Solutions	Chapter 13
Peripheral Devices	Chapter 14
Alphabetical Index	

Table of Contents















INTRODUCTION: Guide to Vacuum Handling

VII to XII

SUCTION CUPS

Chapter 1 General Points About Suction Cups

Chapter 2 Standard Suction Cups

	VP Flat suction cups Ø 8 to 75 mm	2/3		VSAJ Suction cups with 1.5 bellows Ø 15 to 30 mm	2/43
	VPG Extra-flat suction cups Ø 2 to 200 mm	2/9		VS Suction cups with 2.5 bellows Ø 5 to 88 mm	2/47
	VPU Flat suction cups Ø 6 à 50 mm	2/17		VSG Suction cups with 2.5 bellows Ø 5 and 7 mm	2/53
	VPF Flat suction cups with cleats Ø 15 to 50 mm	2/20		VSD Long stroke suction cups	2/55
	VPO Oblong flat suction cups	2/23		C High-performance suction cups	2/59
	VSA Suction cups with 1.5 bellows Ø 5 to 78 mm	2/27		CTC High-Performance Bell-type Suction Cups	2/63
	VSAB Suction cups with 1.5 bellows Ø 5 to 50 mm	2/33		VSA-VS BM VSA-VS BM-SIF VSBM	
	VSAG Suction cups with 1.5 bellows Ø 10 to 150 mm	2/37		Suction Cups with Foam Ring Seals	2/65

Chapter 3 Special Purpose Suction Cups





























	FPC - FPCX FlowPack Suction Cups	3/4		VSAOF Oblong Suction Cup for Cheese	3/14
	MVS Soft Suction Cups for High Speed Applications	3/7		VSD, VSE, VSP Suction cups for bakery applications	3/15
	MVP Suction Cups with 4.5 Bellows	3/10		VSO Suction cups for egg-handling	3/17
	VSAF Suction Cup for Cheese	3/13		VSBO, VSBO+ VSBO LM/BM Suction cups for bottle handling	3/18

Table of Contents

	VBO Suction cup for bottle handling via the punt	3/27		VPAG Curved suction cups	3/34
	VPBO Coupler plates for gripping bottles by the punt	3/28		VPSC Ultra-flat, Non-Marking Suction Cups	3/35
	VPA Suction cups for paper applications	3/29		VPYR Radial ball-joint suction cups	3/36
	VPAL / VSAPL Suction cups for labels	3/31		SPL Heavy load suction cups	3/37
	VPR Suction cups for mailing applications	3/33		STEEL Steel suction cups	3/38

Chapter 4 Suction Cup Accessories

	TS11 Spring systems	4/3		Miscellaneous gripping	4/9
	TS Spring systems TS1 – TS2 – TS3	4/4		Flow Control Nozzles	4/10
	TS Spring systems TS4 - TS5	4/5		PMG2 Mechanical feelers	4/11
	RSC Systems with 4 compensated springs	4/5		IMU Axial ball-joints	4/12
	TSOP - TSOG Anti-rotation spring systems	4/6		CSP Piloted Safety Valves	4/13
	L Extensions	4/8		BM Foam strips	4/14





VACUUM PUMPS

Chapter 5 Vacuum Pumps Overview





General points	5/2	COVAL's Family of Intelligent Vacuum Pumps	5/6
Choosing a vacuum pump	5/3	Vacuum pump range	5/8
Comparison of vacuum pumps and air amplifiers	5/4	Evacuation time and weight of vacuum pumps	5/11

Table of Contents















Chapter 6 Micro Ejectors / Vacuum Cartridges

	VR Heavy-duty in-line ejectors	6/2		CVPC Controlled Vacuum Cartridges	6/12
	GVR Heavy-duty in-line ejectors	6/6		CBP Pilot Control Cartridge	6/16
	CVP Vacuum Cartridges	6/8			

Chapter 7 Vacuum Pumps without control

	GVP Vacuum Pumps	7/2		GVEC «Easy Clean» Vacuum Pumps	7/11
	GEMP Simple Vacuum Pumps with "ASR" (Air Saving Regulator)	7/8		LEMP Mini Vacuum Pumps without control with ASR (Air Saving Regulator)	7/14

Chapter 8 Intelligent Vacuum Pumps

	LEM Integrated Mini Vacuum Pumps with ASR (Air Saving Regulator)	8/3		LEM+ Compact High Flow Vacuum Pumps with ASR (Air Saving Regulator)	8/39
	LEMAX Integrated Mini Vacuum Pumps with ASC (Air Saving Control)	8/11		LEMAX+ Compact High Flow Vacuum Pumps with ASC (Air Saving Control)	8/45
	LEMAX IO  IO-Link Mini Vacuum Pumps with Communication IO-Link	8/19		GVMAX HD  NFC  IO-Link Heavy Duty Communicating Vacuum Pumps	8/51
	LEMCOM   EtherNet/IP Mini Vacuum Pumps Communicating via Industrial Field Bus	8/27		CMS HD  NFC  IO-Link Heavy Duty Multi-stage Vacuum Pumps	8/65

Chapter 9 High Flow Vacuum Generators



	M-C Air amplifiers	9/2		TVM Pipes for air amplifiers	9/6
	MD Air amplifiers	9/5			

Table of Contents

Chapter 10 Electric vacuum pumps and Blowers



PVS

Dry vane vacuum pumps

10/2



TCL

Side-channel Blowers, single-stage and two-stage

10/6

Chapter 11 Vacuum Pump Accessories



QR

Diffuser-type Silencers

11/3



FVL68

In-line Vacuum Filter

11/9



MS

Blow-off Devices

11/4



FSLI

Liquid Separator Vacuum Filters

11/10



FVI

Vacuum Filters

11/5



SIL GV

Diffuser-type Silencers

11/11



FVUM, FVUG

Vacuum Filters

11/7



SIL K--C

Through Type Silencers

11/11

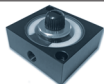

FVG

Mini Vacuum Filters

11/8



CD, CC

Screw-type Electrical Connectors

11/12



FVL12

In-line Filter

11/9

Chapter 12 Vacuum Switch Range



PSK

Vacuum Switch

12/3



PSE 100 E

Electric Vacuum Switch

12/9



PSA 100 C

Electronic Vacuum Switch With Display

12/4



PSE 100 P

Pneumatic Vacuum Switch

12/10



PSD 100

Vacuum Switch With 3-colour Display

12/5



PSE 100 PK

Pneumatic Vacuum Switch

12/11



PSP 100 CX

Electronic Vacuum Switch

12/7



VAF 111

Needle Vacuum Gauge

12/12

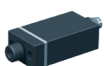

PSP 100 ANA





Electronic Vacuum Switch Analog Output

12/8

Table of Contents









VACUUM GRIPPERS / GRIPPING SOLUTIONS

Chapter 13 Gripping Solutions

	CVGC Carbon Vacuum Grippers for Collaborative Robots	13/2		MVG Modular Vacuum Grippers	13/24
	CVGL Compact and Light Vacuum Grippers	13/6		CSGS Bags/sacks Gripping System	13/42

ACCESSORIES

Chapter 14 Peripheral Devices

	VRU Vacuum Rotary Union	14/2		RVM, RVF, RVT - TVR - COV Fittings, Vacuum Tubes, Collars	14/6
	VRS Vacuum Rotary Connection	14/3		REV 38 Vacuum Regulator	14/7
	NVS, NVR, NVA Vacuum Feeders	14/4		AG Vacuum Valves, 3 Channels	14/8
	RDV, RCOV, Y Screwed Vacuum Fittings With O-ring	14/5		PA Angular Jaw Clamps	14/10

Alphabetical Index

I to III

Vacuum Handling Guide

Vacuum Applications and Measurements	p. VIII
Suction Cup Performance	p. IX
Vacuum Generation Technologies	p. X and XI
The Process of Defining an Installation	p. XII

Vacuum Handling Guide

Vacuum Applications and Measurements

VACUUM HANDLING DEVELOPMENT

Industrial vacuum applied to suction cups is an efficient method for handling objects and materials.

This technique was developed to meet automation needs in the industry with applications in parts assembly, finishing, testing, transfer, packaging, etc....

It is designed particularly for the automobile, wood and plastics industries, as well as all object transformation activities: food, electricals, furniture, etc.

Vacuum handling has become a key production technology, and this document will detail the rules, procedures and components involved.

MEASURING VACUUM LEVEL

Scientists use absolute pressure, with a scale that starts at perfect vacuum, with atmospheric pressure measuring roughly 1 bar.

For industrial applications, relative pressure is preferred because it marks a clear distinction between vacuum (negative pressure) and positive pressure.

In gripping applications, vacuum is only effective by its difference compared with atmospheric pressure. However, atmospheric pressure varies slightly depending on the altitude of the application site. This is why it is more practical to express vacuum level as a percentage of the atmospheric pressure.

The scale shown on the right illustrates the relationship between pressures expressed in bar and mbar and the vacuum level shown as a percentage of the atmospheric pressure. This relationship is accurate for use at an altitude of 100m. This is the measurement that we will use when discussing suction cups, since this is the most common altitude of industrial sites

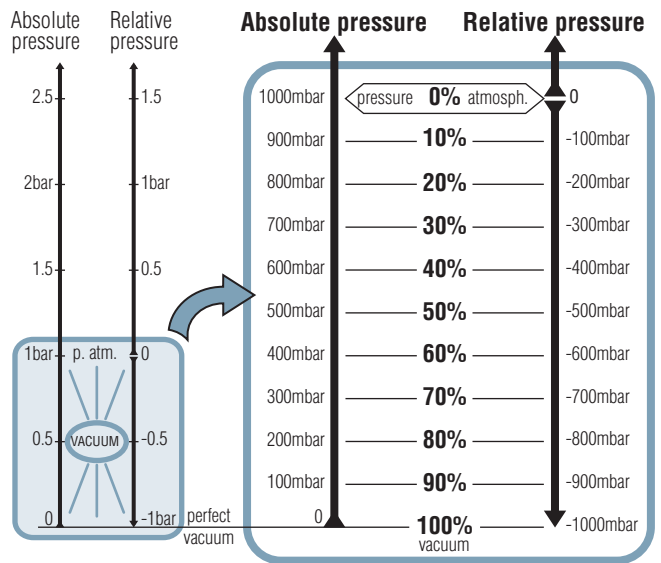

VACUUM UNITS CONVERSION

Relative vacuum

%	bar	mbar	Torr (mmHg)	inHg	kPa
0%	0	0	0	0	0
10%	-0.101	-101	-76	-2.98	-10.1
20%	-0.203	-203	-152	-5.99	-20.3
30%	-0.304	-304	-228	-8.97	-30.4
40%	-0.405	-405	-304	-11.96	-40.5
50%	-0.507	-507	-380	-14.97	-50.7
60%	-0.608	-608	-456	-17.95	-60.8
70%	-0.709	-709	-532	-20.93	-70.9
80%	-0.811	-811	-608	-23.94	-81.1
90%	-0.912	-912	-684	-26.93	-91.2
100%	-1.013	-1013	-760	-29.91	-101.3

RECOMMENDED VACUUM LEVELS

Gripping provides a level of effort that is proportional to the level of the vacuum that generates it (see curves below). For the most efficient operation, a maximum vacuum level is recommended. However, the curves also show that a high level of vacuum:

- has a high energy cost
- takes a long time to establish

This is why the vacuum levels used should be limited, from 30% when a high flow of vacuum needs to be maintained, to 80% in an airtight circuit (no flow required to maintain the vacuum).

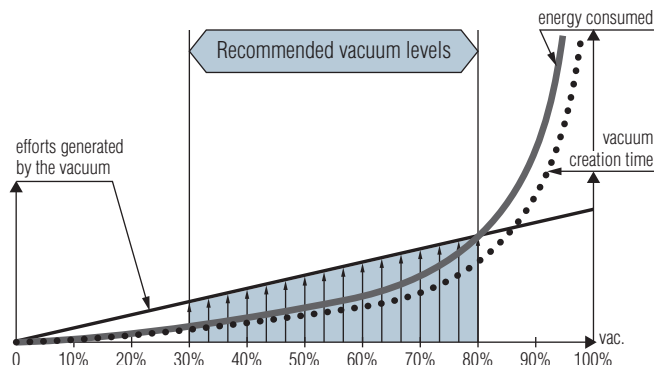

Vacuum Handling Guide

Suction Cup Performance

VACUUM HANDLING PHASES

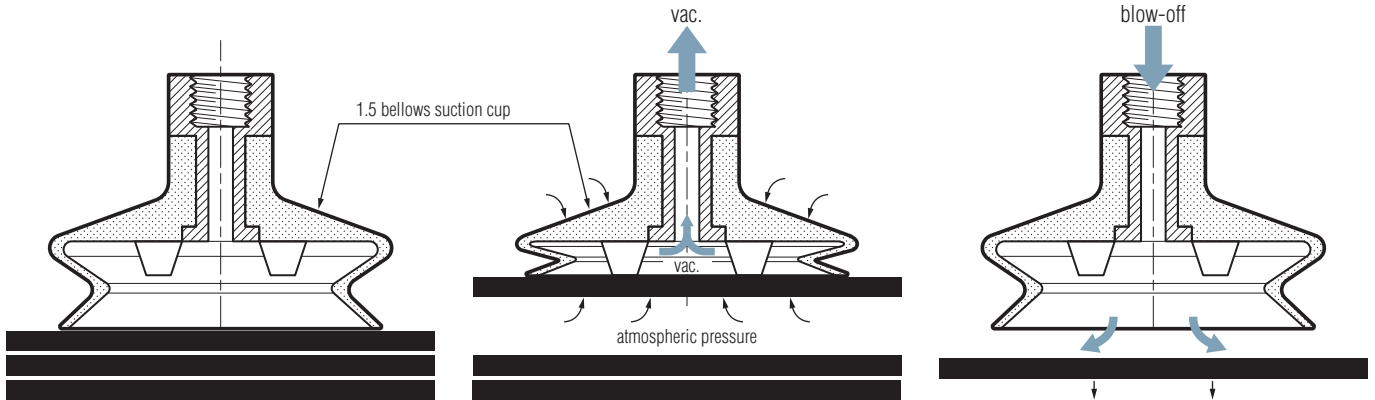

1- Approach

For shock-free contact with the surface to be gripped, and to conform to its shape, the suction cup in this instance has 1.5 bellows.

Chapter 2 outlines a choice of suction cups and fittings to facilitate this phase.

2- Gripping

Vacuum is then applied to the suction cup, which lifts the object pushed by atmospheric pressure.

The suction cup and object then remain bound together throughout the entire process (transfer, packaging, etc).

3- Release

At the end of the suction process, the vacuum is interrupted to release the object.

Most often, an air blow-off will help this process and avoid sticking. This also helps to quickly move to the next cycle.

VACUUM LEVELS AND SUCTION CUP SIZING

In practice, the majority of surfaces requiring suction are not airtight. If the material is porous or the surface is rough, it is inevitable that air will escape into the vacuum through the material or under the edges of the suction cup. In this situation, a high flow of vacuum must be maintained to compensate for air leaks and to maintain gripping. This can be done economically and efficiently at a low level of vacuum.

Within the recommended vacuum range of 30% to 80%, two distinct zones must be distinguished, depending on the nature of the object to be gripped..

1. Porous materials

The 30 to 55% vacuum zone is both economical and efficient, given the amount of vacuum flow required. The suction cups should be sized appropriately to obtain the required holding force.

2. Airtight surfaces

In this case, the 55 to 80% zone gives excellent results. The holding force is greater (curves opposite), so that smaller suction cups may be used.

Chapter 2 outlines a method for sizing the suction cups, particularly in relation to the chosen vacuum level.

1. Porous materials

Greater vacuum flow must compensate for products and processes that cause air leaks such as cardboard, agglomerated materials, rough wood, irregular surfaces, etc.

The most economic vacuum level is therefore between 30 and 55%.

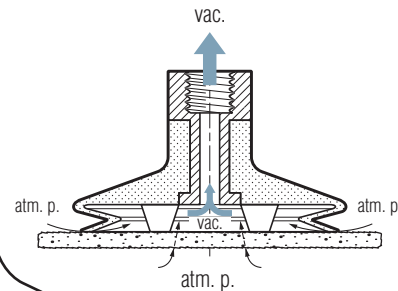

2. Airtight surfaces

With metal, plastics, glass and any other smooth, airtight surface, the vacuum flow required remains low, or even zero.

The vacuum level can therefore be higher, between 55 and 85%.

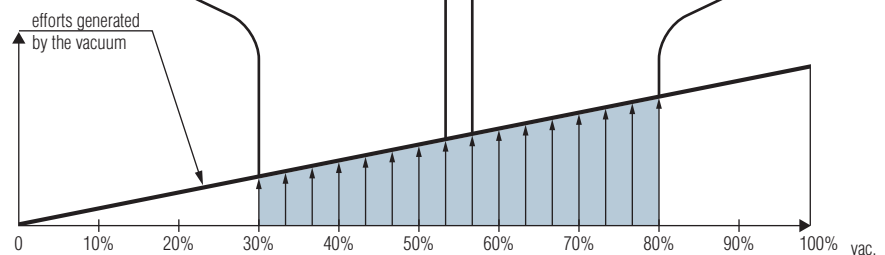
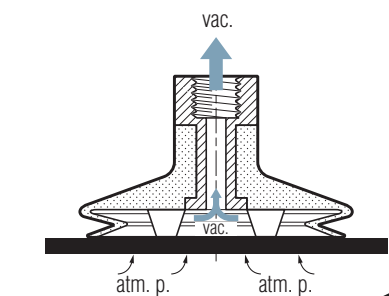

Vacuum Handling Guide

Vacuum Generation Technologies

1- CONTINUOUS VACUUM, USING ROTARY VACUUM PUMPS

Rotary Vacuum Pump Principle

The most commonly used type of rotary pump is the vane pump (illustration).

The blades are spun at high speed by the rotor, and the centrifugal force pushes them against the pump housing. The air is displaced and pushed out, creating a vacuum at the inlet.

For low vacuum levels only, turbines (or regenerative blowers) are also used, which operate in a similar manner to vacuum cleaners: a rotor with blades that do not make contact with the housing, causing air to move at high speed.

Range of Rotary Vacuum Pumps

To maintain optimum output, rotary pumps must remain within average power levels: from 1 to 10 Kw. The suction capacity generated is much higher than the normal requirements of industrial suction cups.

Operation Applications and Practice

Rotary pumps are used where a constant, high level of suction flow rate is required. Vacuum packaging machines are a typical example of this.

However, in the vast domain of vacuum gripping, rotary pumps are only used in rare instances, where an object requires a high level of suction flow rate that needs to be maintained for a long time during the cycle.

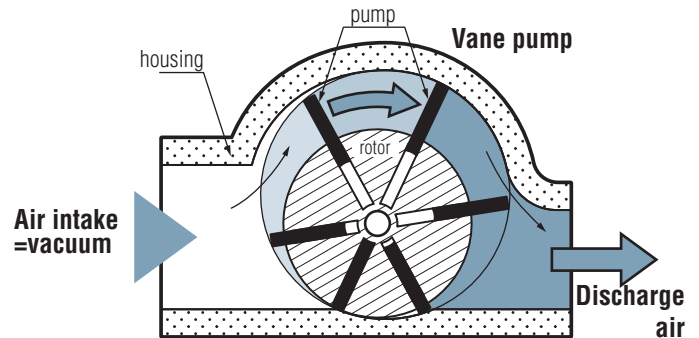

Rotary Vacuum Pumps	
<ul style="list-style-type: none"> • Constant consumption, continuous generation of vacuum, even for intermittent requirements: not suitable for intermittent vacuum generation requirements. • Located far from the suction cups. 	<p>Applications :</p> <ul style="list-style-type: none"> • Vacuum sources for various processes such as vacuum packing, etc. • Clamping maintained throughout the cycle, with high suction flow rate (porous objects etc.)

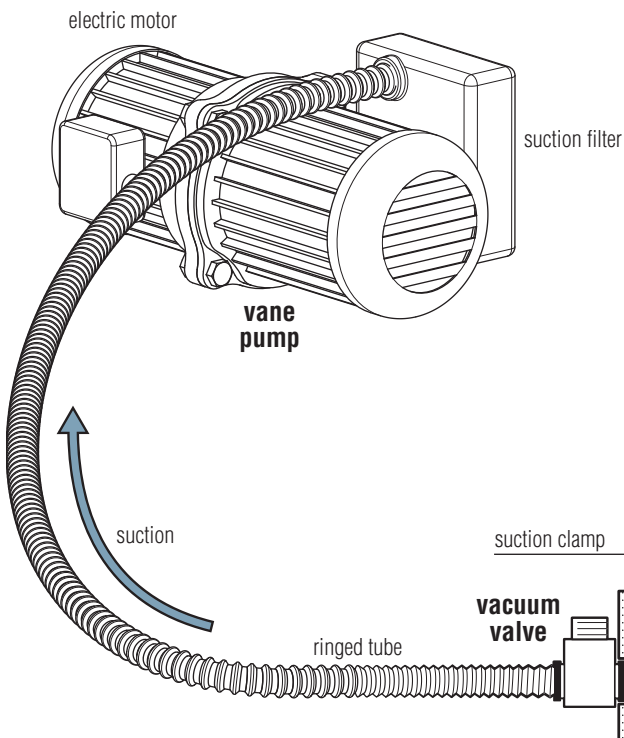

A Typical Application

The example shown below is a digital control manufacturing robot, which uses suction cups to clamp porous parts. Note that the pump, which is bulky, noisy and causes vibrations, must be installed well away from the operational section of the machine. It is connected via a tube, which must have a large diameter (40 to 80 mm) to reduce the loss of vacuum, which can sometimes be dangerous.

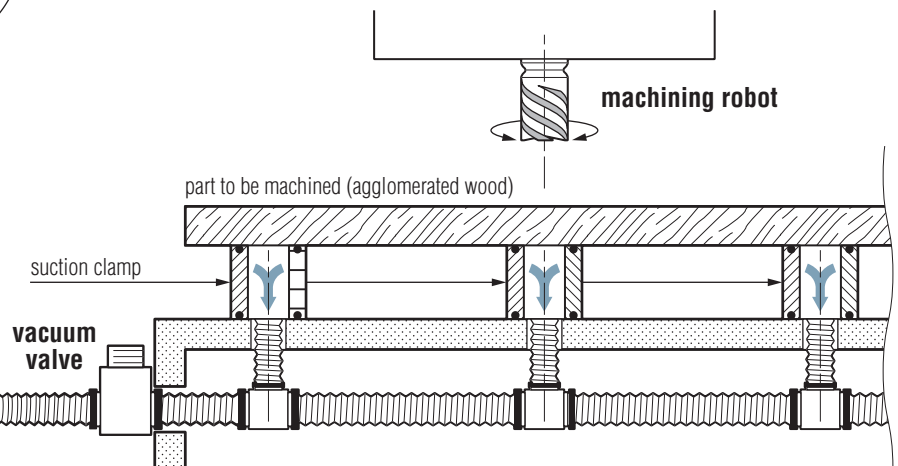

Vacuum Handling Guide

Vacuum Generation Technologies

INTERMITTENT VACUUM, USING VENTURI VACUUM PUMPS

Venturi Vacuum Pump Principle

Using the "venturi" effect : a nozzle of diameter \varnothing is supplied with compressed air. The air jet carries along ambient air in its turbulence and then passes through the mixer on its way out. This suction effect of ambient air creates the depression that generates the vacuum.

Unlike rotary vacuum pumps which must turn continuously, venturi vacuum pumps can operate intermittently, only when the suction cups require vacuum.

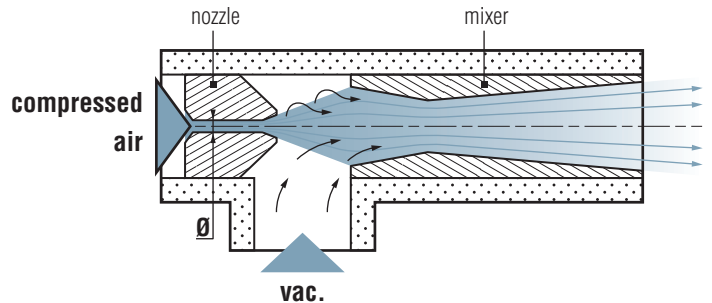

Venturi Vacuum Pumps	
<ul style="list-style-type: none"> • Consumption only when needed, results in low air consumption. • Installation very close to the suction cups. • Suction flow rate and vacuum level optimized for each application. 	<p>Applications :</p> <ul style="list-style-type: none"> • All intermittent gripping operations, i.e. which only last for a part of the full cycle of the machine

Venturi Vacuum Pump Ranges

The variations in nozzles and mixers offer an optimal range to meet all needs.

■ Nozzle diameter \varnothing

The diameter defines the force generated and therefore the suction capacity: \varnothing 0.5mm for micro suction cups, to \varnothing = 3mm with a suction capacity of 450 NI/min for several large suction cups.

■ Mixer profile

This profile defines the maximum level of vacuum achieved by the venturi.

Two standard levels offered by COVAL:

- 60% for porous material (30 to 55% vacuum)
- 85% for airtight materials (55 to 80% vacuum)

Max. vacuum ► 2 standard levels:

Applications and Practice

Venturi vacuum pumps are used for all normal vacuum gripping applications.

Compact and light, venturis are installed as close as possible to the suction cups: little pressure loss and a minimum volume to purge, resulting in short response times and minimum energy consumption.

The following distinguishes between:

- simple, pneumatically-controlled venturi pumps, which are miniaturized for installation on suction cups.
- complete, electrically-controlled venturi pumps, for installation as near as possible to the suction cups.

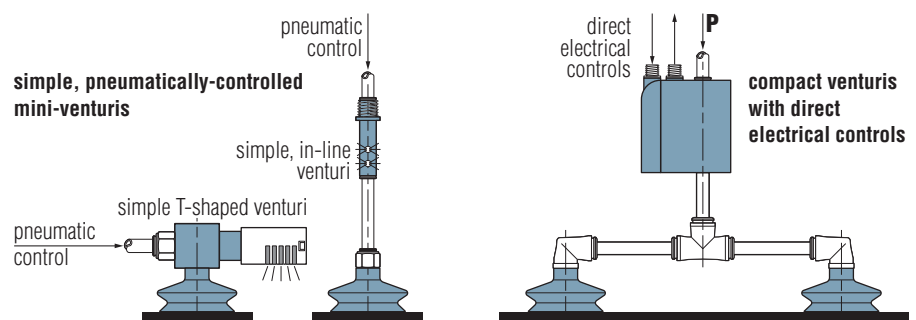
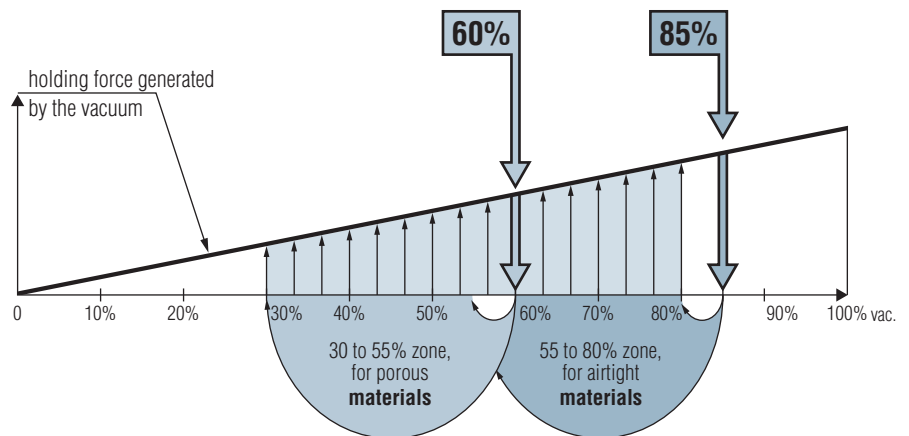

Vacuum Handling Guide

The Process of Defining an Installation

All vacuum handling systems require a three-stage approach:

1. Defining the appropriate suction cups and attachments for the object to be gripped, the movements required, the type of object (airtight or porous), the holding force required, the cycle rate, the environment, etc.
2. Selecting the appropriate vacuum generator for the suction cups, the type of object (airtight or porous), the required response times, etc.
3. Identifying the additional components required to connect, supply and control the installation.

The 3 steps to follow:

STEP 1: SUCTION CUPS AND THEIR ATTACHMENTS

COVAL offers a wide range of suction cups, in two main groups: standard and special purpose. Tailored solutions can also be developed according to a set of custom requirements.

Chapter 1 provides a detailed guide on how to choose a suction cup for a given application, among the wide range presented in chapters 2 and 4.



STEP 2: VACUUM GENERATORS AND THEIR MEANS OF CONTROL

Selecting the perfect vacuum source for the suction cups used guarantees optimal productivity.

COVAL has developed a full range of venturi vacuum pumps using the most advanced technologies: optimized flow rates, low energy consumption, reduced weight and bulk, and silent operation. Numerous integrated functions mean they are easier and more economic to install and use.

Chapter 5 provides a guide starts with a guide to choose and configurate a venturi among the many possibilities presented in the catalogue, from vacuum pump chapter 6 to 9.



STEP 3: AUXILIARY COMPONENTS

Peripheral components are an essential addition to the vacuum network and guarantee reliable installation. The risks related to improper use are increased energy consumption and noise and decreased overall efficiency.

Chapters 4 and 14 present a wide variety of auxiliary components

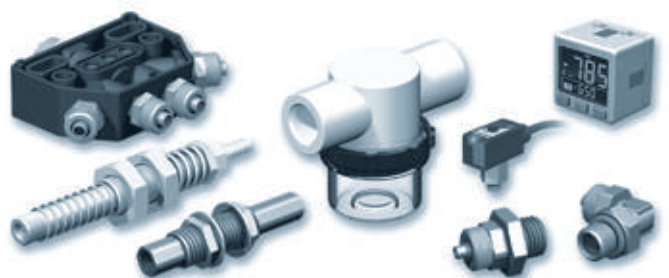

Suction Cups

Chapter 1

Selection Guide	p. 1/2
Suction Cup Assembly Options	p. 1/6
Assembly Reference: "Suction Cup + Fitting"	p. 1/7
The COVAL Range	p. 1/8
Index of Pictograms and Symbols	p. 1/11

Suction Cups

Selection Guide

1

A suction cup is a gripper which can be used to handle all sorts of objects of different weights, surfaces, shapes and sizes. For this reason we feel it would be helpful to explain all the parameters to be taken into consideration, in order to choose the right suction cup.



PARAMETERS TO BE TAKEN INTO CONSIDERATION WHEN CHOOSING A SUCTION CUP

Shape of the load	Flat • Rounded • Cylindrical • Egg-shaped • Spherical, etc.
Type of material of the load	Porous • Porous • Deformable • Rigid • Fragile, etc.
Condition of the surface of the load	Smooth • Granular • Ridged • Abrasive, etc.
Appearance of the load	Damp • Oily • Dusty • Viscous • Dry, etc.
Weight of the load	Heavy • Light, etc.
Temperature of the load	From -40 to 250°C / -40 to 482°F depending on the materials chosen.
Direction of gripping	Horizontal • Vertical • Over corners • Height differences, etc.
Type of grip	Handling • Lifting • Holding • Unfolding ... objects.
Available surface	Depending on the load
Cycle time	Accelerations

THE SHAPES

Flat Suction Cups

■ Flat suction cups without cleats
Used for handling flat or slightly rounded, rigid, smooth objects. They withstand lateral forces and can be used for vertical handling.



■ Flat suction cups with cleats
Used for handling thin, flexible, deformable objects. They increase resistance to lateral forces and horizontal handling.

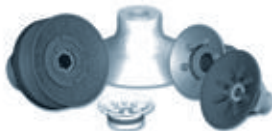

Suction Cups with Bellows

Used to handle spherical, cylindrical or egg-shaped objects. The effect of the technical characteristics increases with the number of bellows.

They can be used for gripping objects with height differences, for a ball-joint effect, to lift and to grip corners or edges.



SUCTION CUP FORCE CALCULATION

The force of a suction cup is proportional to its surface under vacuum and also depends on its shape, flexibility, material and especially on the level of vacuum attained inside the suction cup.

Theoretical force

$$F(\text{DaN}) = S (\text{cm}^2) \times V (\%) \times 0,01013$$

S = Surface of the suction cup (cm²)
V = Vacuum level (%)

Actual force

As its name implies, this force represents the actual force of the suction cup when in use. In general this is 50% less than the calculated theoretical force. This difference is explained by the distortion of the suction cup during handling (which reduces the gripping surface), and by the condition of the surface of the object being handled.

The safety factor

All holding forces are listed in the data tables for each range of suction cup. These are **actual values at 65% vacuum**, calculated with a safety factor of:

- 2 for horizontal gripping (1),
- 4 for vertical gripping (2).

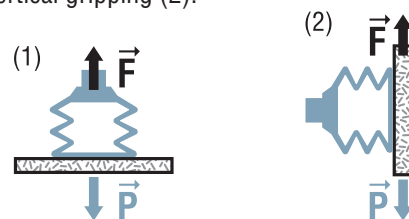

For applications involving high acceleration, the safety factor will be calculated accordingly.

Suction Cups

Selection Guide

SUCTION CUP TECHNICAL DATA

Diameters

The force of the suction cup and the product's available gripping surface depend on this parameter. COVAL offers standard suction cups of 1 to 600mm in diameter across the product ranges.



Internal volume

This corresponds to the volume which must be evacuated during a vacuum cycle. It must be accounted for in the total volume of the gripping system and thus in the suction time calculation.



Minimum bend radius

This indicates the minimum radius of a product to be reliably gripped by the suction cup.



Stroke

This corresponds to the compression of the suction cup during the vacuum cycle.

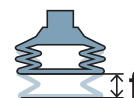

COVAL MATERIALS

To meet the constraints of industrial applications, COVAL has a wide range of both standard and specific materials. COVAL can also study new materials based on specific requirements of your applications.



Properties of the materials

Materials	Abbreviation	Shore Hardness A (+/- 5 Shore A)	Color	Flexibility	Abrasion resistance	UV & weather resistance	Mineral oil resistance	Continuous temperature resistance		Food compatibility	
								in °C	in °F	FDA CFR 21 177.2600	CE 1935/2004
Nitrile	NBR	60	Black	+	++	+	++	0 to 90	32 to 194		
	SI	35	Translucent	++++	-	+++	-	-40 to 220	-40 to 428	■	■
	SI3	35	Red	++++	-	+++	-	-40 to 220	-40 to 428	■	■
	SI5	50	Translucent	+++	-	+++	-	-40 to 220	-40 to 428	■	■
	SIB	35	White	++++	-	+++	-	-40 to 220	-40 to 428	■	■
	SIBL3	35	Light blue	++++	-	+++	-	-40 to 220	-40 to 428	■	■
	SIBL5	50	Dark blue	+++	-	+++	-	-40 to 220	-40 to 428	■	■
	SI5BD (detectable)	50	Dark blue	+++	-	+++	-	-40 to 220	-40 to 428	■	■
	SIT3	35	Translucent	++++	-	+++	-	-40 to 220	-40 to 428	■	■
	SIT5	50	Translucent	+++	-	+++	-	-40 to 220	-40 to 428	■	■
SIT6	60	Translucent	++	-	+++	-	-40 to 220	-40 to 428	■	■	
Natural Rubber	NR	50	Grey - Brown	+++	++	-	-	-20 to 70	-4 to 158		
SITON®	STN	60	Blue	+	+++	++	++	-20 to 130(*)	-4 to 266(*)		
	STN5	50	Blue	++	+++	++	++	-20 to 130(*)	-4 to 266(*)		
	STNV6	60	Green	+	+++	++	++	-20 to 130(*)	-4 to 266(*)		
Polyurethane	PU	60	Blue	+	+++	+	+++	-20 to 90	-4 to 194		
	TPU	85	Blue grey	-	+++	+	+++	-20 to 100	-4 to 212		

(*) Resistance to temperature on a single contact point (< 5 s): 160 °C / 320 °F

- ++++ Excellent
- +++ Very good
- ++ Good
- + Weak
- Not applicable
- Compatible

Suction Cups

Selection Guide

1

► SITON® MATERIAL SUCTION CUPS

SITON®, developed and manufactured exclusively by COVAL, is a non-marking silicone-free material specially designed for handling hot plastic parts from injection molds.

Advantages of SITON® material

- Non-marking: clear, silicone-free compound.
- Withstands continuous temperatures of 130°C (266°F) up to 160°C (320°F) at peak.
- Excellent abrasion resistance.

Many suction cup models are available in SITON® 60 Shore A (STN) in this catalog. For greater flexibility, models in SITON® 50 Shore A (STN5) are available upon request.



Temperature range for COVAL materials

Each material has a specific temperature range of use:

- range for extended use.
- range for occasional use (contact time < 5s).

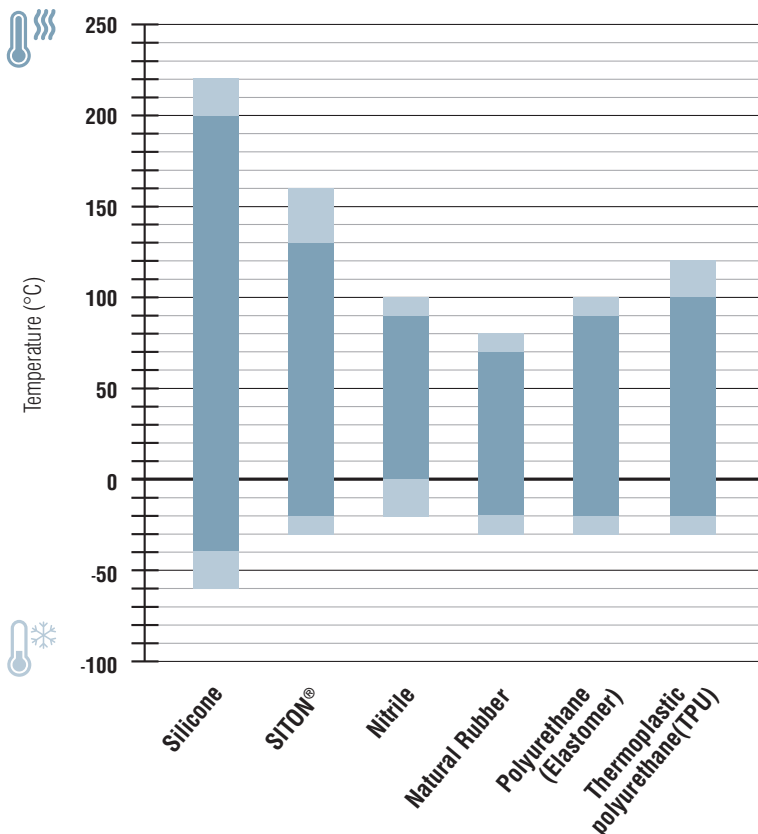

Use of suction cups outside their temperature range of use, wear, damage (cracking) or permanent change of shape (high temperatures) can appear.



Chemicals may be incompatible with the suction cup material and cause swelling or damage.

Suction Cups

Selection Guide

Characteristics of COVAL materials

NITRILE (NBR)

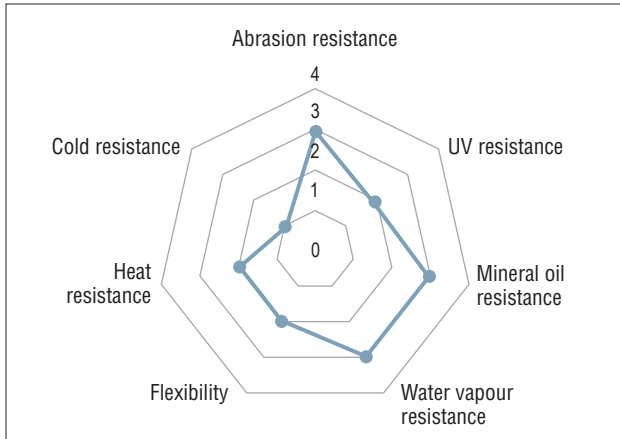

SITON® (STN)

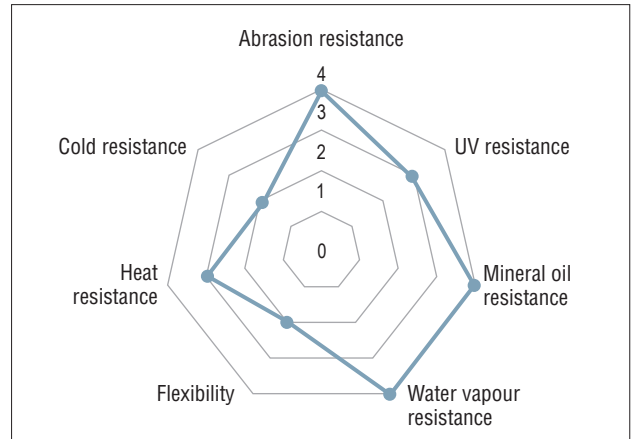

NATURAL RUBBER (NR)

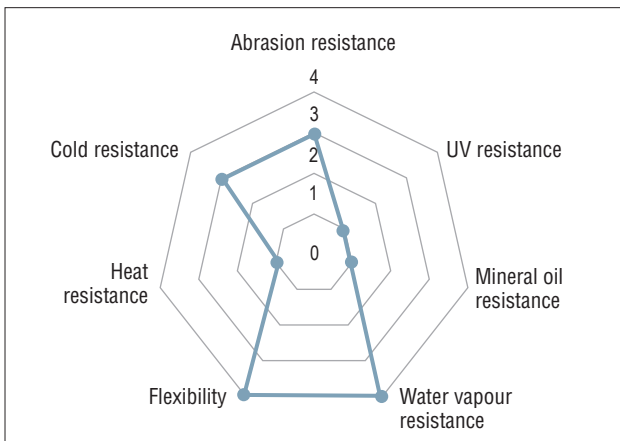

SILICONE (SI_SIT_SIB_SIBL)

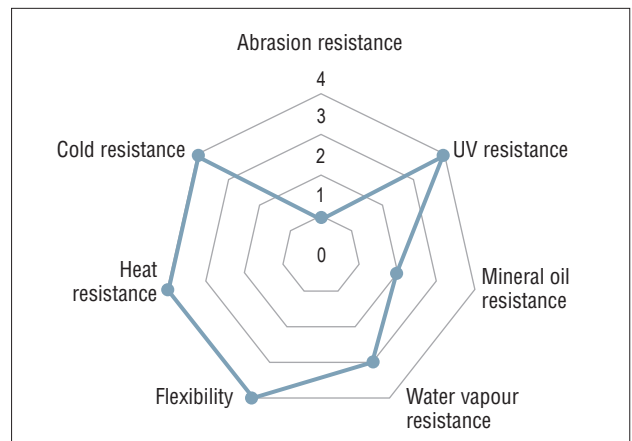

POLYURETHANE (PU)

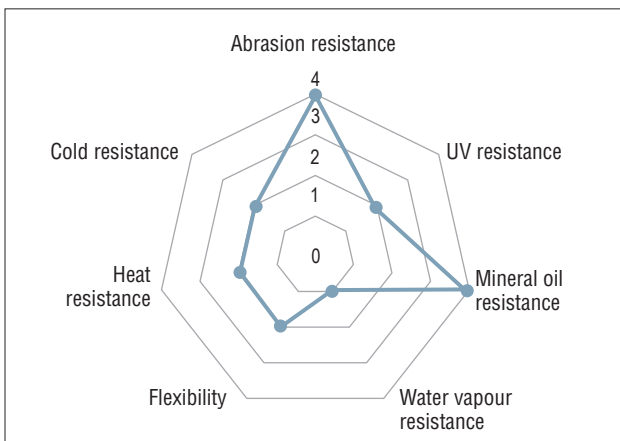

THERMOPLASTIC POLYURETHANE (TPU)

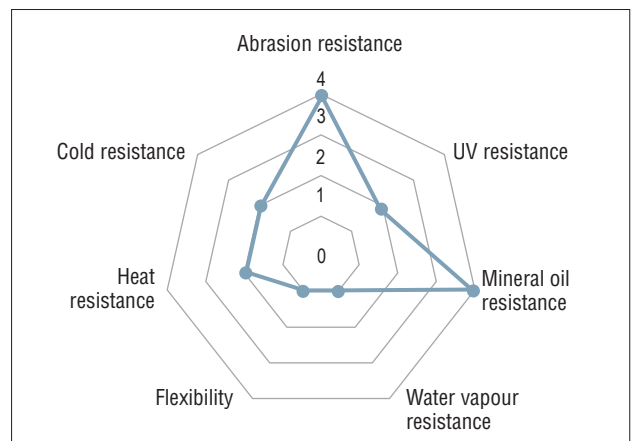

Suction Cups

Suction Cup Fitting Options

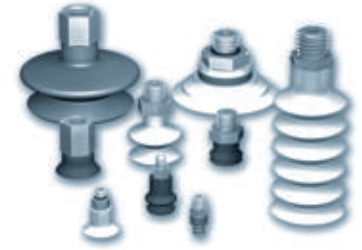

1

Standard Configuration Options

COVAL suction cups offer versatile mounting and fitting options:

Version C:
Barbed fittings.

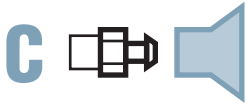

The suction cup is easily pressed onto the fitting.
The suction cups and their fittings are delivered unassembled.

Types of use:

- Lightweight products.
- Horizontal handling.
- For suction cups belonging to groups 1 and 2.

Advantages :

- Quickest changeout of suction cups without the need for tools, improving efficiency.
- Fitting can be reused, thus reducing replacement costs.

Version V :
2-piece removable fittings
(hollow screws and adapter)

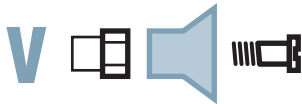

The V mounting utilizes a hollow screw passing through the suction cup and connecting to an adaptor on the opposite side, fixing the suction cup in place.
The suction cups and their fittings are delivered unassembled.

Types of use :

- Heavy and lightweight products.
- Horizontal, vertical and rotational handling.
- For suction cups belonging to groups 2 and 3.

Advantages :

- Excellent mechanical grip of the suction cup.
- Excellent vacuum sealing of the assembly.
- Fitting can be reused, thus reducing replacement costs.

Version E :
Pressed fitting
(removable).

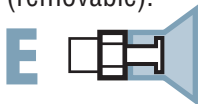

The fitting is factory pressed onto the suction cup.

Types of use :

- Lightweight and heavy products.
- Horizontal, vertical and rotational handling.
- Recommended for handling of porous products.
- For suction cups belonging to group 2.

Advantages :

- Excellent mechanical grip of the suction cup.
- Excellent vacuum sealing of the assembly.
- Greater potential vacuum flow rate when handling porous products.

Version S :
Factory-crimped fitting

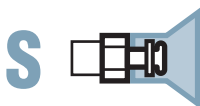

The fitting is factory-crimped onto the suction cup, ensuring a one-piece assembly.

Types of use :

- Heavy and lightweight products.
- Horizontal handling, vertical and rotational.
- Recommended for handling of porous products (when greater flow is required).
- For suction cups belonging to group 3.

Advantages :

- Excellent mechanical grip of the suction cup.
- Excellent vacuum sealing of the assembly.
- Greater potential vacuum flow rate when handling porous products.

Suction Cups

Configuration Reference "Suction Cup + Fitting"



1

Referencing

To simplify selection of fittings for standard suction cups, a male or female fitting option can be found in the example table, "**Choice of fittings**".

To demonstrate assembly options, reference the example below, **Standard configurations** (suction cup + fitting) which indicates full part numbers as well as **non-standard configurations**.

Ex :

Choice of Fittings

∅	Group	M3-M	M5-M	M6-M	M8-M	M10-M	G1/8"-F	G1/8"-M	10/32-M	G1/4"-F	G1/4"-M	G3/8"-M	G1/2"-M
5	1	■	-	-	-	-	-	-	-	-	-	-	-
11...25	1	-	■	■	-	-	■	■	□	-	-	-	-
26...63	2	-	□	□	□	□	■	■	-	■	■	-	-
78	3	-	-	-	-	□	-	■	-	■	■	□	□

■ Standard configurations (suction cup + fitting)

□ Non-standard mounting configurations

Fitting: M = male F = female

Standard configurations (suction cup + fitting) now have a single part number, simplifying your stock management and order fulfillment.

Ex:

Group 3		V			S	
∅ 78 mm	THREAD	G1/8"-M	G1/4"-M	G1/4"-F	G1/4"-M	G1/4"-F
	VSA78NBR	VSA78NBRIM18V	VSA78NBRIM14V	VSA78NBRIF14V	VSA78NBRIM14	VSA78NBRIF14
	VSA78NR	VSA78NRIM18V	VSA78NRIM14V	VSA78NRIF14V	VSA78NRIM14	VSA78NRIF14
	VSA78SIT5	VSA78SIT5IM18V	VSA78SIT5IM14V	VSA78SIT5IF14V	VSA78SIT5IM14	VSA78SIT5IF14
	VSA78STN	VSA78STNIM18V	VSA78STNIM14V	VSA78STNIF14V	VSA78STNIM14	VSA78STNIF14

Note :

For standard configurations (suction cup + fittings), the C and V versions are delivered unassembled.

Additional mounting configurations are available. You can find all options on pages "assembly diagrams"

Ex:

Removable fittings V

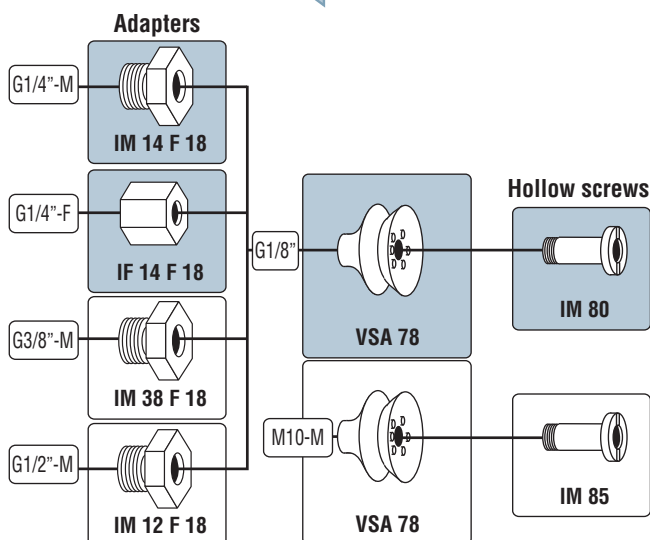

■ Standard configurations (suction cup + fitting).

□ Non-standard configurations must be ordered in separate part numbers.

Suction Cups

The COVAL Range







See chapter 2

1

Standard Suction Cups

Standard suction cups are suitable for all types of applications in various sectors like packaging, plastics, agri-food, sheet-metal working, etc.

These suction cups satisfy very diverse specifications thanks to a wide range of shapes, diameters and materials. COVAL offers a full range of fittings adapted to suction cups and compatible with all types of applications.

Flat Suction Cups			
VP		<ul style="list-style-type: none"> ■ Ø 8 to 75 mm ■ 4 standard materials 	<ul style="list-style-type: none"> ■ High tensile force and precise gripping and releasing ■ High resistance to lateral forces allowing vertical handling
VPG		<ul style="list-style-type: none"> ■ Extra-flat suction cups ■ Ø 2 to 200 mm ■ 3 standard materials 	<ul style="list-style-type: none"> ■ Highly precise gripping and releasing of the load ■ High throughput rates
VPU		<ul style="list-style-type: none"> ■ Ø 6 to 50 mm ■ 3 standard materials 	<ul style="list-style-type: none"> ■ Suitable for gripping rigid and flat products
VPF		<ul style="list-style-type: none"> ■ Flat suction cups with cleats ■ Ø 15 to 50 mm ■ 3 standard materials 	<ul style="list-style-type: none"> ■ Suitable for gripping rigid and flat products ■ Cleats prevent the deformation of the product and provide excellent non-slip properties
VPO		<ul style="list-style-type: none"> ■ Flat oblong suction cups ■ From 2x4 mm to 30x90 mm ■ 3 standard materials 	<ul style="list-style-type: none"> ■ Used for handling elongated products such as pens, tubes, bottles, bulbs and flat or cylindrical objects etc.
Suction Cups with 1.5 Bellows			
VSA		<ul style="list-style-type: none"> ■ Ø 5 to 78 mm ■ 5 standard materials 	<ul style="list-style-type: none"> ■ Combines the advantages of flat suction cups with added angle, flexibility and precision ■ Used for gripping slightly concave or convex parts
VSAB		<ul style="list-style-type: none"> ■ Ø 5 to 50 mm ■ 3 standard materials 	<ul style="list-style-type: none"> ■ Used for gripping slightly concave or convex parts ■ Suitable for gripping products of various heights
VSAG		<ul style="list-style-type: none"> ■ Ø 10 to 150 mm ■ 3 standard materials 	<ul style="list-style-type: none"> ■ Recommended for gripping sensitive products due to the cushioning effect of the bellows ■ Used for gripping slightly concave or convex parts
VSAJ		<ul style="list-style-type: none"> ■ Ø 15 to 30 mm ■ 2 standard materials 	<ul style="list-style-type: none"> ■ Used for gripping slightly concave or convex parts ■ Suitable for gripping products of various heights
Suction Cups with 2.5 Bellows			
VS		<ul style="list-style-type: none"> ■ Ø 5 to 88 mm ■ 4 standard materials 	<ul style="list-style-type: none"> ■ Recommended for gripping products on different planes (wide deflection) or cylindrical objects gripped at an angle (ball-joint effect).
VSG		<ul style="list-style-type: none"> ■ Ø 5 and 7mm ■ 3 standard materials 	<ul style="list-style-type: none"> ■ Suitable for gripping small products, concave or convex ■ Ideal for handling sensitive products
Long Stroke Suction Cups			
VSD		<ul style="list-style-type: none"> ■ Suction cups with 4.5 and 5.5 bellows ■ 2 standard materials 	<ul style="list-style-type: none"> ■ Strongly recommended for handling spherical or cylindrical products requiring a large height adjustment.
High-performance Suction Cups			
C		<ul style="list-style-type: none"> ■ Full range of shapes (flat, bellows, oblongs) ■ Ø 35 to 125mm and 25x65mm to 70x140mm ■ Integrated fittings ■ Structure and internal cleats 	<ul style="list-style-type: none"> ■ Textured suction cups for gripping thin sheets ■ Non-slip cleats ensure optimum positioning of oily sheet metal ■ Extreme resistance to slipping, ■ Porous integrated fittings ■ Ideal for automated applications
CTC		<ul style="list-style-type: none"> ■ High-Performance Bell-type Suction Cups in Thermoplastic Polyurethane (TPU) ■ 4 models (Ø40 à 100 mm) ■ Integrated fittings ■ Structure and internal cleats 	<ul style="list-style-type: none"> ■ Excellent adaptation to convex surfaces and angular shapes. ■ High deflection compared to standard flat suction cups due to the bell shape. ■ Anti-slip cleats ensure precise positioning of oily sheets. ■ Ideal for automated applications
Suction Cups with Foam Rings			
VSA-VS BM VSA-VS BM-SIF VSBM		<ul style="list-style-type: none"> ■ Foam rings ■ Can be adapted to standard suction cups ■ 2 standard materials 	<ul style="list-style-type: none"> ■ Bonded under a suction cup to allow products with an irregular or even-ridged surface to be gripped ■ Sawn wood, sheet metal, flat surfaces with bumps or hollows (all types of granular surface)

Suction Cups

The COVAL Range













See chapter 3

1

Special Purpose Suction Cups

Thanks to a technological mastery and collaboration with its customers in different branches, COVAL supplies solutions for vacuum handling via a wide range of special purpose suction cups.

E.g. handling eggs, flexible bags, raw composite, bottles, paper, cakes, etc.

FlowPack Suction Cups		
FPC FPCX 	<ul style="list-style-type: none"> Flexible suction cups 5 models Food-safe materials Silicone: FDA and CE standard 	<ul style="list-style-type: none"> Range specially designed for gripping flexible packaging Thin and wavy lips mold perfectly to any shape of packaging Gripping ability allows for high production rates
Soft Suction Cups for High Speed Applications		
MVS 	<ul style="list-style-type: none"> Suction cups with 1.5 and 2.5 bellows 9 models Silicone: FDA and CE standard 	<ul style="list-style-type: none"> Used to grip delicate objects. Very flexible lip (opening bags, gripping tins and flexible aluminum or plastic bottles, etc.). High throughput rate Used to grip of flexible products
Suction Cups with 4.5 Bellows		
MVP 	<ul style="list-style-type: none"> Suction cups with 4.5 bellows 4 diameters available: 20 to 50 mm Materials: nitrile and silicone (FDA and CE standards) 	<ul style="list-style-type: none"> The handling of raw food or flexible packaging Thin and flexible shaped lip for a perfect handling at high production rates The 4.5 bellows give a swivelling effect
Suction Cups for Cheese		
VSAF 	<ul style="list-style-type: none"> Suction cup with 1.5 bellows Ø 50 mm Silicone: FDA and CE standard 	<ul style="list-style-type: none"> Suction cup specially designed for gripping fragile foods such as soft cheese Accessory: Stainless steel grill prevents deformation of the food
VSAOF 	<ul style="list-style-type: none"> Oval suction cup with 1.5 bellows Dim. 65x150 mm Silicone: FDA and CE standard 	<ul style="list-style-type: none"> Suction cup specially designed for gripping fragile foods such as soft cheese Accessory: Stainless steel grill prevents deformation of the food
Suction Cups for Bakery Applications		
VSD VSE VSP 	<ul style="list-style-type: none"> Suction cups with 2.5 to 5.5 bellows 11 models Silicone: FDA and CE standard 	<ul style="list-style-type: none"> Range specially developed for gripping delicate objects such as cakes (buns, biscuits, etc.) Specific shapes and shore A hardness depending on the applications Resistance to temperature: - 40 °C to + 220 °C
Suction Cups for Egg-handling		
VSO 	<ul style="list-style-type: none"> Suction cups with 2.5 and 3.5 bellows 3 models Silicone: FDA and CE standard 1935/2004 	<ul style="list-style-type: none"> Range specially designed to meet constraints involved when handling eggs Very flexible lip Different shapes of suction cup
Suction Cups for Bottle Handling		
VSBO VSBO+ VSBO LM/BM 	<ul style="list-style-type: none"> Suction cups with 4.5 bellows 8 models High tensile force Highly flexible and long stroke 	<ul style="list-style-type: none"> Used to grip 750 ml bottles, Magnums bottles and special bottles with textured surfaces Bottles gripped from the side, vertical and horizontal handling Suction cup with stainless steel reinforcement in the bellows Available with integrated sensing valve
VBO 	<ul style="list-style-type: none"> Suction cup system comprised of a 62mm cup with 2.5 bellows and a silicone gripping disc (COVAL-Flex). 	<ul style="list-style-type: none"> The VBO suction cup system is designed for gripping bottles by the punt on disgorging stations Excellent sealing when gripping different types of bottles
VPBO 	<ul style="list-style-type: none"> Coupler Plates for gripping bottles by the punt 3 diameters: Ø65, 75 and 95 mm Natural rubber 	<ul style="list-style-type: none"> The VPBO Coupler Plates are designed for gripping bottles by the punt on disgorging stations (1/2 bottles, 75cl bottles and Magnum)



Suction Cups

The COVAL Range











Special Purpose Suction Cups

See chapter 3

1

Suction Cups for Paper Applications

VPA		<ul style="list-style-type: none"> Flat suction cups 9 models Very flexible lip Natural rubber and silicone (FDA and CE standard) 	<ul style="list-style-type: none"> Range of suction cups with very flexible lip used to handle very flexible materials Very resistant to abrasion (for paper, cardboard) Very flexible gripping lip which molds to the shape of the object to be handled
VPAL		<ul style="list-style-type: none"> Extra-flat shape suction cups 3 models Material: silicone (food compatibility) 	<ul style="list-style-type: none"> The VPAL suction cups are especially adapted for gripping and handling IML labels or flexible materials Great lip flexibility
VSAPL		<ul style="list-style-type: none"> Suction cup with 1.5 bellows Ø 11 mm Silicone: FDA and CE standard 	<ul style="list-style-type: none"> The VSAPL suction cup is especially adapted for gripping and handling IML labels or flexible materials Great lip flexibility
VPR		<ul style="list-style-type: none"> Flat suction cups 4 models Natural rubber 	<ul style="list-style-type: none"> Range of suction cups designed to meet the requirements of mailing applications. Envelope stuffing, film-wrapping, mailing (picking) Very resistant to abrasion
VPAG		<ul style="list-style-type: none"> Curved suction cups 2 models Natural rubber 	<ul style="list-style-type: none"> Thanks to very flexible lips and a curved shape, the VPAG range is adapted to gripping flexible materials such as labels or sheets of paper - or textured objects Very resistant to abrasion
Ultra-flat, Non-Marking Suction Cups			
VPSC		<ul style="list-style-type: none"> Ultra-flat suction cups Ø 40 and 80 mm Materials : Polyurethane and silicone (FDA and CE standards) 	<ul style="list-style-type: none"> Suction cups specially designed not to deform the product being handled. Vacuum distributed across the entire surface of the suction cup for an optimal gripping force. Extra-thin sealing lip designed to contour to the shape of the product being handled
Radial Ball-joint Suction Cups			
VPYR		<ul style="list-style-type: none"> Flat suction cups with ball-joint system 4 models (Ø 50 to 100mm) Materials: nitrile and silicone 	<ul style="list-style-type: none"> The range of ball-joint suction cups is recommended for gripping curved or rotating products which requires a lot of force and mechanical resistance
"Heavy-load" Suction Cups			
SPL		<ul style="list-style-type: none"> "Heavy load" flat suction cups 5 models (Ø 240 to 600mm) Materials: nitrile and silicone 	<ul style="list-style-type: none"> SPL suction cups are used to handle heavy loads such as sheet metal or glass panels. They have internal cleats allowing them to handle thin metal sheets without distorting them and for vertical handling (non-slip)
STEEL		<ul style="list-style-type: none"> Flat suction cups with a bonded foam seal 9 round models (Ø 150 to 580 mm) 9 rectangular models (175x115 to 705x385mm) 	<ul style="list-style-type: none"> For horizontal handling of heavy loads (thick sheet metal) or objects with an uneven surface such as concrete slabs, wood, etc. Wide choice of dimensions











Suction Cups

Index of Symbols and Pictograms



You will find the symbols and pictograms described below in the "Suction cups" chapters to help you select the range of suction cups best suited to your application.









Industry-specific Applications

- | | |
|-------------------------------------------------------------------------------------------------------------------------------------------------------------------------------------------------------------------------------------------------------------------------------------------------------------------------------------------------------|---------------------------------------------------------------------------------------------------------------------------------------------------------------------------------------------------------------------------------------------------------------------------------------------------------------------------------------------------------------------------------------------------------------------|
|  <p>Metal
For handling rigid, smooth, flat objects (e.g. Sheet metal, glass or plastic panels).
 <ul style="list-style-type: none"> ■ Heavy loads ■ Oily objects ■ High throughput ■ High acceleration </p> |  <p>Food-processing
Handling that requires materials which are compatible with food standards, highly flexible lips and suction cup shapes that do not damage fragile products.
 <ul style="list-style-type: none"> ■ Handling of raw products such as cheese, meat, fish or packaged products. </p> |
|  <p>Plastic
For handling plastic objects and requiring resistance to high temperatures, mark-free (e.g. COVAL-developed material, SITON®).</p> |  <p>Wood
For handling materials with a slightly deformed, rough gripping surface requiring a foam seal to compensate for the unevenness and ensure porousness.</p> |
|  <p>Eggs
For handling requiring food compatibility, a very flexible lip and a specific shape of suction cup.
 <ul style="list-style-type: none"> ■ Gripping eggs </p> |  <p>Cakes
For handling requiring food compatibility, a very flexible lip and a specific shape of suction cup.
 <ul style="list-style-type: none"> ■ Gripping buns, biscuits, etc. </p> |
|  <p>Bottles
Gripping concave shapes and requiring strong vertical lifting force.
 <ul style="list-style-type: none"> ■ For handling 750 ml bottles or Magnums </p> |  <p>Paper/picking
For handling paper, and labels and requiring high resistance to abrasion and a very flexible lip to grip flexible materials.
 <ul style="list-style-type: none"> ■ Envelope filling, film-wrapping </p> |
|  <p>Composite materials
Gripping of raw composite materials.
 <ul style="list-style-type: none"> ■ No material migration ■ No marking of the composite product </p> |  <p>Bags
Gripping very flexible, deformable materials (plastic or paper).
 <ul style="list-style-type: none"> ■ e.g. blister pack, bagging, etc. </p> |
|  <p>Packaging
For handling wrapped products for packaging, cardboard products. Cardboard shaping, palletization, transfer, Pick & Place.
 <ul style="list-style-type: none"> ■ Precision ■ Abrasion </p> | |

Types of Use

- | | | | | | | |
|-------------------------------------------------------------------------------------|-------------------------------------------------------------------------------------|-------------------------------------------------------------------------------------|-------------------------------------------------------------------------------------|--------------------------------------------------------------------------------------|---------------------------------------------------------------------------------------|---------------------------------------------------------------------------------------|
|  |  |  |  |  |  |  |
| Flat surfaces,
all thicknesses | Flat surfaces,
thin layers | Rounded
surfaces | Sheet metal
(unstacking) | Flexible
materials | Vertical
handling | Granular
surfaces |

Tables

							
Model or reference	Internal volume	Tensile force	Slipping force	Minimum convex curve radius	Minimum concave curve radius	Weight	See page

Standard Suction Cups

Chapter 2

2

COVAL QUALITY

Standard suction cups are suitable for all types of applications in areas of activity such as packaging, plastics, agri-food, sheet-metal working, etc.

These suction cups satisfy very diverse specifications thanks to a wide range of shapes, diameters and materials. COVAL offers a full range of fittings adapted to suction cups and compatible with all types of applications.

VP



Flat Suction Cups Ø 8 to 75 mm

4 standard materials

- Nitrile
- Silicone
- Natural rubber
- SITON®
- High tensile force and precise gripping and releasing
- High resistance to lateral forces enabling vertical handling
- A full range of fittings and shut-off valves

P 2/3

VPG



Extra-flat Suction Cups Ø 1 to 200 mm

3 standard materials

- Nitrile
- Silicone
- SITON®
- Highly precise gripping and releasing of the load
- High throughput rates

P 2/9

VPU



Flat Suction Cups Ø 6 to 50 mm

3 standard materials

- Nitrile
- Silicone
- SITON®
- Suitable for gripping smooth, rigid and flat products

P 2/17

VPF



Flat Suction Cups with Cleats Ø 15 to 50 mm

3 standard materials

- Nitrile
- Silicone
- SITON®
- Suitable for gripping smooth, rigid and flat products
- Cleats prevent the deformation of the product

P 2/20

VPO

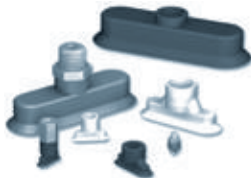

Oblong Flat Suction Cups

3 standard materials

- Nitrile
- Silicone
- SITON®
- Used for handling elongated products such as pens, tubes, bottles, bulbs and flat or cylindrical objects etc.

P 2/23

VSA



Suction Cups with 1.5 Bellows Ø 5 to 78 mm

5 standard materials

- Nitrile
- Translucent silicone
- 35 shore A white silicone
- Natural rubber
- SITON®
- VSA series suction cups with bellows combine the advantages of flat suction cups with more deflection, flexibility and precision
- Used for gripping slightly concave or convex parts
- Full range of fittings

P 2/27

VSAB



Suction Cups with 1.5 Bellows Ø 5 to 50 mm

3 standard materials

- Nitrile
- Silicone
- SITON®
- Used for gripping slightly concave or convex parts
- Suitable for gripping products of various heights

P 2/33

VSAG



Suction Cups with 1.5 Bellows Ø 10 to 150 mm

3 standard materials

- Nitrile
- Silicone
- SITON®
- Recommended for gripping products sensitive to the cushioning effect of the bellows
- Used for gripping slightly concave or convex parts

P 2/37

Standard Suction Cups

Chapter 2

VSAJ



Suction Cups with 1.5 Bellows Ø 15 to 30 mm

- 2 standard materials
- Nitrile
- Silicone

- Used for gripping slightly concave or convex parts
- Suitable for gripping products of various heights

P 2/43

VS



Suction Cups with 2.5 Bellows Ø 5 to 88 mm

- 4 standard materials
- Nitrile
- Natural rubber
- Translucent silicone
- SITON®

- VS series suction cups with bellows are recommended for gripping products on different planes (wide deflection) or cylindrical objects gripped at an angle (ball-joint effect).
- Full range of fittings

P 2/47

VSG



Suction Cups with 2.5 Bellows Ø 5 and 7 mm

- 3 standard materials
- Nitrile
- Silicone
- SITON®

- Suitable for gripping small products, concave or convex
- Ideal for handling sensitive products

P 2/53

VSD



Long Stroke Suction Cups

- 2 standard materials
- Nitrile
- Silicone

- Strongly recommended for handling spherical or cylindrical products requiring a large height adjustment.

P 2/55

C



High-performance Suction Cups

- Full range of shapes (flat, bellows, oblongs)
- Ø 35 to 125mm and 25x65mm to 70x140mm
- 2 standard materials
- Nitrile
- SITON®
- Integrated fittings

- Textured suction cups for gripping thin sheet metal
- Non-slip cleats ensure optimum positioning of oily sheet metal
- Extreme resistance to slipping
- Air-tight integrated fittings
- Ideal for automated applications

P 2/59

CTC



High-performance Suction Cups

- High-Performance Bell-type Suction Cups in Thermoplastic Polyurethane (TPU)
- 4 models (Ø40 à 100 mm)
- Integrated fittings
- Structure and internal cleats

- Excellent adaptation to convex surfaces and angular shapes.
- High deflection compared to standard flat suction cups due to the bell shape.
- Anti-slip cleats ensure precise positioning of oily sheets.
- Ideal for automated applications

P 2/63

VSA-VS BM

VSA-VS BM-SIF

VSBM



Suction Cups with Foam Ring Seals

- 2 standard materials
- Nitrile
- Silicone

- The foam ring is designed for gripping products with an uneven or ridged surface, e.g.
- Sawn wood, sheet metal, flat surfaces with bumps or hollows.
- All granular surfaces to which suction cups cannot adhere correctly and therefore cannot be airtight.
- Foam rings can be adapted to VSA and VS series.

P 2/65

VP

Flat Suction Cups Ø 8 to 75 mm



VP series flat suction cups are specially recommended for handling flat, rigid, smooth products.

- High tensile force
- High resistance to lateral forces enabling vertical handling.
- High degree of precision

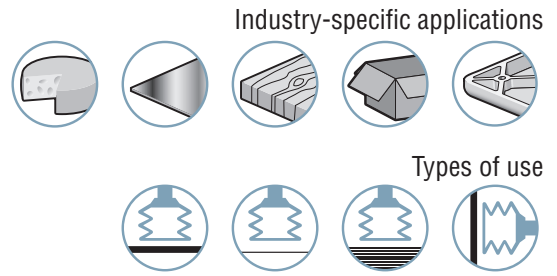

2
VP

Materials

- NBR** Nitrile
NR Natural rubber
SIT5 Translucent silicone
STN SITON®

Suction Cup Properties

	Ø (mm)	(cm ³)	(N) ⁽¹⁾	(N) ⁽¹⁾	(mm)	NBR	SIT5	NR	STN
VP 8	7.5	0.04	1.1	0.5	10	VP8NBR	VP8SIT5	-	VP8STN
VP 10	10	0.05	1.6	0.8	13	VP10NBR	VP10SIT5	-	-
VP 15	15	0.18	3.7	1.8	13	VP15NBR	VP15SIT5	-	VP15STN
VP 20	20	0.44	6.1	3.0	20	VP20NBR	VP20SIT5	-	VP20STN
VP 25	25	0.7	9.4	4.7	25	VP25NBR	VP25SIT5	-	VP25STN
VP 26	26	1.5	11.2	5.6	35	VP26NBR	VP26SIT5	-	-
VP 30	30	2.9	15.9	7.9	40	VP30NBR	VP30SIT5	-	VP30STN
VP 35	35	2.7	23.1	11.6	50	VP35NBR	VP35SIT5	-	-
VP 40	40	4	26.7	13.4	50	VP40NBR	VP40SIT5	VP40NR	VP40STN
VP 50	52	7	38.3	19.1	75	VP50NBR	VP50SIT5	-	VP50STN
VP 60	60	7.3	57.8	28.9	100	VP60NBR	VP60SIT5	-	-
VP 75	75	16	101.1	50.6	130	VP75NBR	VP75SIT5	VP75NR	-

(1) Actual force of the suction cup in use with 65% vacuum and including a safety factor of 2 for horizontal handling and a factor of 4 for vertical handling.

Choice of Fittings

(Ø)	Group	M5-M	M6-M	M8-M	M10-M	G1/8"-F	G1/8"-M	10/32-M	G1/4"-F	G1/4"-M	G3/8"-M	G1/2"-M
8...25	1	■	■	-	-	■	■	□	-	-	-	-
26...60	2	□	□	□	□	■	■	-	■	■	-	-
75	3	-	-	-	□	-	■	-	■	■	■	□

■ Standard available configurations (suction cup + fitting) refer to page 2/4
 □ Additional mounting configurations see page 2/7

Fitting: M = male F = female

Types of Assembly

COVAL suction cups can be assembled in a wide variety of configurations.

- C** **Version C:** Barbed fitting
- S** **Version S:** Factory-crimped fitting
- V** **Version V:** Removable fitting: (adapter and hollow screw)
- E** **Version E:** Pressed fitting







Please specify the part n°. e.g. VP40STNIM14C
 Refer to page 2/4



Accessories

To optimize the use of your suction cups, Coval offers a comprehensive range of accessories (feelers, nozzle fittings, spring extensions, and feeder systems, etc.), see chapters 4 and 14.



Group 1		C 			
Ø 8 - 25 mm	THREAD	M5-M	M6-M	G1/8"-M	G1/8"-F
	VP8NBR	VP8NBRIMM5C	VP8NBRIMM6C	VP8NBRIM18C	VP8NBRIF18C
	VP8SIT5	VP8SIT5IMM5C	VP8SIT5IMM6C	VP8SIT5IM18C	VP8SIT5IF18C
	VP8STN	VP8STNIMM5C	VP8STNIMM6C	VP8STNIM18C	VP8STNIF18C
	VP10NBR	VP10NBRIMM5C	VP10NBRIMM6C	VP10NBRIM18C	VP10NBRIF18C
	VP10SIT5	VP10SIT5IMM5C	VP10SIT5IMM6C	VP10SIT5IM18C	VP10SIT5IF18C
	VP15NBR	VP15NBRIMM5C	VP15NBRIMM6C	VP15NBRIM18C	VP15NBRIF18C
	VP15SIT5	VP15SIT5IMM5C	VP15SIT5IMM6C	VP15SIT5IM18C	VP15SIT5IF18C
	VP15STN	VP15STNIMM5C	VP15STNIMM6C	VP15STNIM18C	VP15STNIF18C
	VP20NBR	VP20NBRIMM5C	VP20NBRIMM6C	VP20NBRIM18C	VP20NBRIF18C
	VP20SIT5	VP20SIT5IMM5C	VP20SIT5IMM6C	VP20SIT5IM18C	VP20SIT5IF18C
	VP20STN	VP20STNIMM5C	VP20STNIMM6C	VP20STNIM18C	VP20STNIF18C
	VP25NBR	VP25NBRIMM5C	VP25NBRIMM6C	VP25NBRIM18C	VP25NBRIF18C
	VP25SIT5	VP25SIT5IMM5C	VP25SIT5IMM6C	VP25SIT5IM18C	VP25SIT5IF18C
VP25STN	VP25STNIMM5C	VP25STNIMM6C	VP25STNIM18C	VP25STNIF18C	

Group 2		C 		E 		V 			
Ø 26 - 60 mm	THREAD	G1/4"-M	G1/4"-F	G1/4"-M	G1/4"-F	G1/8"-M	G1/8"-F	G1/4"-M	G1/4"-F
	VP26NBR	VP26NBRIM14C	VP26NBRIF14C	VP26NBRIM14	VP26NBRIF14	VP26NBRIM18V	VP26NBRIF18V	VP26NBRIM14V	VP26NBRIF14V
	VP26SIT5	VP26SIT5IM14C	VP26SIT5IF14C	VP26SIT5IM14	VP26SIT5IF14	VP26SIT5IM18V	VP26SIT5IF18V	VP26SIT5IM14V	VP26SIT5IF14V
	VP30NBR	VP30NBRIM14C	VP30NBRIF14C	VP30NBRIM14	VP30NBRIF14	VP30NBRIM18V	VP30NBRIF18V	VP30NBRIM14V	VP30NBRIF14V
	VP30SIT5	VP30SIT5IM14C	VP30SIT5IF14C	VP30SIT5IM14	VP30SIT5IF14	VP30SIT5IM18V	VP30SIT5IF18V	VP30SIT5IM14V	VP30SIT5IF14V
	VP30STN	VP30STNIM14C	VP30STNIF14C	VP30STNIM14	VP30STNIF14	VP30STNIM18V	VP30STNIF18V	VP30STNIM14V	VP30STNIF14V
	VP35NBR	VP35NBRIM14C	VP35NBRIF14C	VP35NBRIM14	VP35NBRIF14	VP35NBRIM18V	VP35NBRIF18V	VP35NBRIM14V	VP35NBRIF14V
	VP35SIT5	VP35SIT5IM14C	VP35SIT5IF14C	VP35SIT5IM14	VP35SIT5IF14	VP35SIT5IM18V	VP35SIT5IF18V	VP35SIT5IM14V	VP35SIT5IF14V
	VP40NBR	VP40NBRIM14C	VP40NBRIF14C	VP40NBRIM14	VP40NBRIF14	VP40NBRIM18V	VP40NBRIF18V	VP40NBRIM14V	VP40NBRIF14V
	VP40NR	VP40NRIM14C	VP40NRIF14C	VP40NRIM14	VP40NRIF14	VP40NRIM18V	VP40NRIF18V	VP40NRIM14V	VP40NRIF14V
	VP40SIT5	VP40SIT5IM14C	VP40SIT5IF14C	VP40SIT5IM14	VP40SIT5IF14	VP40SIT5IM18V	VP40SIT5IF18V	VP40SIT5IM14V	VP40SIT5IF14V
	VP40STN	VP40STNIM14C	VP40STNIF14C	VP40STNIM14	VP40STNIF14	VP40STNIM18V	VP40STNIF18V	VP40STNIM14V	VP40STNIF14V
	VP50NBR	VP50NBRIM14C	VP50NBRIF14C	VP50NBRIM14	VP50NBRIF14	VP50NBRIM18V	VP50NBRIF18V	VP50NBRIM14V	VP50NBRIF14V
	VP50SIT5	VP50SIT5IM14C	VP50SIT5IF14C	VP50SIT5IM14	VP50SIT5IF14	VP50SIT5IM18V	VP50SIT5IF18V	VP50SIT5IM14V	VP50SIT5IF14V
	VP50STN	VP50STNIM14C	VP50STNIF14C	VP50STNIM14	VP50STNIF14	VP50STNIM18V	VP50STNIF18V	VP50STNIM14V	VP50STNIF14V
	VP60NBR	VP60NBRIM14C	VP60NBRIF14C	VP60NBRIM14	VP60NBRIF14	VP60NBRIM18V	VP60NBRIF18V	VP60NBRIM14V	VP60NBRIF14V
	VP60SIT5	VP60SIT5IM14C	VP60SIT5IF14C	VP60SIT5IM14	VP60SIT5IF14	VP60SIT5IM18V	VP60SIT5IF18V	VP60SIT5IM14V	VP60SIT5IF14V

Group 3		V 			S 		
Ø 75 mm	THREAD	G1/8"-M	G1/4"-M	G1/4"-F	G1/4"-M	G1/4"-F	G3/8"-M
	VP75NBR	VP75NBRIM18V	VP75NBRIM14V	VP75NBRIF14V	VP75NBRIM14	VP75NBRIF14	VP75NBRIM38
	VP75NR	VP75NRIM18V	VP75NRIM14V	VP75NRIF14V	VP75NRIM14	VP75NRIF14	VP75NRIM38
VP75SIT5	VP75SIT5IM18V	VP75SIT5IM14V	VP75SIT5IF14V	VP75SIT5IM14	VP75SIT5IF14	VP75SIT5IM38	

Additional mounting configurations are available (see page 2/7).
For standard configurations (suction cup+fitting), the C and V versions are delivered unassembled.

VP

Flat Suction Cups Ø 8 to 75 mm

Dimensions "Suction Cup + Fitting"



VP 2

VP 8 - 10 Group 1

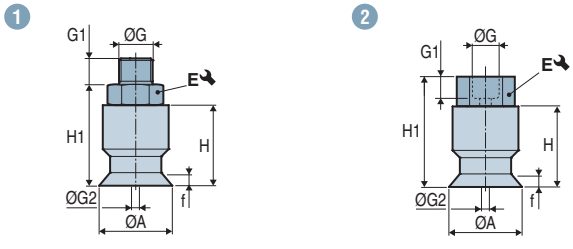

VP 15 - 25 Group 1

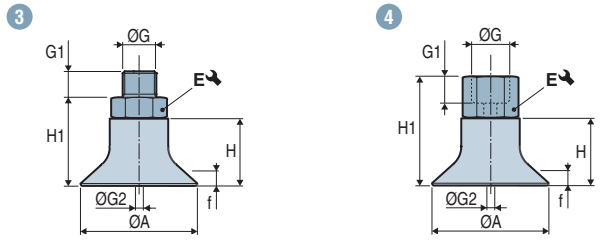

VP 26 - 60 Group 2

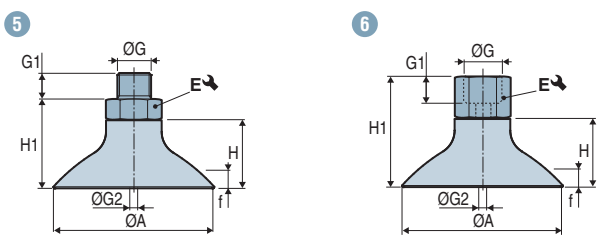

VP 75 Group 3

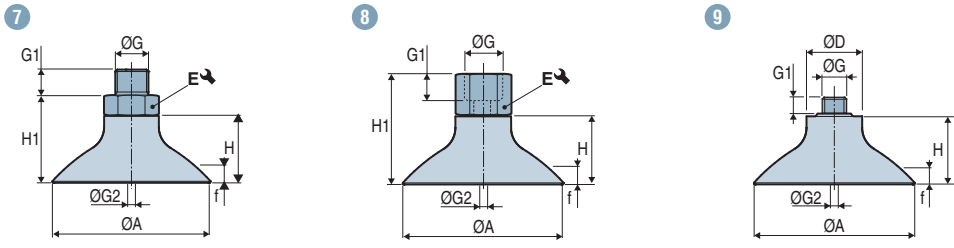

Group 1	Diagram	ØA	ØD	f ⁽¹⁾	H	H1	ØG	G1	ØG2 ⁽²⁾	E ↘	⊖ (g)	
Ø 8 - 25 mm	VP8---IMM5C	1	7.5	-	1.3	10	15	M5-M	4.5	2.5	7	3.5
	VP8---IMM6C	1	7.5	-	1.3	10	15	M6-M	5	3.5	7	3.1
	VP8---IM18C	1	7.5	-	1.3	10	16	G1/8"-M	7.5	3.5	14	4.5
	VP8---IF18C	2	7.5	-	1.3	10	22	G1/8"-F	8	3.5	14	4.4
	VP10---IMM5C	1	10	-	1.5	10.5	15.5	M5-M	4.5	2.5	7	3.6
	VP10---IMM6C	1	10	-	1.5	10.5	15.5	M6-M	5	3.5	7	3.2
	VP10---IM18C	1	10	-	1.5	10.5	16.5	G1/8"-M	7.5	3.5	14	4.6
	VP10---IF18C	2	10	-	1.5	10.5	22.5	G1/8"-F	8	3.5	14	4.5
	VP15---IMM5C	3	15	-	2.25	11	16	M5-M	4.5	2.5	7	3.8
	VP15---IMM6C	3	15	-	2.25	11	16	M6-M	5	3.5	7	3.4
	VP15---IM18C	3	15	-	2.25	11	17	G1/8"-M	7.5	3.5	14	4.8
	VP15---IF18C	4	15	-	2.25	11	23	G1/8"-F	8	3.5	14	4.7
	VP20---IMM5C	3	20	-	3	11.5	16.5	M5-M	4.5	2.5	7	4.2
	VP20---IMM6C	3	20	-	3	11.5	16.5	M6-M	5	3.5	7	3.8
	VP20---IM18C	3	20	-	3	11.5	17.5	G1/8"-M	7.5	3.5	14	5.2
	VP20---IF18C	4	20	-	3	11.5	23.5	G1/8"-F	8	3.5	14	5.1
	VP25---IMM5C	3	25	-	3	12	17	M5-M	4.5	2.5	7	4.6
	VP25---IMM6C	3	25	-	3	12	17	M6-M	5	3.5	7	4.2
	VP25---IM18C	3	25	-	3	12	18	G1/8"-M	7.5	3.5	14	5.6
	VP25---IF18C	4	25	-	3	12	24	G1/8"-F	8	3.5	14	5.5

Note: All dimensions are in mm

(1) f = Deflection of the suction cup. (2) Ø G2 = Ø internal orifice of the fitting.



Group 2	Diagram	ØA	ØD	f ⁽¹⁾	H	H1	ØG	G1	ØG2 ⁽²⁾	E ↘	⊞ (g)	
Ø 26 - 60 mm	VP26---IM18V	5	26	-	3	19.5	24	G1/8"-M	6	3.5	13	17.9
	VP26---IF18V	6	26	-	3	19.5	32.5	G1/8"-F	7.5	3.5	13	21.2
	VP26---IM14	5	26	-	3	19.5	23.5	G1/4"-M	11	4.4	17	11.6
	VP26---IM14C	5	26	-	3	19.5	27.5	G1/4"-M	10	7	17	12.5
	VP26---IM14V	5	26	-	3	19.5	24.5	G1/4"-M	8	3.5	17	27.2
	VP26---IF14	6	26	-	3	19.5	34.5	G1/4"-F	10	4.4	17	12.2
	VP26---IF14C	6	26	-	3	19.5	34.5	G1/4"-F	12	6.9	17	11.8
	VP26---IF14V	6	26	-	3	19.5	35.5	G1/4"-F	11	3.5	17	31.8
	VP30---IM18V	5	30	-	2.5	19	23.5	G1/8"-M	6	3.5	13	17.3
	VP30---IF18V	6	30	-	2.5	19	32	G1/8"-F	7.5	3.5	13	21.6
	VP30---IM14	5	30	-	2.5	19	23	G1/4"-M	11	4.4	17	12.0
	VP30---IM14C	5	30	-	2.5	19	27	G1/4"-M	10	7	17	12.9
	VP30---IM14V	5	30	-	2.5	19	24	G1/4"-M	8	3.5	17	27.6
	VP30---IF14	6	30	-	2.5	19	34	G1/4"-F	10	4.4	17	12.6
	VP30---IF14C	6	30	-	2.5	19	34	G1/4"-F	12	6.9	17	12.2
	VP30---IF14V	6	30	-	2.5	19	35	G1/4"-F	11	3.5	17	32.2
	VP35---IM18V	5	35	-	3	20	24.5	G1/8"-M	6	3.5	13	20.1
	VP35---IF18V	6	35	-	3	20	33	G1/8"-F	7.5	3.5	13	23.4
	VP35---IM14	5	35	-	3	20	24	G1/4"-M	11	4.4	17	13.8
	VP35---IM14C	5	35	-	3	20	28	G1/4"-M	10	7	17	14.7
	VP35---IM14V	5	35	-	3	20	25	G1/4"-M	8	3.5	17	29.4
	VP35---IF14	6	35	-	3	20	35	G1/4"-F	10	4.4	17	14.4
	VP35---IF14C	6	35	-	3	20	35	G1/4"-F	12	6.9	17	14.0
	VP35---IF14V	6	35	-	3	20	36	G1/4"-F	11	3.5	17	34.0
	VP40---IM18V	5	40	-	3	20	24.5	G1/8"-M	6	3.5	13	20.6
	VP40---IF18V	6	40	-	3	20	33	G1/8"-F	7.5	3.5	13	23.9
	VP40---IM14	5	40	-	3	20	24	G1/4"-M	11	4.4	17	14.3
	VP40---IM14C	5	40	-	3	20	28	G1/4"-M	10	7	17	15.2
	VP40---IM14V	5	40	-	3	20	25	G1/4"-M	8	3.5	17	29.9
	VP40---IF14	6	40	-	3	20	35	G1/4"-F	10	4.4	17	14.9
VP40---IF14C	6	40	-	3	20	35	G1/4"-F	12	6.9	17	14.5	
VP40---IF14V	6	40	-	3	20	36	G1/4"-F	11	3.5	17	34.5	
VP50---IM18V	5	52	-	4.5	22	26.5	G1/8"-M	6	3.5	13	26.4	
VP50---IF18V	6	52	-	4.5	22	35	G1/8"-F	7.5	3.5	13	29.7	
VP50---IM14	5	52	-	4.5	22	26	G1/4"-M	11	4.4	17	20.1	
VP50---IM14C	5	52	-	4.5	22	30	G1/4"-M	10	7	17	21.0	
VP50---IM14V	5	52	-	4.5	22	27	G1/4"-M	8	3.5	17	35.7	
VP50---IF14	6	52	-	4.5	22	37	G1/4"-F	10	4.4	17	20.7	
VP50---IF14C	6	52	-	4.5	22	37	G1/4"-F	12	6.9	17	20.3	
VP50---IF14V	6	52	-	4.5	22	38	G1/4"-F	11	3.5	17	40.3	
VP60---IM18V	5	60	-	4.5	22	26.5	G1/8"-M	6	3.5	13	30.1	
VP60---IF18V	6	60	-	4.5	22	35	G1/8"-F	7.5	3.5	13	33.4	
VP60---IM14	5	60	-	4.5	22	26	G1/4"-M	11	4.4	17	23.8	
VP60---IM14C	5	60	-	4.5	22	30	G1/4"-M	10	7	17	24.7	
VP60---IM14V	5	60	-	4.5	22	27	G1/4"-M	8	3.5	17	39.4	
VP60---IF14	6	60	-	4.5	22	37	G1/4"-F	10	4.4	17	24.4	
VP60---IF14C	6	60	-	4.5	22	37	G1/4"-F	12	6.9	17	24.0	
VP60---IF14V	6	60	-	4.5	22	38	G1/4"-F	11	3.5	17	44.0	

Group 3

Ø 75 mm	VP75---IM18V	9	75	23	4.5	32	-	G1/8"-M	8	6	-	58.3
	VP75---IM14	7	75	-	4.5	32	38	G1/4"-M	11	8	21	46.4
	VP75---IM14V	7	75	-	4.5	32	37	G1/4"-M	8	6	17	68.9
	VP75---IF14	8	75	-	4.5	32	47	G1/4"-F	10	8	21	50.3
	VP75---IF14V	8	75	-	4.5	32	51	G1/4"-F	9	6	17	78.5
	VP75---IM38	7	75	-	4.5	32	43	G3/8"-M	11	8	21	47

Note: All dimensions are in mm

(1) f = Deflection of the suction cup. (2) Ø G2 = Ø internal orifice of the fitting.



2
VP

VP 8 - 25 Group 1

Barbed fittings **C**

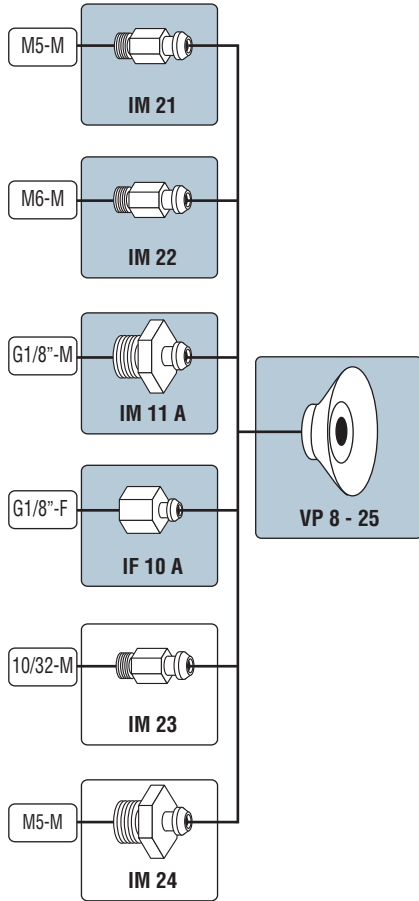

VP 26 - 60 Group 2

Barbed fittings **C**

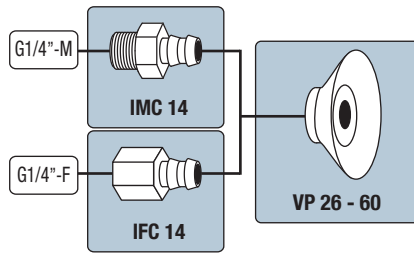

Pressed fittings **E**

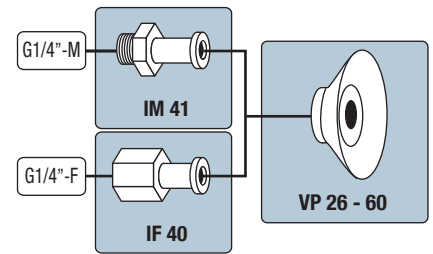

Adapters

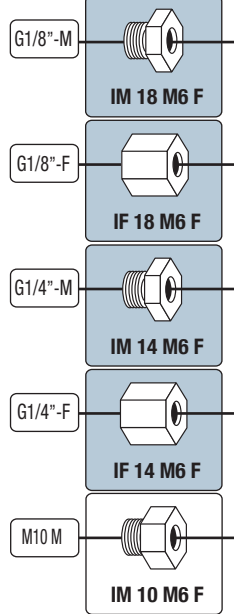

Removable fittings **V**

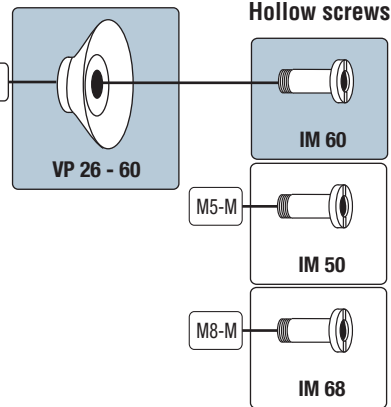

VP 75 Group 3

Factory-crimped fittings **S**

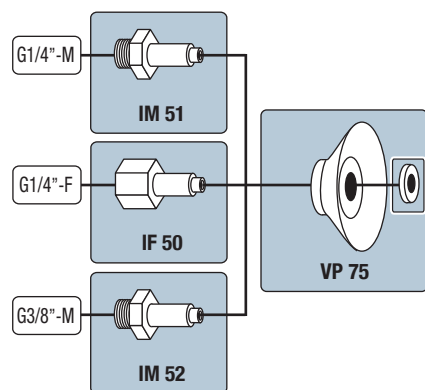

Removable fittings **V**

Adapters

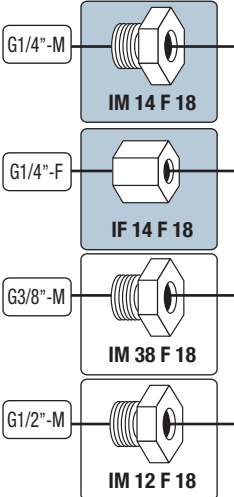

Hollow screws

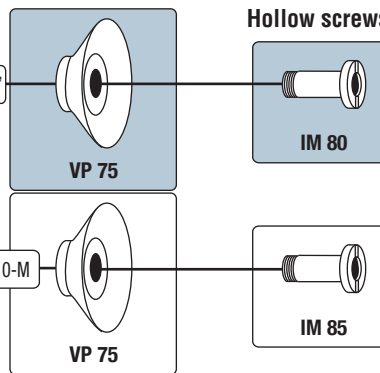

Configurations (suction cup + fitting) refer to page 2/4
 Non-standard configurations must be ordered in separate part numbers.

Fittings and suction cups dimensions: see page 2/8.



Suction Cups

VP 8... 10

VP 15... 25

VP 26... 75

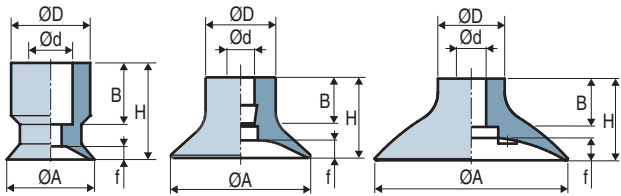

(1) f = Deflection of the suction cup.

VP	ØA	H	Ød	ØD	f (1)	B	⚖ (g)
VP 8	7.5	10	5	9	1.3	7	0.4
VP 10	10	10.5	4.4	9	1.5	7	0.5
VP 15	15	11	4	9	2.25	7	0.7
VP 20	20	11.5	4	10	3	7	1.2
VP 25	25	12	4	10	3	7	1.4
VP 26	26	19.5	8	16	3	13	3.7
VP 30	30	19	8	16	2.5	13	4
VP 35	35	20	8	16	3	13	5.6
VP 40	40	20	8	16	3	13	9
VP 50	52	22	8	18	4.5	13	14
VP 60	60	22	8	18	4.5	13	16
VP 75	75	32	12	23	4.5	20	33

Barbed Fittings

Male - IM

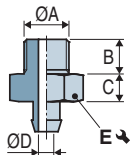

Female - IF

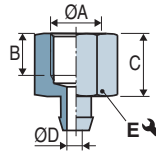

	ØA	B	C	ØD	E	Material	⚖ (g)
IM 11 A	G1/8"-M	7.5	6	3.5	14	Aluminum	4.1
IMC 14	G1/4"-M	10	8	7	17	Aluminum	8.7
IM 21 (2)	M5-M	4.5	5	2.5	7	Nickel-plated brass	3.1
IM 22 (2)	M6-M	5	5	3.5	7	Nickel-plated brass	2.7
IM 23	10/32-M	4.5	5	2.5	7	Brass	3
IM 24	M5-M	4.5	2.5	2.5	10	Nickel-plated brass	3.2
IF 10 A	G1/8"-F	8	12	3.5	14	Aluminum	4
IFC 14	G1/4"-F	12	15	6.9	17	Aluminum	8

Hollow Screws

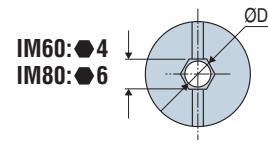
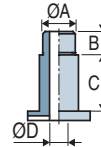

	ØA	B	C	ØD	Material	⚖ (g)
IM 50	M5-M	5	11	2.8	Brass	7.4
IM 60 (2) (3)	M6-M	7	11	3.5	Nickel-plated brass	7.5
IM 68	M8-M	8	11	5.2	Nickel-plated brass	6.4
IM 80	G1/8"-M	8	18	6	Nickel-plated brass	23.7
IM 85	M10x150-M	8	18	6	Nickel-plated brass	23.5

Factory-cripped Fittings

Male - IM

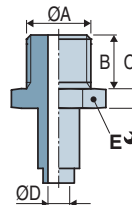

Female - IF

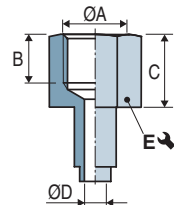

	ØA	B	C	ØD	E	Material	⚖ (g)
IM 51	G1/4"-M	11	6	4.4	17	Aluminum	11.8
IF 50	G1/4"-F	10	15	8	21	Aluminum	15.7
IM 52	G3/8"-M	11	6	8	21	Aluminum	14

Adapters for Hollow Screws

Male - IM

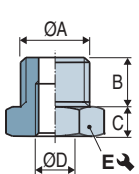

Female - IF

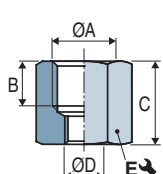

	ØA	B	C	ØD	E	Material	⚖ (g)
IM 10 M6F	M10-M	7	3.5	M6-F	13	Brass	5.9
IM 12 F18	G1/2"-M	14	6	G1/8"-F	22	Nickel-plated brass	46.8
IM 14 M6F	G1/4"-M	8	5	M6-F	17	Nickel-plated brass	15.9
IM 14 F18	G1/4"-M	8	5	G1/8"-F	17	Nickel-plated brass	10.6
IM 18 M6F	G1/8"-M	6	4.5	M6-F	13	Nickel-plated brass	6.6
IM 38 F18	G3/8"-M	9	5	G1/8"-F	19	Nickel-plated brass	18.8
IF 14 M6F	G1/4"-F	11	16	M6-F	17	Nickel-plated brass	20.5
IF 18 M6F	G1/8"-F	7.5	13	M6-F	13	Nickel-plated brass	9.9
IF 14 F18	G1/4"-F	9	19	G1/8"-F	17	Nickel-plated brass	20.2

The values represent the average characteristics of our products.

Note: All dimensions are in mm.

(2) Flow restrictor version available: orifice calibrated to reduce leaks when used with a multi-cup gripper (see page 4/10).

(3) Available in stainless steel.

Pressed Fitting

Male - IM

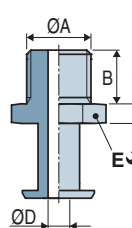

Female - IF

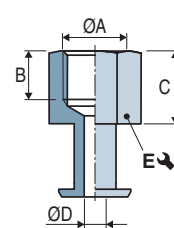

	ØA	B	C	ØD	E	Material	⚖ (g)
IM 41	G1/4"-M	11	4	4.4	17	Aluminum	7.8
IF 40	G1/4"-F	10	15	4.4	17	Aluminum	8.4

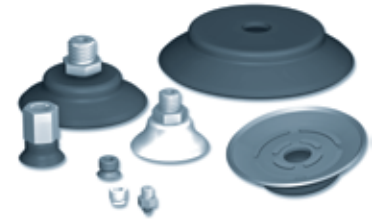

The profile of the VPG series extra-flat suction cups provides for accuracy in load gripping and speeds up throughput rates. These suction cups are used for flat surfaces only.

Materials

NBR Nitrile
SI Silicone
STN SITON®

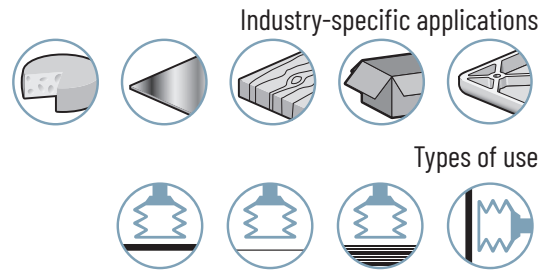

2

VPG

Suction Cup Properties

	Ø (mm)	V (cm ³)	F (N) ⁽¹⁾	F (N) ⁽¹⁾	R_{min} (mm)	NBR	SI	STN
VPG 2	2	0.00073	0.1	0.04	2	VPG2NBR	VPG2SI	-
VPG 3.5	3.5	0.0022	0.2	0.1	8	VPG3.5NBR	VPG3.5SI	-
VPG 5	5	0.005	0.5	0.2	8	VPG5NBR	VPG5SI	VPG5STN
VPG 6	6	0.008	0.7	0.4	8	VPG6NBR	VPG6SI	VPG6STN
VPG 8	8	0.03	1.2	0.6	10	VPG8NBR	VPG8SI	VPG8STN
VPG 10	10	0.07	2.0	1.0	13	VPG10NBR	VPG10SI	VPG10STN
VPG 15	15	0.2	4.7	2.4	13	VPG15NBR	VPG15SI	VPG15STN
VPG 20	20	0.5	8.8	4.4	20	VPG20NBR	VPG20SI	VPG20STN
VPG 25	25	1.1	12.1	6.1	25	VPG25NBR	VPG25SI	VPG25STN
VPG 30	30	1.4	16.4	8.2	40	VPG30NBR	VPG30SI	VPG30STN
VPG 35	35	2.9	23.8	11.9	50	VPG35NBR	VPG35SI	-
VPG 40	40	3.8	34.7	17.3	50	VPG40NBR	VPG40SI	VPG40STN
VPG 50	50	5.3	54.2	27.1	75	VPG50NBR	VPG50SI	VPG50STN
VPG 60	60	12	88.8	44.4	100	VPG60NBR	VPG60SI	VPG60STN
VPG 60S	60	12	88.8	44.4	100	VPG60SNBR	VPG60SSI	VPG60SSTN
VPG 80	80	26.9	143.0	71.5	150	VPG80NBR	VPG80SI	VPG80STN
VPG 80S	80	26.9	143.0	71.5	150	VPG80SNBR	VPG80SSI	VPG80SSTN
VPG 95	95	41	202.2	101.1	200	VPG95NBR	VPG95SI	VPG95STN
VPG 95S	95	41	202.2	101.1	200	VPG95SNBR	VPG95SSI	VPG95SSTN
VPG 120	120	141	263.6	131.8	365	VPG120NBR	VPG120SI	VPG120STN
VPG 150	150	230	426.1	213.1	380	VPG150NBR	VPG150SI	VPG150STN
VPG 200	200	384	758.3	379.2	430	VPG200NBR	VPG200SI	VPG200STN

(1) Actual force of the suction cup in use with 65% vacuum and including a safety factor of 2 for horizontal handling and a factor of 4 for vertical handling.

Choice of Fittings

	M3-M	M5-M	M5-F	M6-M	M8-M	M10-M	M10x125-F	G1/8"-F	G1/8"-M	G1/4"-F	G1/4"-M	G1/2"-F
2, 3.5	■	■	-	-	-	-	-	-	-	-	-	-
5... 10	-	■	■	-	-	-	-	■	■	-	-	-
15, 20	-	■	-	-	-	-	-	■	■	-	-	-
25... 50	-	-	-	■	□	□	-	■	■	■	■	-
60... 95	-	-	-	-	-	-	■	-	-	■	■	-
60S... 95S	-	-	-	-	-	-	-	-	-	■	-	-
120... 200	-	-	-	-	-	-	-	-	-	-	-	■

■ Standard available configurations (suction cup + fitting)
 see page reference 2/10

□ Additional mounting configurations
 See pages 2/13 - 2/14

Fitting: M = male F = female

Types of Assembly

COVAL suction cups can be assembled in a wide variety of configurations.

C **Version C** : Barbed fitting

V **Version V** : Removable fitting:
 (adapter and hollow screw)

E **Version E** : Pressed fitting

Accessories

To optimize the use of your suction cups, Coval offers a comprehensive range of accessories (nozzle fittings, spring extensions, and feeder systems, etc.), see chapters 4 and 14.

Please specify the part n°. e.g. VPG25STNIF18C
 Refer to page 2/10

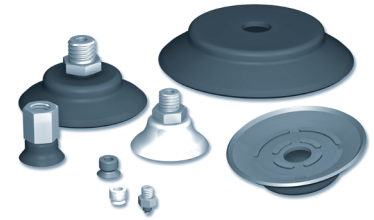

Ø 2 - 10 mm	THREAD	M3-M	M5-M	M5-F	G1/8"-M	G1/8"-F
	VPG2NBR	VPG2NBRIMM3C	VPG2NBRIMM5C	-	-	-
VPG2SI	VPG2SIIMM3C	VPG2SIIMM5C	-	-	-	
VPG3.5NBR	VPG3.5NBRIMM3C	VPG3.5NBRIMM5C	-	-	-	
VPG3.5SI	VPG3.5SIIMM3C	VPG3.5SIIMM5C	-	-	-	
VPG5NBR	-	VPG5NBRIMM5C	VPG5NBRIFM5C	VPG5NBRIM18C	VPG5NBRIF18C	
VPG5SI	-	VPG5SIIMM5C	VPG5SIIFM5C	VPG5SIIM18C	VPG5SIIF18C	
VPG5STN	-	VPG5STNIMM5C	VPG5STNIFM5C	VPG5STNIM18C	VPG5STNIF18C	
VPG6NBR	-	VPG6NBRIMM5C	VPG6NBRIFM5C	VPG6NBRIM18C	VPG6NBRIF18C	
VPG6SI	-	VPG6SIIMM5C	VPG6SIIFM5C	VPG6SIIM18C	VPG6SIIF18C	
VPG6STN	-	VPG6STNIMM5C	VPG6STNIFM5C	VPG6STNIM18C	VPG6STNIF18C	
VPG8NBR	-	VPG8NBRIMM5C	VPG8NBRIFM5C	VPG8NBRIM18C	VPG8NBRIF18C	
VPG8SI	-	VPG8SIIMM5C	VPG8SIIFM5C	VPG8SIIM18C	VPG8SIIF18C	
VPG8STN	-	VPG8STNIMM5C	VPG8STNIFM5C	VPG8STNIM18C	VPG8STNIF18C	
VPG10NBR	-	VPG10NBRIMM5C	VPG10NBRIFM5C	VPG10NBRIM18C	VPG10NBRIF18C	
VPG10SI	-	VPG10SIIMM5C	VPG10SIIFM5C	VPG10SIIM18C	VPG10SIIF18C	
VPG10STN	-	VPG10STNIMM5C	VPG10STNIFM5C	VPG10STNIM18C	VPG10STNIF18C	

Ø 15 - 20 mm	THREAD	G1/8"-M	G1/8"-F	M5-M	G1/8"-M	G1/8"-F
	VPG15NBR	VPG15NBRIM18C	VPG15NBRIF18C	VPG15NBRIMM5V	VPG15NBRIM18V	VPG15NBRIF18V
VPG15SI	VPG15SIIM18C	VPG15SIIF18C	VPG15SIIMM5V	VPG15SIIM18V	VPG15SIIF18V	
VPG15STN	VPG15STNIM18C	VPG15STNIF18C	VPG15STNIMM5V	VPG15STNIM18V	VPG15STNIF18V	
VPG20NBR	-	-	VPG20NBRIMM5V	VPG20NBRIM18V	VPG20NBRIF18V	
VPG20SI	-	-	VPG20SIIMM5V	VPG20SIIM18V	VPG20SIIF18V	
VPG20STN	-	-	VPG20STNIMM5V	VPG20STNIM18V	VPG20STNIF18V	

Ø 25 - 50 mm	THREAD	G1/8"-M	G1/8"-F	M6-M	G1/8"-M	G1/8"-F	G1/4"-M	G1/4"-F
	VPG25NBR	VPG25NBRIM18	VPG25NBRIF18	VPG25NBRIMM6V	VPG25NBRIM18V	VPG25NBRIF18V	VPG25NBRIM14V	VPG25NBRIF14V
VPG25SI	VPG25SIIM18	VPG25SIIF18	VPG25SIIMM6V	VPG25SIIM18V	VPG25SIIF18V	VPG25SIIM14V	VPG25SIIF14V	
VPG25STN	VPG25STNIM18	VPG25STNIF18	VPG25STNIMM6V	VPG25STNIM18V	VPG25STNIF18V	VPG25STNIM14V	VPG25STNIF14V	
VPG30NBR	VPG30NBRIM18	VPG30NBRIF18	VPG30NBRIMM6V	VPG30NBRIM18V	VPG30NBRIF18V	VPG30NBRIM14V	VPG30NBRIF14V	
VPG30SI	VPG30SIIM18	VPG30SIIF18	VPG30SIIMM6V	VPG30SIIM18V	VPG30SIIF18V	VPG30SIIM14V	VPG30SIIF14V	
VPG30STN	VPG30STNIM18	VPG30STNIF18	VPG30STNIMM6V	VPG30STNIM18V	VPG30STNIF18V	VPG30STNIM14V	VPG30STNIF14V	
VPG35NBR	VPG35NBRIM18	VPG35NBRIF18	VPG35NBRIMM6V	VPG35NBRIM18V	VPG35NBRIF18V	VPG35NBRIM14V	VPG35NBRIF14V	
VPG35SI	VPG35SIIM18	VPG35SIIF18	VPG35SIIMM6V	VPG35SIIM18V	VPG35SIIF18V	VPG35SIIM14V	VPG35SIIF14V	
VPG40NBR	VPG40NBRIM18	VPG40NBRIF18	VPG40NBRIMM6V	VPG40NBRIM18V	VPG40NBRIF18V	VPG40NBRIM14V	VPG40NBRIF14V	
VPG40SI	VPG40SIIM18	VPG40SIIF18	VPG40SIIMM6V	VPG40SIIM18V	VPG40SIIF18V	VPG40SIIM14V	VPG40SIIF14V	
VPG40STN	VPG40STNIM18	VPG40STNIF18	VPG40STNIMM6V	VPG40STNIM18V	VPG40STNIF18V	VPG40STNIM14V	VPG40STNIF14V	
VPG50NBR	-	-	VPG50NBRIMM6V	VPG50NBRIM18V	VPG50NBRIF18V	VPG50NBRIM14V	VPG50NBRIF14V	
VPG50SI	-	-	VPG50SIIMM6V	VPG50SIIM18V	VPG50SIIF18V	VPG50SIIM14V	VPG50SIIF14V	
VPG50STN	-	-	VPG50STNIMM6V	VPG50STNIM18V	VPG50STNIF18V	VPG50STNIM14V	VPG50STNIF14V	

Ø 60 - 95 mm	THREAD	M10x125-F	G1/4"-F	G1/4"-M	G1/4"-F
	VPG60NBR	VPG60NBR	-	VPG60NBRIM14V	VPG60NBRIF14V
VPG60SNBR	-	VPG60SNBR	-	-	
VPG60SI	VPG60SI	-	VPG60SIIM14V	VPG60SIIF14V	
VPG60SSI	-	VPG60SSI	-	-	
VPG60STN	VPG60STN	-	VPG60STNIM14V	VPG60STNIF14V	
VPG60SSTN	-	VPG60SSTN	-	-	
VPG80NBR	VPG80NBR	-	VPG80NBRIM14V	VPG80NBRIF14V	
VPG80SNBR	-	VPG80SNBR	-	-	
VPG80SI	VPG80SI	-	VPG80SIIM14V	VPG80SIIF14V	
VPG80SSI	-	VPG80SSI	-	-	
VPG80STN	VPG80STN	-	VPG80STNIM14V	VPG80STNIF14V	
VPG80SSTN	-	VPG80SSTN	-	-	
VPG95NBR	VPG95NBR	-	VPG95NBRIM14V	VPG95NBRIF14V	
VPG95SNBR	-	VPG95SNBR	-	-	
VPG95SI	VPG95SI	-	VPG95SIIM14V	VPG95SIIF14V	
VPG95SSI	-	VPG95SSI	-	-	
VPG95STN	VPG95STN	-	VPG95STNIM14V	VPG95STNIF14V	
VPG95SSTN	-	VPG95SSTN	-	-	

Ø 120 - 200 mm	THREAD	G1/2"-F *	G1/2"-F **
	VPG120NBR	VPG120NBRIF12V	VPG120NBRIF12V
VPG120SI	VPG120SIIF12V	VPG120SIIF12V	
VPG120STN	VPG120STNIF12V	VPG120STNIF12V	
VPG150NBR	VPG150NBRIF12V	VPG150NBRIF12V	
VPG150SI	VPG150SIIF12V	VPG150SIIF12V	
VPG150STN	VPG150STNIF12V	VPG150STNIF12V	
VPG200NBR	VPG200NBRIF12V	VPG200NBRIF12V	
VPG200SI	VPG200SIIF12V	VPG200SIIF12V	
VPG200STN	VPG200STNIF12V	VPG200STNIF12V	

*Configured using fitting n° IFS12120
 ** Configured using fitting n° IF12120

Non-standard configurations are available (see page 2/13 and 2/14). For standard configurations (suction cup+fitting), the C and V versions are delivered unassembled.

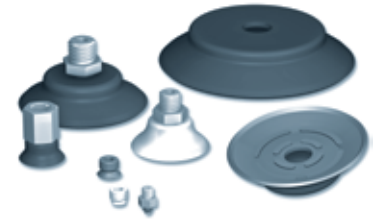

VPG 2 - 10

VPG 15 - 50

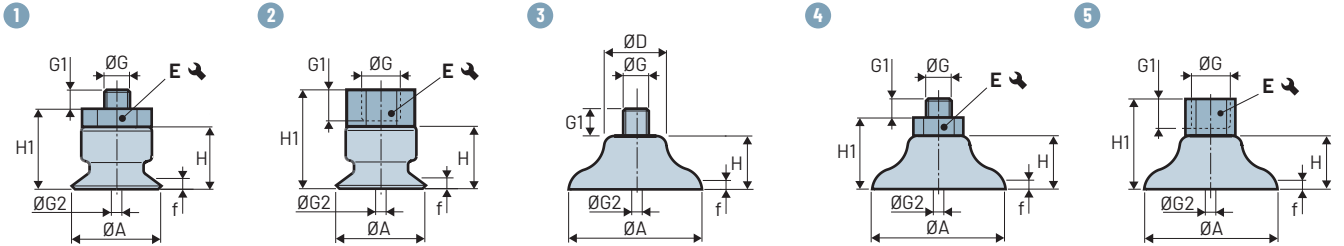

VPG 60 - 95

VPG 120 - 200

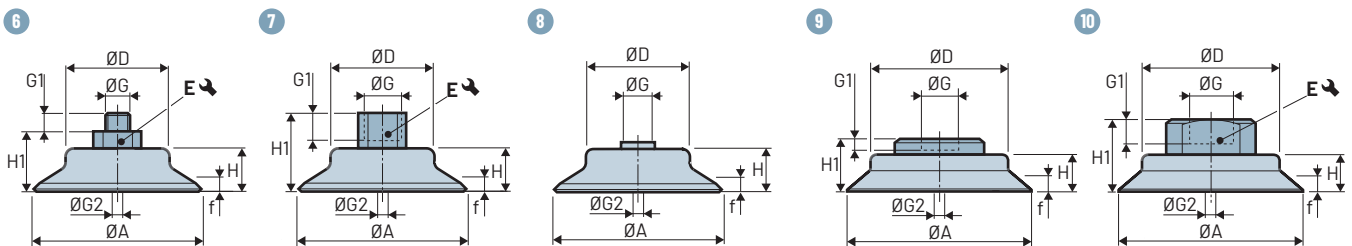

	Diagram	Ø A	Ø D	f ⁽¹⁾	H	H1	Ø G	G1	Ø G2 ⁽²⁾	E ↺	⚖ (g)	
Ø 2 - 10 mm	VPG2---IMM3C	1	2	-	0.5	4	6	M3-M	3	1	5	0.21
	VPG2---IMM5C	1	2	-	0.5	4	7.5	M5-M	4.5	1	7	0.91
	VPG3.5---IMM3C	1	3.5	-	0.5	4	6	M3-M	3	1	5	0.22
	VPG3.5---IMM5C	1	3.5	-	0.5	4	7.5	M5-M	4.5	1	7	0.65
	VPG5---IMM5C	1	5	-	0.8	6.5	10	M5-M	4.5	2.2	7	0.86
	VPG5---IFM5C	2	5	-	0.8	6.5	15.5	M5-F	6	2.2	8	1.3
	VPG5---IM18C	1	5	-	0.8	6.5	11.5	G1/8"-M	8	2.2	14	4.1
	VPG5---IF18C	2	5	-	0.8	6.5	21.5	G1/8"-F	9	2.2	14	5.3
	VPG6---IMM5C	1	6	-	0.8	6.5	10	M5-M	4.5	2.2	7	0.9
	VPG6---IFM5C	2	6	-	0.8	6.5	15.5	M5-F	6	2.2	8	1.3
	VPG6---IM18C	1	6	-	0.8	6.5	11.5	G1/8"-M	8	2.2	14	4.1
	VPG6---IF18C	2	6	-	0.8	6.5	21.5	G1/8"-F	9	2.2	14	5.3
	VPG8---IMM5C	1	8	-	1.2	7	10.5	M5-M	4.5	2.2	7	0.9
	VPG8---IFM5C	2	8	-	1.2	7	16	M5-F	6	2.2	8	1.4
	VPG8---IM18C	1	8	-	1.2	7	12	G1/8"-M	8	2.2	14	4.1
	VPG8---IF18C	2	8	-	1.2	7	22	G1/8"-F	9	2.2	14	5.33
VPG10---IMM5C	1	10	-	1.5	7.5	11	M5-M	4.5	2.2	7	1	
VPG10---IFM5C	2	10	-	1.5	7.5	16.5	M5-F	6	2.2	8	1.5	
VPG10---IM18C	1	10	-	1.5	7.5	12.5	G1/8"-M	8	2.2	14	4.2	
VPG10---IF18C	2	10	-	1.5	7.5	21.5	G1/8"-F	9	2.2	14	5.4	
Ø 15 - 20 mm	VPG15---IM18C	4	15	-	1.9	8	13	G1/8"-M	8	2.2	14	4.7
	VPG15---IF18C	5	15	-	1.9	8	23	G1/8"-F	9	2.5	14	5.9
	VPG15---IMM5V	3	15	-	1.9	8	-	M5-M	5	2.5	-	2
	VPG15---IM18V	4	15	-	1.9	8	12.5	G1/8"-M	6	2.5	13	9.3
	VPG15---IF18V	5	15	-	1.9	8	21	G1/8"-F	7.5	2.5	13	12.5
	VPG20---IMM5V	3	20	-	2.3	10	-	M5-M	5	2.5	-	3.7
	VPG20---IM18V	4	20	-	2.3	10	14.5	G1/8"-M	6	2.5	13	11
	VPG20---IF18V	5	20	-	2.3	10	23	G1/8"-F	7.5	2.5	13	14.2

Note: All dimensions are in mm.

(1) f = Deflection of the suction cup. (2) Ø G2 = Ø internal orifice of the fitting.

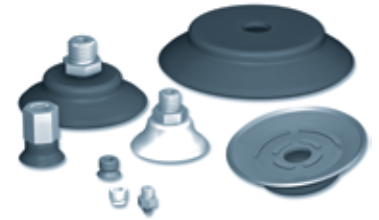
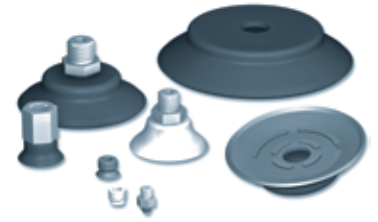

	Diagram	Ø A	Ø D	f ⁽¹⁾	H	H1	Ø G	G1	Ø G2 ⁽²⁾	E ↘	⚖ (g)	
Ø 25 - 50 mm	VPG25---IM18	4	25	-	3	14	G1/8"-M	8	4	14	6.9	
	VPG25---IF18	5	25	-	3	14	G1/8"-F	9	4	14	7.9	
	VPG25---IMM6V	3	25	-	3	14	-	M6-M	6	3.5	-	5.5
	VPG25---IM18V	4	25	-	3	14	18.5	G1/8"-M	6	3.5	13	12.1
	VPG25---IF18V	5	25	-	3	14	27	G1/8"-F	7.5	3.5	13	15.4
	VPG25---IM14V	4	25	-	3	14	19	G1/4"-M	8	3.5	17	21.4
	VPG25---IF14V	5	25	-	3	14	30	G1/4"-F	11	3.5	17	26
	VPG30---IM18	4	30	-	2	12	17	G1/8"-M	8	4	14	7.4
	VPG30---IF18	5	30	-	2	12	27	G1/8"-F	9	4	14	8.4
	VPG30---IMM6V	3	30	-	2	12	-	M6-M	6	3.5	-	6
	VPG30---IM18V	4	30	-	2	12	16.5	G1/8"-M	6	3.5	13	12.6
	VPG30---IF18V	5	30	-	2	12	25	G1/8"-F	7.5	3.5	13	15.9
	VPG30---IM14V	4	30	-	2	12	17	G1/4"-M	8	3.5	17	21.9
	VPG30---IF14V	5	30	-	2	12	28	G1/4"-F	11	3.5	17	26.5
	VPG35---IM18	4	35	-	3	14	19	G1/8"-M	8	4	14	9.9
	VPG35---IF18	5	35	-	3	14	29	G1/8"-F	9	4	14	10.9
	VPG35---IMM6V	3	35	-	3	14	-	M6-M	6	3.5	-	8.5
	VPG35---IM18V	4	35	-	3	14	18.5	G1/8"-M	6	3.5	13	15.1
	VPG35---IF18V	5	35	-	3	14	27	G1/8"-F	7.5	3.5	13	18.4
	VPG35---IM14V	4	35	-	3	14	19	G1/4"-M	8	3.5	17	24.4
	VPG35---IF14V	5	35	-	3	14	30	G1/4"-F	11	3.5	17	29
	VPG40---IM18	4	40	-	3.5	14	19	G1/8"-M	8	4	14	11.4
	VPG40---IF18	5	40	-	3.5	14	29	G1/8"-F	9	4	14	12.4
	VPG40---IMM6V	3	40	-	3.5	14	-	M6-M	6	3.5	-	10
	VPG40---IM18V	4	40	-	3.5	14	18.5	G1/8"-M	6	3.5	13	16.6
	VPG40---IF18V	5	40	-	3.5	14	27	G1/8"-F	7.5	3.5	13	19.9
	VPG40---IM14V	4	40	-	3.5	14	19	G1/4"-M	8	3.5	17	25.9
	VPG40---IF14V	5	40	-	3.5	14	30	G1/4"-F	11	3.5	17	30.5
	VPG50---IMM6V	3	50	-	4	15	-	M6-M	6	3.5	-	18.6
	VPG50---IM18V	4	50	-	4	15	19.5	G1/8"-M	6	3.5	13	25.2
VPG50---IF18V	5	50	-	4	15	28	G1/8"-F	7.5	3.5	13	28.5	
VPG50---IM14V	4	50	-	4	15	20	G1/4"-M	8	3.5	17	34.5	
VPG50---IF14V	5	50	-	4	15	31	G1/4"-F	11	3.5	17	39.1	
Ø 60 - 95 mm	VPG60---	8	60	38	5	16	-	M10x125-F	-	-	-	25.4
	VPG60---IM14V	6	60	38	5	16	21	G1/4"-M	10	5	17	32.4
	VPG60---IF14V	7	60	38	5	16	33	G1/4"-F	10	5	17	33.7
	VPG60S---	8	60	38	5	16	-	G1/4"-F	-	-	-	25.4
	VPG80---	8	80	53	6	18	-	M10x125-F	-	-	-	53
	VPG80---IM14V	6	80	53	6	18	23	G1/4"-M	10	5	17	60
	VPG80---IF14V	7	80	53	6	18	35	G1/4"-F	10	5	17	61.3
	VPG80S---	8	80	53	6	18	-	G1/4"-F	-	-	-	53
	VPG95---	8	95	68	6	19	-	M10x125-F	-	-	-	93.2
	VPG95---IM14V	6	95	68	6	19	24	G1/4"-M	10	5	17	100.2
VPG95---IF14V	7	95	68	6	19	36	G1/4"-F	10	5	17	101.5	
VPG95S---	8	95	68	6	19	-	G1/4"-F	-	-	-	93.2	
Ø 120 - 200 mm	VPG120---IF12V	10	120	89.5	6	24.5	54.5	G1/2"-F	24	19	48	454.8
	VPG120---IFS12V	9	120	89.5	6	24.5	37.5	G1/2"-F	13	-	-	373.5
	VPG150---IF12V	10	150	105	9	30.5	60.5	G1/2"-F	24	19	48	624.8
	VPG150---IFS12V	9	150	105	9	30.5	43.5	G1/2"-F	13	-	-	543.5
	VPG200---IF12V	10	200	143	12.5	35.5	65.5	G1/2"-F	24	19	48	914.8
	VPG200---IFS12V	9	200	143	12.5	35.5	48.5	G1/2"-F	13	-	-	833.5

Note: All dimensions are in mm.

(1) f = Deflection of the suction cup. (2) Ø G2 = Ø internal orifice of the fitting.



VPG 2 - 10

Barbed fittings  

2
VPG

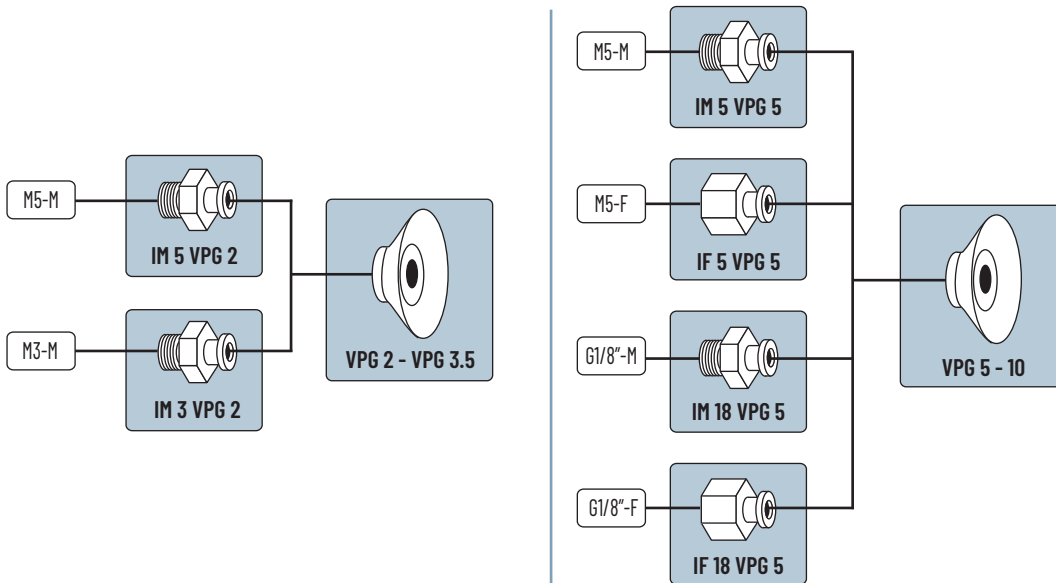

VPG 15 - 20

Barbed fittings  

Removable fittings  

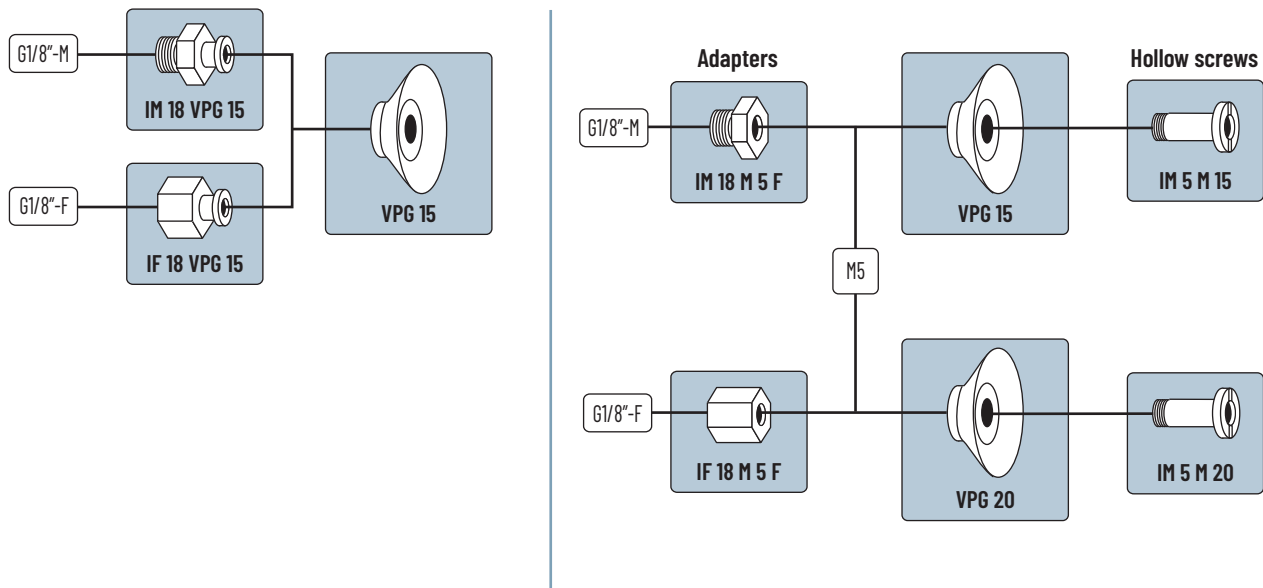

 Configurations (suction cup + fitting) refer to page 2/10

Fittings and suction cups dimensions: see page 2/15 and 2/16.

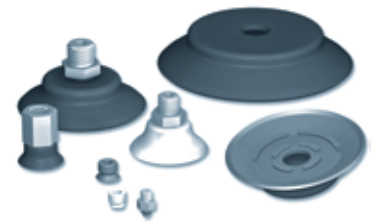

VPG 25 - 50

Pressed fittings



Removable fittings

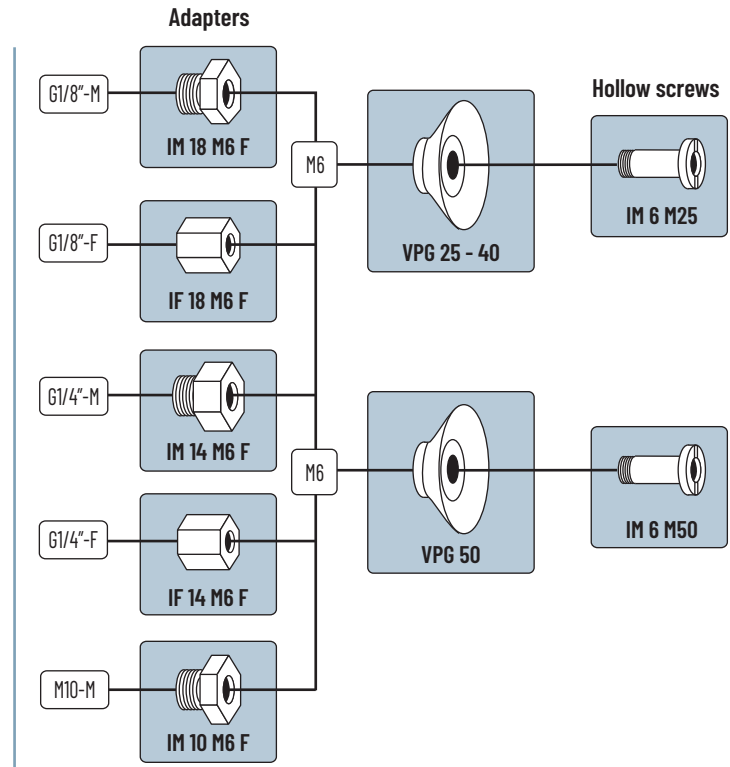
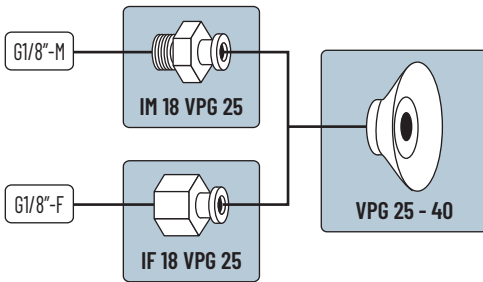

VPG 60 - 95

Removable fittings

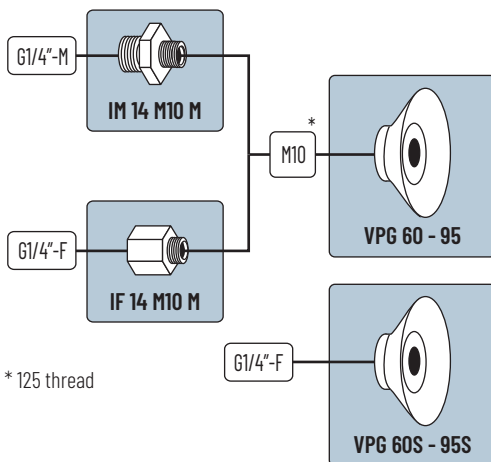

* 125 thread

VPG 120 - 200

Removable fittings

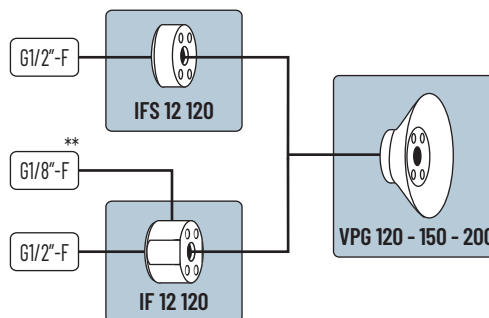

** Female auxiliary radial output

Configurations (suction cup + fitting) refer to page 2/10.

Fittings and suction cups dimensions: see page 2/15 and 2/16.

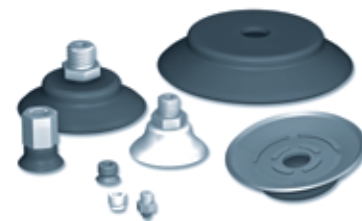

VPG 2 - 10

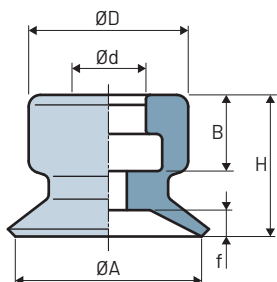

VPG 15 - 50

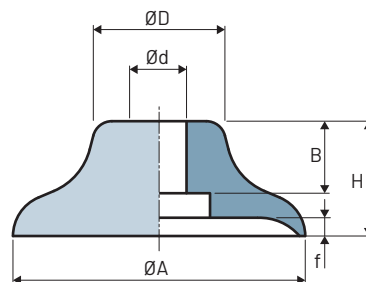

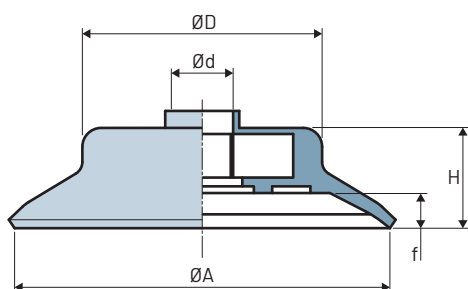

VPG 60 - 95

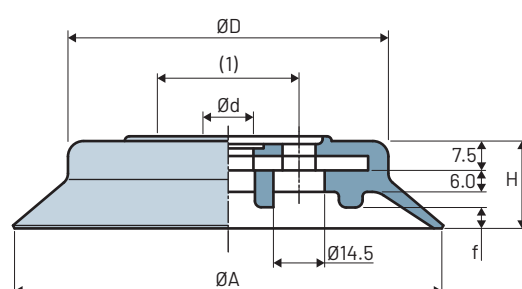

VPG 120 - 200



(1) 4 holes Ø 9 on Ø 40

 (Ø)	ØA	H	Ød	ØD	f ⁽¹⁾	B	 (g)
VPG 2	2	4	2	4	0.5	2.5	0.03
VPG 3.5	3.5	4	2	4	0.5	2.5	0.04
VPG 5	5	6.5	4	7.5	0.8	4	0.16
VPG 6	6	6.5	4	7.5	0.8	4	0.17
VPG 8	8	7	4	8	1.2	4	0.23
VPG 10	10	7.5	4	8.7	1.5	4	0.3
VPG 15	15	8	4.5	12	1.9	2.5	0.7
VPG 20	20	10	4.5	15	2.3	4.5	1.5
VPG 25	25	14	6	16	3	7	2.8
VPG 30	30	12	6	15	2	7	3.3
VPG 35	35	14	6	20.5	3	7	5.8
VPG 40	40	14	6	23.5	3.5	7	7.3
VPG 50	50	15	8	29	4	7	11.1
VPG 60	60	16	M10x125-F	38	5	-	25.4
VPG 60S	60	16	G1/4"-F	38	5	-	25.4
VPG 80	80	18	M10x125-F	53	6	-	53
VPG 80S	80	18	G1/4"-F	53	6	-	53
VPG 95	95	19	M10x125-F	68	6	-	93.2
VPG 95S	95	19	G1/4"-F	68	6	-	93.2
VPG 120	120	24.5	14.5	89.5	6	-	230
VPG 150	150	30.5	13	105	9	-	400
VPG 200	200	35.5	13	143	12.5	-	690

The values represent the average characteristics of our products.
Note: All dimensions are in mm.

(1) f = Deflection of the suction cup.

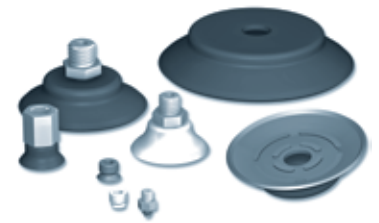

Barbed Fittings

Male - IM

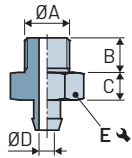

Female - IF

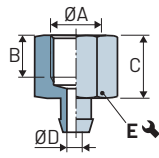

	Ø A	B	C	Ø D	E ↘	Material	⚖ (g)
IM 3 VPG2	M3-M	3	2	1	5	Aluminum	0.18
IM 5 VPG2	M5-M	4.5	3.5	1	7	Aluminum	0.61
IM 5 VPG5	M5-M	4.5	3.5	2.2	7	Aluminum	0.7
IM 18 VPG5	G1/8"-M	8	5	2.2	14	Aluminum	3.9
IM 18 VPG15	G1/8"-M	8	5	2.2	14	Aluminum	4
IF 5 VPG5	M5-F	6	9	2.2	8	Aluminum	1.2
IF 18 VPG5	G1/8"-F	9	15	2.2	14	Aluminum	5.1
IF 18 VPG15	G1/8"-F	9	15	2.5	14	Aluminum	5.2

Pressed Fittings

Male - IM

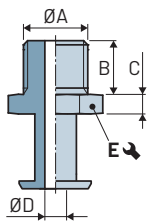

Female - IF

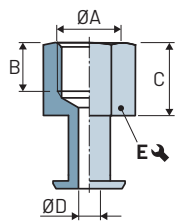

	Ø A	B	C	Ø D	E ↘	Material	⚖ (g)
IM 18 VPG25	G1/8"-M	8	5	4	14	Aluminum	4.08
IF 18 VPG25	G1/8"-F	9	15	4	14	Aluminum	5.5

Hollow Screws

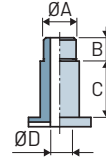

	Ø A	B	C	Ø D	Material	⚖ (g)
IM 5 M15	M5-M	5	2	2.5	Nickel-plated brass	1.3
IM 5 M20	M5-M	5	4	2.5	Nickel-plated brass	2.2
IM 6 M25	M6-M	6	6	3.5	Nickel-plated brass	2.7
IM 6 M50	M6-M	6	6	3.5	Nickel-plated brass	7.5

Adapters for Hollow Screws

Male - IM

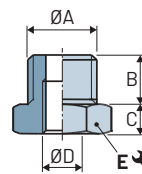

Female - IF

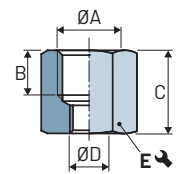

	Ø A	B	C	Ø D	E ↘	Material	⚖ (g)
IM 10 M6F	M10-M	7	3.5	M6-F	13	Brass	5.9
IM 14 M6F	G1/4"-M	8	5	M6-F	17	Nickel-plated brass	15.9
IM 18 M5F	G1/8"-M	6	4.5	M5-F	13	Nickel-plated brass	7.3
IM 18 M6F	G1/8"-M	6	4.5	M6-F	13	Nickel-plated brass	6.6
IF 14 M6F	G1/4"-F	11	16	M6-F	17	Nickel-plated brass	20.5
IF 18 M5F	G1/8"-F	7.5	13	M5-F	13	Nickel-plated brass	10.5
IF 18 M6F	G1/8"-F	7.5	13	M6-F	13	Nickel-plated brass	9.9

Screwed

Male - IM

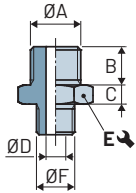

Female - IF

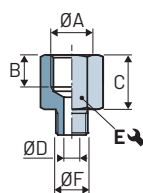

Female - IF 12120

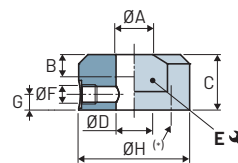

Female - IFS 12120

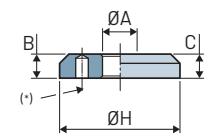

(*) 4 M8 holes at 90° on Ø40 (screws provided)

	Ø A	B	C	Ø D	E ↘	Ø F	G	H	Material	⚖ (g)
IM 14 M10M	G1/4"-M	10	5	5	17	M10x125-M	-	-	Aluminum	7
IF 14 M10M	G1/4"-F	10	17	5	17	M10x125-M	-	-	Aluminum	8.3
IF 12120	G1/2"-F	24	30	19	48	G1/8"-F	8.7	60	Aluminum	224.8
IFS 12120	G1/2"-F	13	13	-	-	-	-	65	Aluminum	143.5

Note: All dimensions are in mm.

VPU

Flat Suction Cups Ø 6 to 50 mm



VPU series suction cups are suitable for gripping flat, smooth and rigid products. They benefit from an excellent hold for vertical gripping.

Materials

NBR Nitrile
SI Translucent Silicone

STN SITON®

Industry-specific applications

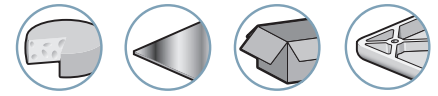

Types of use



2 VPU

Suction Cup Properties

	Ø (mm)	Volume (cm ³)	Force (N) (1)	Force (N) (1)	R _{min} (mm)	NBR	SI	STN
VPU 6	7	0.05	0.9	0.4	5	VPU6NBR	VPU6SI	VPU6STN(*)
VPU 8	9	0.1	1.4	0.7	6	VPU8NBR	VPU8SI	VPU8STN(*)
VPU 10	11	0.018	2.5	1.2	8	VPU10NBR	VPU10SI	VPU10STN(*)
VPU 15	16.5	0.5	4.3	2.2	8	VPU15NBR	VPU15SI	VPU15STN(*)
VPU 20	22	1	6.5	3.3	13	VPU20NBR	VPU20SI	VPU20STN(*)
VPU 30	32	2	13.0	6.5	20	VPU30NBR	VPU30SI	VPU30STN(*)
VPU 40	41	5.5	18.8	9.4	30	VPU40NBR	VPU40SI	VPU40STN(*)
VPU 50	51.4	12	33.2	16.6	35	VPU50NBR	VPU50SI	VPU50STN(*)

(1) Actual force of the suction cup in use with 65% vacuum and including a safety factor of 2 for horizontal handling and a factor of 4 for vertical handling.

(*) On request

Choice of Fittings

(Ø)	M5-M	G1/8"-M	G1/4"-M	G3/8"-M
6...15	■	-	-	-
20...30	-	■	-	-
40...50	-	-	■	■

■ Standard available configurations (suction cup + fitting) Fittings: M = Male
See part n° schedule as below

Type of Assembly



Version C: Barbed fitting



Version E: Pressed fitting

References - "Section Cup + Fitting"

Ø 6 - 15 mm	THREAD	M5-M
	VPU6NBR	VPU6NBRIMM5C
	VPU6SI	VPU6SIIMM5C
	VPU6STN	VPU6STNIMM5C
	VPU8NBR	VPU8NBRIMM5C
	VPU8SI	VPU8SIIMM5C
	VPU8STN	VPU8STNIMM5C
	VPU10NBR	VPU10NBRIMM5C
	VPU10SI	VPU10SIIMM5C
	VPU10STN	VPU10STNIMM5C
	VPU15NBR	VPU15NBRIMM5C
	VPU15SI	VPU15SIIMM5C
VPU15STN	VPU15STNIMM5C	

Ø 20 - 30 mm	THREAD	G1/8"-M	
		Fitting with filter	Fitting without filter
	VPU20NBR	VPU20NBRIM18MPF	VPU20NBRIM18MP
	VPU20SI	VPU20SIIM18MPF	VPU20SIIM18MP
	VPU20STN(*)	VPU20STNIM18MPF	VPU20STNIM18MP
	VPU30NBR	VPU30NBRIM18MPF	VPU30NBRIM18MP
	VPU30SI	VPU30SIIM18MPF	VPU30SIIM18MP
	VPU30STN(*)	VPU30STNIM18MPF	VPU30STNIM18MP

Ø 40 - 50 mm	THREAD	G1/4"-M		G3/8"-M	
		Fitting with filter	Fitting without filter	Fitting with filter	Fitting without filter
	VPU40NBR	VPU40NBRIM14MPF	VPU40NBRIM14MP	VPU40NBRIM38MPF	VPU40NBRIM38MP
	VPU40SI	VPU40SIIM14MPF	VPU40SIIM14MP	VPU40SIIM38MPF	VPU40SIIM38MP
	VPU40STN(*)	VPU40STNIM14MPF	VPU40STNIM14MP	VPU40STNIM38MPF	VPU40STNIM38MP
	VPU50NBR	VPU50NBRIM14MPF	VPU50NBRIM14MP	VPU50NBRIM38MPF	VPU50NBRIM38MP
	VPU50SI	VPU50SIIM14MPF	VPU50SIIM14MP	VPU50SIIM38MPF	VPU50SIIM38MP
	VPU50STN(*)	VPU50STNIM14MPF	VPU50STNIM14MP	VPU50STNIM38MPF	VPU50STNIM38MP

(*) On request

Accessories

To optimize use of your suction cups, Coval offers a comprehensive range of accessories (sensors, spring extensions, and feeder systems, etc.) see chapters 4 and 14.



Please specify the part n°. e.g. VPU20NBRIM18MPF
See part n° table above

VPU

Flat Suction Cups Ø 6 to 50 mm

Assembly Diagrams



Suction Cups + Fittings

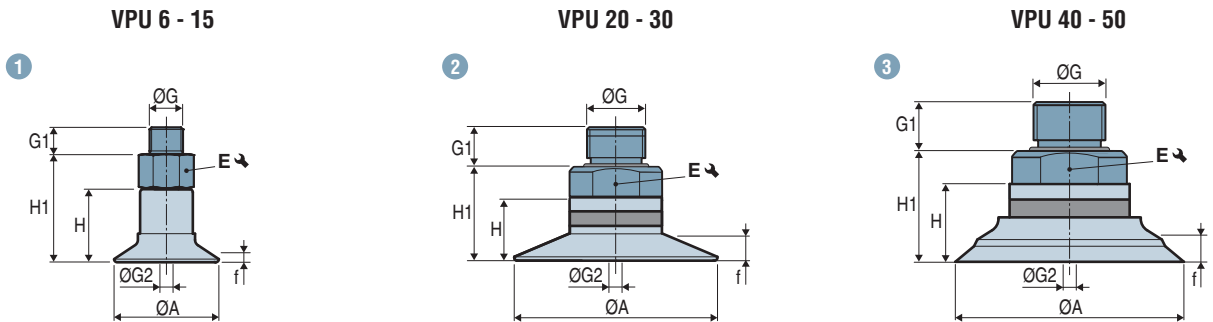
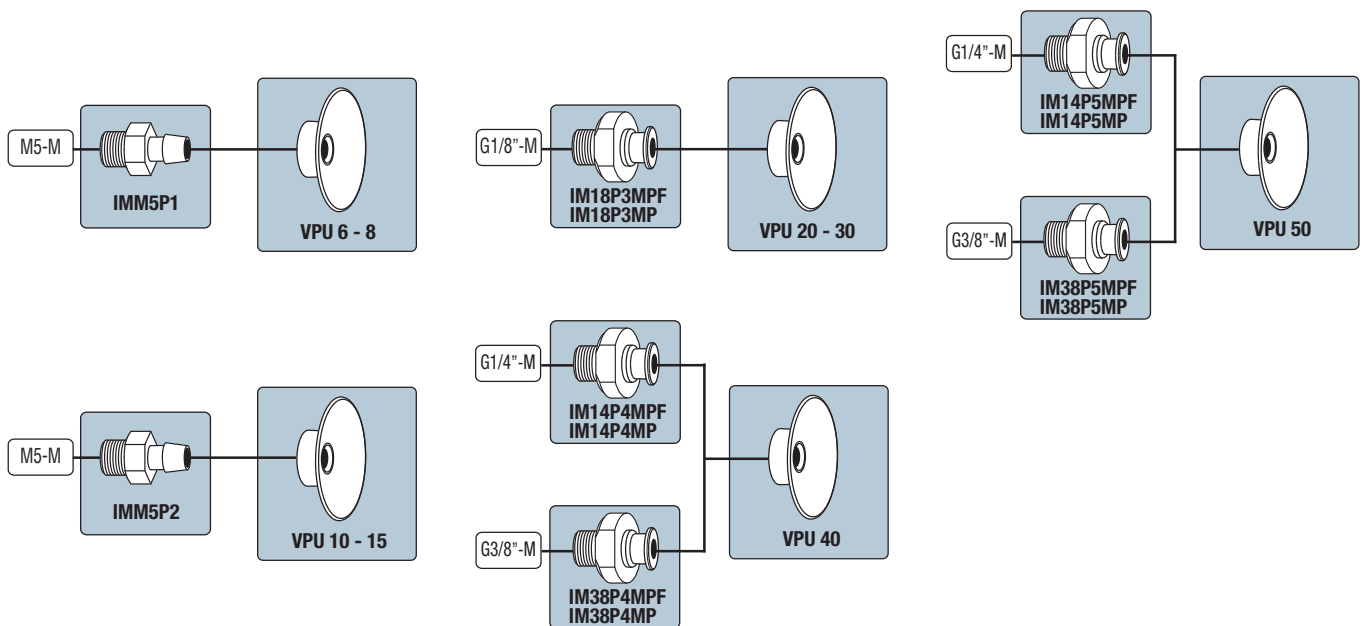

	Diagram	ØA	f ⁽¹⁾	H	H1	ØG	G1	ØG2 ⁽²⁾	E ↘	⊞ (g)
VPU6---IMM5C	1	7	0.3	6.5	10	M5-M	4	1.5	7	1.8
VPU8---IMM5C	1	9	0.5	7	10.5	M5-M	4	1.5	7	1.9
VPU10---IMM5C	1	11	0.5	10.5	15	M5-M	4	2.7	7	1.3
VPU15---IMM5C	1	16.5	1.5	11.5	16	M5-M	4	2.7	7	1.6
VPU20---IM18MP-	2	22	2.5	8	13	G1/8"-M	7	4	13	4.4
VPU30---IM18MP-	2	32	3.5	9.5	14.5	G1/8"-M	7	4	13	5.1
VPU40---IM14MP-	3	41	4.5	13	19	G1/4"-M	9	5	19	12
VPU40---IM38MP-	3	41	4.5	13	19	G3/8"-M	10	5	22	16.6
VPU50---IM14MP-	3	51.4	6	17.5	23.5	G1/4"-M	9	5	22	24.1
VPU50---IM38MP-	3	51.4	6	17.5	23.5	G3/8"-M	10	6	23.9	27.1

(1) f = Deflection of the suction cup.

(2) Ø G2 = Ø internal orifice of the fitting.

Assembly Diagrams



Note: All dimensions are in mm.

VPU

Flat Suction Cups Ø 6 to 50 mm

Dimensions



2
VPU

Suction Cups

VPU 6 - 15

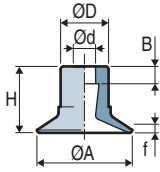

VPU 20 - 30

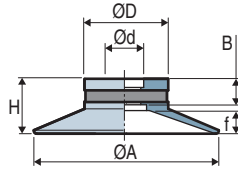

VPU 40 - 50

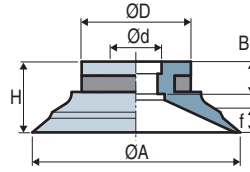

	ØA	H	Ød	ØD	f (1)	B	⚖️ (g)
VPU 6	7	6.5	2	5	0.3	3.5	0.12
VPU 8	9	7	2	5	0.5	3.5	0.15
VPU 10	11	10.5	3.8	9	0.5	3	0.51
VPU 15	16.5	11.5	3.8	8.3	1.5	3	0.75
VPU 20	22	8	5	14.5	2.5	4.5	1.2
VPU 30	32	9.5	5	14.5	3.5	4.5	1.9
VPU 40	41	13	6.5	20	4.5	6	5
VPU 50	51.4	17.5	10.5	27	6	8	12

(1) f = Deflection of the suction cup.

Barbed Fittings

IMM5P1 - IMM5P2

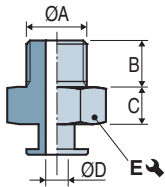

	ØA	B	C	ØD	E	Material	⚖️ (g)
IMM5P1	M5-M	4	3.5	1.5	7	Brass	1.7
IMM5P2	M5-M	4	4.5	2.7	7	Aluminum	0.8

Pressed fittings

Male fittings

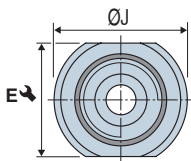
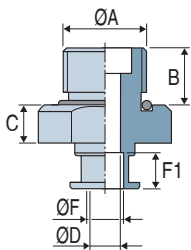

Fitting with stainless steel filter 200 µm	Fitting without filter	ØA	B	C	ØD	E	ØJ	ØF	F1	Materials Fitting*	⚖️ (g)
IM18P3MPF	IM18P3MP	G1/8"-M	7	5	4	13	15	5	4.7	Aluminum	3.2
IM14P4MPF	IM14P4MP	G1/4"-M	9	6	5	19	21	6	5.7	Aluminum	7
IM14P5MPF	IM14P5MP	G1/4"-M	9	6	6	22	28	10	8.7	Aluminum	12.1
IM38P4MPF	IM38P4MP	G3/8"-M	10	6	5	22	24	6	5.7	Aluminum	11.6
IM38P5MPF	IM38P5MP	G3/8"-M	10	6	6	23.9	28	10	8.7	Aluminum	15.1

*Male fittings (IM) equipped with O-ring sealing

Note: All dimensions are in mm.
The values represent the average characteristics of our products.

VPF

Flat Suction Cups with Cleats Ø 15 to 50 mm



VPF series suction cups are suitable for gripping flat, smooth and rigid products. Cleats prevent the deformation of the product and provide excellent non-slip properties.

Industry-specific applications

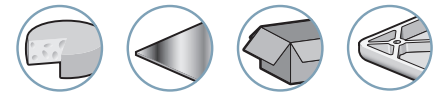

Types of use



Materials

NBR	Nitrile	STN	SITON®
SI	Translucent Silicone		

2
VPF

Suction Cup Properties

	Ø (mm)	(cm³)	(N) (1)	(N) (1)	(mm)	NBR	SI	STN
VPF 15	15.7	0.37	3.6	1.8	13	VPF15NBR	VPF15SI	VPF15STN(*)
VPF 20	22	1.00	7.2	3.6	18	VPF20NBR	VPF20SI	VPF20STN(*)
VPF 25	26.8	1.10	9.4	4.7	22	VPF25NBR	VPF25SI	VPF25STN(*)
VPF 30	32	2.00	11.6	5.8	25	VPF30NBR	VPF30SI	VPF30STN(*)
VPF 40	42.5	1.80	18.1	9.0	52	VPF40NBR	VPF40SI	VPF40STN(*)
VPF 50	53	10.00	34.7	17.3	55	VPF50NBR	VPF50SI	VPF50STN(*)

(1) Actual force of the suction cup in use with 65% vacuum and including a safety factor of 2 for horizontal handling and a factor of 4 for vertical handling.

(*) On request

Choice of Fittings

(Ø)	M5-M	G1/8"-M	G1/4"-M	G3/8"-M
15	■	-	-	-
20 - 30	-	■	-	-
40 - 50	-	-	■	■

■ Standard available configurations (suction cup + fitting) Fittings: M = Male
Refer to n° table above

Type of Assembly

C **Version C: Barbed fitting**

E **Version E: Pressed fitting**

References "Suction Cup + Fitting"

Ø	THREAD	C		E						
		M5-M		G1/8"-M		G1/4"-M		G3/8"-M		
Ø 15 mm	VPF15NBR	VPF15NBRIMM5C		Fitting with filter		Fitting without filter				
	VPF15SI	VPF15SIIMM5C		VPF20NBR	VPF20NBRIM18MPF	VPF20NBRIM18MP	VPF20SI	VPF20SIIM18MPF	VPF20SIIM18MP	
	VPF15STN	VPF15STNIMM5C		VPF20SI	VPF20STNIM18MPF	VPF20STNIM18MP	VPF25NBR	VPF25NBRIM18MPF	VPF25NBRIM18MP	
				VPF25SI	VPF25SIIM18MPF	VPF25SIIM18MP	VPF25STN(*)	VPF25STNIM18MPF	VPF25STNIM18MP	
				VPF30NBR	VPF30NBRIM18MPF	VPF30NBRIM18MP	VPF30SI	VPF30SIIM18MPF	VPF30SIIM18MP	
				VPF30STN(*)	VPF30STNIM18MPF	VPF30STNIM18MP				
Ø 20 - 30 mm				Fitting with filter		Fitting without filter				
	VPF40NBR	VPF40NBRIM14MPF	VPF40NBRIM14MP	VPF40NBRIM38MPF	VPF40NBRIM38MP	VPF40SI	VPF40SIIM14MPF	VPF40SIIM14MP	VPF40SIIM38MPF	VPF40SIIM38MP
	VPF40SI	VPF40SIIM14MPF	VPF40SIIM14MP	VPF40SIIM38MPF	VPF40SIIM38MP	VPF40STN(*)	VPF40STNIM14MPF	VPF40STNIM14MP	VPF40STNIM38MPF	VPF40STNIM38MP
	VPF40STN(*)	VPF40STNIM14MPF	VPF40STNIM14MP	VPF40STNIM38MPF	VPF40STNIM38MP	VPF50NBR	VPF50NBRIM14MPF	VPF50NBRIM14MP	VPF50NBRIM38MPF	VPF50NBRIM38MP
	VPF50NBR	VPF50NBRIM14MPF	VPF50NBRIM14MP	VPF50NBRIM38MPF	VPF50NBRIM38MP	VPF50SI	VPF50SIIM14MPF	VPF50SIIM14MP	VPF50SIIM38MPF	VPF50SIIM38MP
	VPF50SI	VPF50SIIM14MPF	VPF50SIIM14MP	VPF50SIIM38MPF	VPF50SIIM38MP	VPF50STN(*)	VPF50STNIM14MPF	VPF50STNIM14MP	VPF50STNIM38MPF	VPF50STNIM38MP
	VPF50STN(*)	VPF50STNIM14MPF	VPF50STNIM14MP	VPF50STNIM38MPF	VPF50STNIM38MP					

(*) On request

Accessories

To optimize use of your suction cups, Coval offers a comprehensive range of accessories (sensors, spring extensions, and feeder systems, etc.) see chapters 4 and 14.

Please specify the part n°. e.g. VPF20NBRIM18MPF
See part n° table above

VPF

Flat Suction Cups with Cleats Ø 15 to 50 mm

Assembly Diagrams



Suction Cup + Fitting

VPF 15

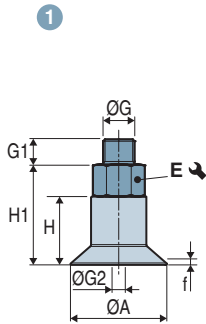

VPF 20...30

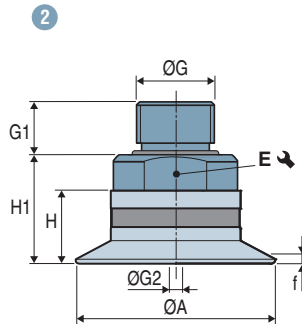

VPF 40...50

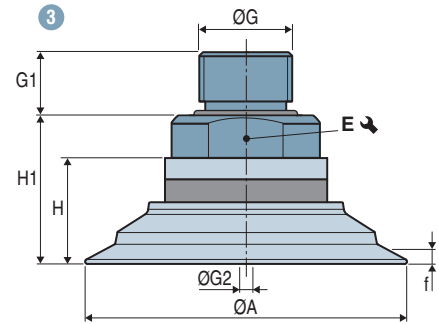

2
VPF

	Diagram	ØA	f ⁽¹⁾	H	H1	ØG	G1	ØG2 ⁽²⁾	E ↘	g (g)
VPF15---IMM5C	1	15.7	1	11	15.5	M5-M	4	2.7	7	1.5
VPF20---IM18MP-	2	22	1	8	13	G1/8"-M	7	4	13	4.4
VPF25---IM18MP-	2	26.8	1.3	9	14	G1/8"-M	7	4	13	4.9
VPF30---IM18MP-	2	32	1.8	10	15	G1/8"-M	7	4	13	5.4
VPF40---IM14MP-	3	42.5	1.9	13	19	G1/4"-M	9	5	19	12.6
VPF40---IM38MP-	3	42.5	1.9	13	19	G3/8"-M	10	5	22	17.2
VPF50---IM14MP-	3	53	2.4	17.5	23.5	G1/4"-M	9	6	22	24.8
VPF50---IM38MP-	3	53	2.4	17.5	23.5	G3/8"-M	10	6	23.9	27.8

(1) f = Deflection of the suction cup. (2) Ø G2 = Ø internal orifice of the fitting.

Assembly Diagrams

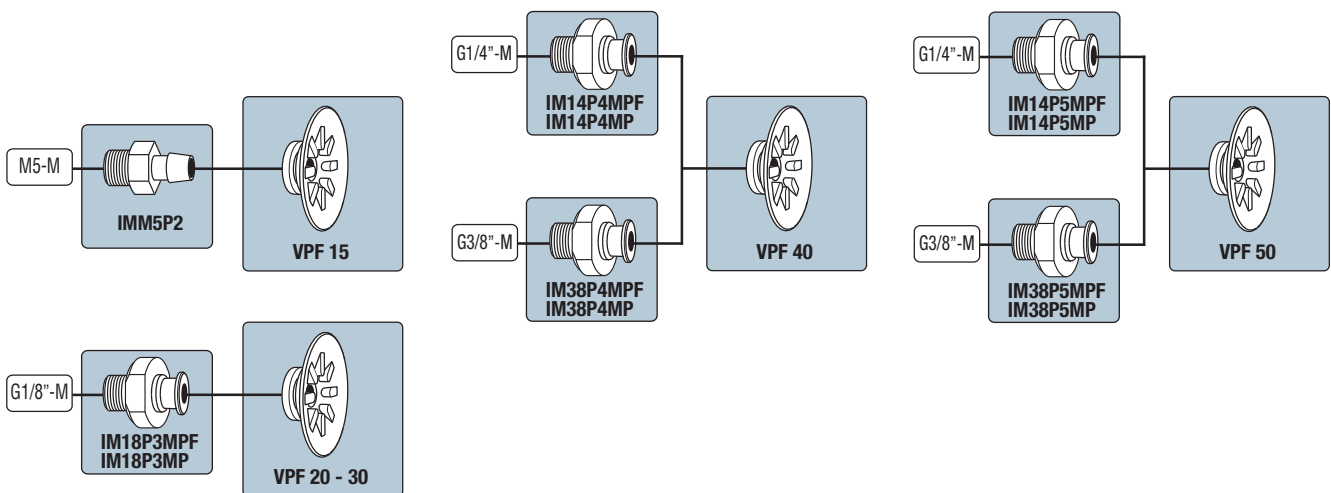

Note: All dimensions are in mm.

VPF

Flat Suction Cups with Cleats Ø 15 to 50 mm Assembly Diagrams



Suction Cups

VPF 15

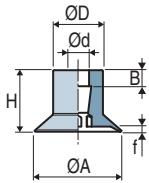

VPF 20...30

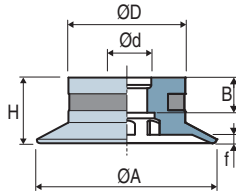

VPF 40...50

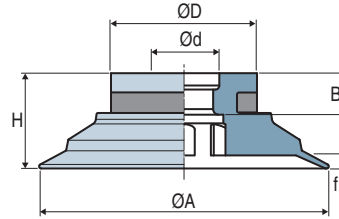

	Ø A	H	Ø d	Ø D	f ⁽¹⁾	B	(g)
 VPF 15	15.7	11	4	9	1	3	0.7
VPF 20	22	8	5	14.3	1	4.5	1.2
VPF 25	26.8	9	5	14.3	1.3	4.5	1.7
VPF 30	32	10	5	14.3	1.8	4.5	2.2
VPF 40	42.5	13	7	20	1.9	6	5.6
VPF 50	53	17.5	10.5	27	2.4	7.5	12.7

(1) f = Deflection of the suction cup.

Barbed Fittings

IMM5P2

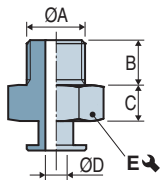

	ØA	B	C	ØD	E	Material	(g)
IMM5P2	M5-M	4	4.5	2.7	7	Aluminum	0.8

Pressed fittings

Male fittings

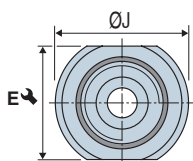
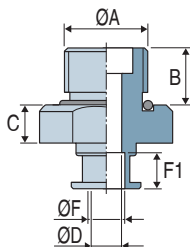

Fitting with stainless steel filter 200 µm	Fitting without filter	ØA	B	C	ØD	E	ØJ	ØF	F1	Materials Fitting*	(g)
IM18P3MPF	IM18P3MP	G1/8"-M	7	5	4	13	15	5	4.7	Aluminum	3.2
IM14P4MPF	IM14P4MP	G1/4"-M	9	6	5	19	21	6	5.7	Aluminum	7
IM14P5MPF	IM14P5MP	G1/4"-M	9	6	6	22	28	10	8.7	Aluminum	12.1
IM38P4MPF	IM38P4MP	G3/8"-M	10	6	5	22	24	6	5.7	Aluminum	11.6
IM38P5MPF	IM38P5MP	G3/8"-M	10	6	6	23.9	28	10	8.7	Aluminum	15.1

*Male fittings (IM) equipped with O-ring sealing

Note: All dimensions are in mm.
The values represent the average characteristics of our products.

VPO

Oblong Flat Suction Cups

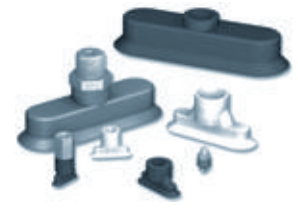

The VPO series of flat suction cups is used for handling oblong products, such as pens, tubes and bottles, and flat or cylindrical objects.

Materials

NBR Nitrile **STN** SITON® **SI** Silicone

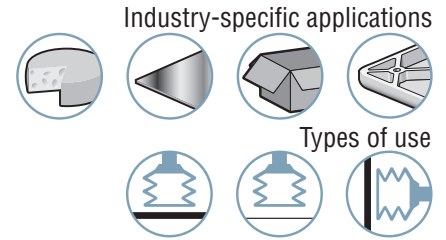

Industry-specific applications

Types of use

VPO 2

Suction Cup Properties

	I x L (mm)	Volume (cm ³)	Force (N) ⁽¹⁾	R _{min} (mm)	NBR	SI	STN
VPO 24	2x4	0.004	0.2	1	VPO24NBR	VPO24SI	VPO24STN
VPO 357	3.5x7	0.019	0.5	3	VPO357NBR	VPO357SI	VPO357STN
VPO 515	5x15	0.036	1.7	4	VPO515NBR	VPO515SI	VPO515STN
VPO 618	6x18	0.058	2.4	4	VPO618NBR	VPO618SI	VPO618STN
VPO 824	8x24	0.138	4.3	8	VPO824NBR	VPO824SI	VPO824STN
VPO 1030	10x30	0.28	6.6	8	VPO1030NBR	VPO1030SI	VPO1030STN
VPO 1545	15x45	0.98	15.3	10	VPO1545NBR	VPO1545SI	VPO1545STN
VPO 2060	20x60	2.3	27.1	20	VPO2060NBR	VPO2060SI	VPO2060STN
VPO 2575	25x75	4.7	42.4	30	VPO2575NBR	VPO2575SI	VPO2575STN
VPO 3090	30x90	8.5	61	35	VPO3090NBR	VPO3090SI	VPO3090STN

(1) Actual force of the suction cup with 65% vacuum and a safety factor of 2 included.

Choice of Fittings

	M3-M	M5-M	M5-F	G1/8"-M	G1/8"-F	G1/4"-M	G1/4"-F
24, 357	■	-	-	-	-	-	-
515, 618	-	■	■	-	-	-	-
824, 1030	-	-	-	■	■	-	-
1545... 3090	-	-	-	-	-	■	■

Collar must be used from 8 x 24 upwards to prevent unintentional rotation when in use.

■ Standard available configurations (suction cup + fitting): refer to n° table above

Fitting: M = male

F = female

Type of Assembly



Version C: Barbed fitting

References - "Suction Cup + Fitting"

Suction Cup	C	
	THREAD	M3-M
2x4, 3.5x7	VPO24NBR	VPO24NBRIMM3C
	VPO24SI	VPO24SIIMM3C
	VPO24STN	VPO24STNIMM3C
	VPO357NBR	VPO357NBRIMM3C
	VPO357SI	VPO357SIIMM3C
	VPO357STN	VPO357STNIMM3C

Suction Cup	C		
	THREAD	M5-M	M5-F
5x15 - 6x18	VPO515NBR	VPO515NBRIMM5C	VPO515NBRIFM5C
	VPO515SI	VPO515SIIMM5C	VPO515SIIFM5C
	VPO515STN	VPO515STNIMM5C	VPO515STNIFM5C
	VPO618NBR	VPO618NBRIMM5C	VPO618NBRIFM5C
	VPO618SI	VPO618SIIMM5C	VPO618SIIFM5C
	VPO618STN	VPO618STNIMM5C	VPO618STNIFM5C

Suction Cup	C		
	THREAD	G1/8"-M	G1/8"-F
8x24 - 10x30	VPO824NBR	VPO824NBRIM18C	VPO824NBRIF18C
	VPO824SI	VPO824SIIM18C	VPO824SIIF18C
	VPO824STN	VPO824STNIM18C	VPO824STNIF18C
	VPO1030NBR	VPO1030NBRIM18C	VPO1030NBRIF18C
	VPO1030SI	VPO1030SIIM18C	VPO1030SIIF18C
	VPO1030STN	VPO1030STNIM18C	VPO1030STNIF18C

Suction Cup	C		
	THREAD	G1/4"-M	G1/4"-F
15x45 - 30x90	VPO1545NBR	VPO1545NBRIM14C	VPO1545NBRIF14C
	VPO1545SI	VPO1545SIIM14C	VPO1545SIIF14C
	VPO1545STN	VPO1545STNIM14C	VPO1545STNIF14C
	VPO2060NBR	VPO2060NBRIM14C	VPO2060NBRIF14C
	VPO2060SI	VPO2060SIIM14C	VPO2060SIIF14C
	VPO2060STN	VPO2060STNIM14C	VPO2060STNIF14C
	VPO2575NBR	VPO2575NBRIM14C	VPO2575NBRIF14C
	VPO2575SI	VPO2575SIIM14C	VPO2575SIIF14C
	VPO2575STN	VPO2575STNIM14C	VPO2575STNIF14C
	VPO3090NBR	VPO3090NBRIM14C	VPO3090NBRIF14C
	VPO3090SI	VPO3090SIIM14C	VPO3090SIIF14C
	VPO3090STN	VPO3090STNIM14C	VPO3090STNIF14C

Accessories

Anti-rotation spring system, see page 4/6



Please specify the part n°. e.g. VPO618NBRIFM5C
See part n° table above

VPO

Oblong Flat Suction Cups

Dimensions - "Suction Cup + Fitting"

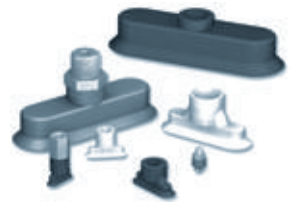

VPO 2x4 - 3.5x7

1

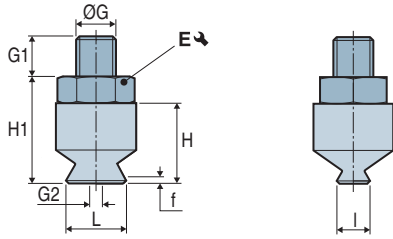

VPO 5x15 - 6x18

2

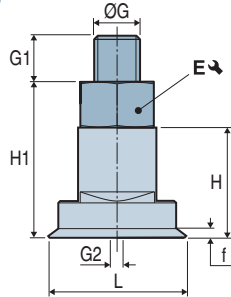

3

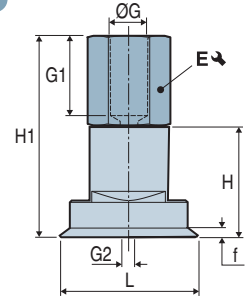

VPO 8x24 - 10x30

4

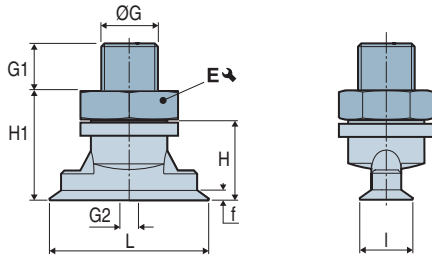

5

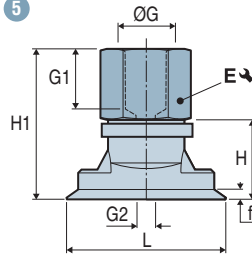

VPO 15x45 - 20x60 - 25x75 - 30x90

6

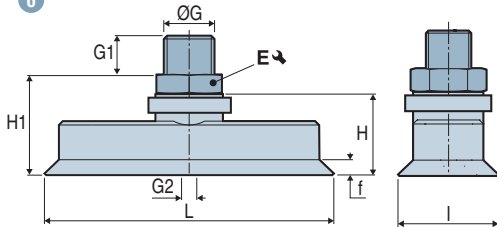

7

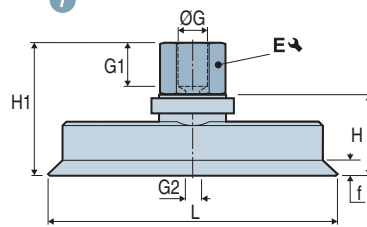

	Diagram	L	I	f ⁽¹⁾	H	H1	ØG	G1	ØG2 ⁽²⁾	E ↘	⊖ (g)
VPO24---IMM3C	1	4	2	0.5	6	8	M3-M	3	1	5	0.4
VPO357---IMM3C	1	7	3.5	0.8	6	8	M3-M	3	1	5	0.3
VPO515---IMM5C	2	15	5	0.7	12	17	M5-M	5	2	8	1.8
VPO515---IFM5C	3	15	5	0.7	12	22	M5-F	8.5	2	8	1.8
VPO618---IMM5C	2	18	6	0.8	12	17	M5-M	5	2	8	1.8
VPO618---IFM5C	3	18	6	0.8	12	22	M5-F	8.5	2	8	1.8
VPO824---IM18C	4	24	8	1	12	17	G1/8"-M	8	3.5	14	6.6
VPO824---IF18C	5	24	8	1	12	25	G1/8"-F	9	3.5	14	7.3
VPO1030---IM18C	4	30	10	1.5	12	17	G1/8"-M	8	3.5	14	6.8
VPO1030---IF18C	5	30	10	1.5	12	25	G1/8"-F	9	3.5	14	7.5
VPO1545---IM14C	6	45	15	2	21	26	G1/4"-M	10	3.5	17	16.5
VPO1545---IF14C	7	45	15	2	21	36	G1/4"-F	12	3.5	17	16.5
VPO2060---IM14C	6	60	20	2.5	21	26	G1/4"-M	10	3.5	17	19.7
VPO2060---IF14C	7	60	20	2.5	21	36	G1/4"-F	12	3.5	17	19.7
VPO2575---IM14C	6	75	25	2.8	21	26	G1/4"-M	10	3.5	17	27.9
VPO2575---IF14C	7	75	25	2.8	21	36	G1/4"-F	12	3.5	17	27.9
VPO3090---IM14C	6	90	30	3.5	21	26	G1/4"-M	10	3.5	17	36.3
VPO3090---IF14C	7	90	30	3.5	21	36	G1/4"-F	12	3.5	17	36.3

Note: All dimensions are in mm.

(1) f = Deflection of the suction cup.

(2) Ø G2 = Ø internal orifice of the fitting.

VPO

Oblong Flat Suction Cups

Assembly Diagrams

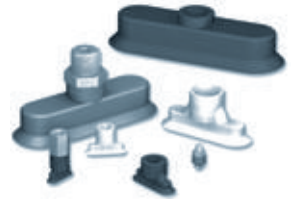

2
VPO

VPO 24 - 357

Barbed fittings   

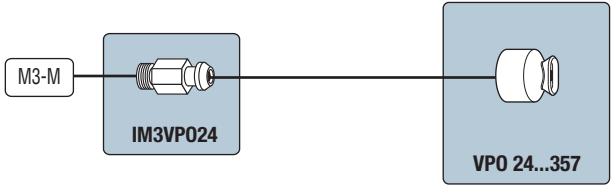

VPO 515 - 618

Barbed fittings   

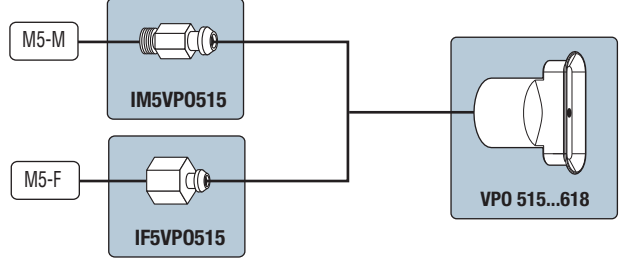

VPO 824 - 1030

Barbed fittings   

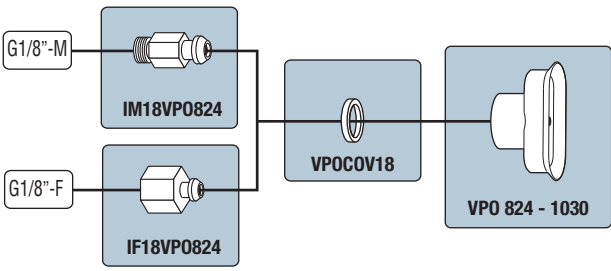

VPO 1545 - 2060 - 2575 - 3090

Barbed fittings   

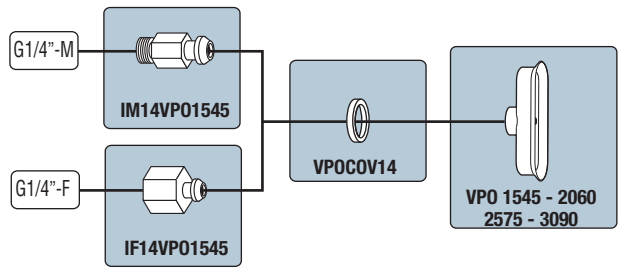

VPO

Oblong Flat Suction Cups

Dimensions

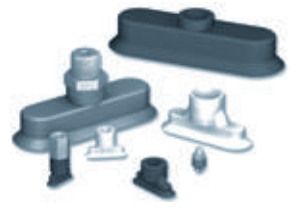

Dimensions Suction Cups

VPO 24 - 357

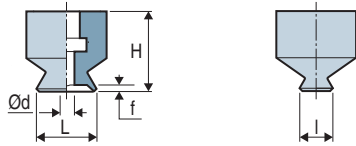

VPO 515 - 618

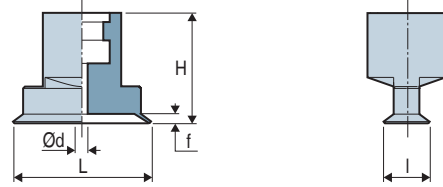

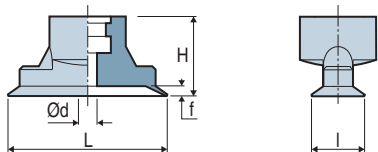

VPO 824 - 1030

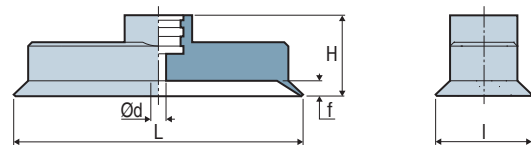

VPO 1545 - 2060 - 2575 - 3090



Suction Cups

	L	l	Ø d	H	f (1)	 (g)
VPO24	4	2	0.7	6	0.5	0.12
VPO357	7	3.5	1	6	0.8	0.15
VPO515	15	5	1.2	12	0.7	0.51
VPO618	18	6	1.5	12	0.8	0.53
VPO824	24	8	1.5	12	1	1.1
VPO1030	30	10	2.5	12	1.5	1.3
VPO1545	45	15	3	21	2	4.1
VPO2060	60	20	4	21	2.5	7.3
VPO2575	75	25	4	21	2.8	15.5
VPO3090	90	30	4	21	3.5	23.9

(1) f = Deflection of the suction cup.

Barbed Fitting

Male - IM

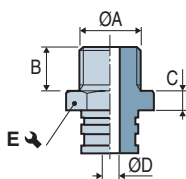

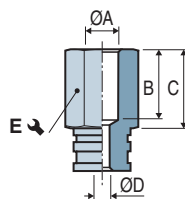

Female - IF

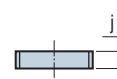

Collar



	ØA	B	C	ØD	E 	j	Material	 (g)
IM3VP024	M3-M	3	2	1	5	-	Aluminum	0.2
IM5VP0515	M5-M	5	5	2	8	-	Aluminum	1.3
IM18VP0824	G1/8"-M	8	5	3.5	14	-	Aluminum	3.9
IM14VP01545	G1/4"-M	10	5	3.5	17	-	Aluminum	9.7
IF5VP0515	M5-F	8.5	10	2	8	-	Aluminum	1.3
IF18VP0824	G1/8"-F	9	13	3.5	14	-	Aluminum	4.6
IF14VP01545	G1/4"-F	12	15	3.5	17	-	Aluminum	9.7
VPO COV18	-	-	-	-	-	4	Aluminum	1.6
VPO COV14	-	-	-	-	-	4	Aluminum	2.7

The values represent the average characteristics of our products.
Note: All dimensions are in mm.

(1) f = Deflection of the suction cup.



VSA series suction cups with bellows combine the advantages of flat suction cups with increased deflection, flexibility and precision. Used for gripping slightly concave or convex objects.

- Flexibility
- Precision
- Deflection

For delicate gripping requiring a very flexible lip (opening bags, gripping tins and flexible aluminum or plastic bottles, etc.), we recommend using 35 Shore A white silicone, SIB. For larger diameters, see page 3/7, MVS series.

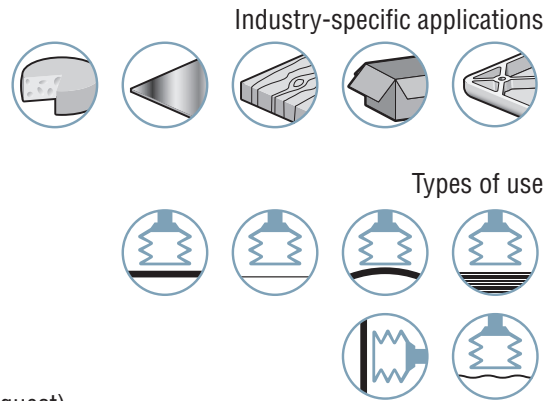

VSA 2

Materials

NBR	Nitrile	SIT5	Translucent silicone
NR	Natural rubber	SIB	35 shore A white silicone
STN	SITON® 60 ShoreA	STN5	SITON® 50 ShoreA (on request)

Suction Cup Properties

	Ø (mm)	Volume (cm³)	Force (N) (1)	Force (N) (1)	R _{min} (mm)	NBR	SIT5	SIB	NR	STN (2)
VSA 5	5.5	0.04	0.5	0.2	10	VSA5NBR	VSA5SIT5	-	-	VSA5STN
VSA 11	11	0.225	1.7	0.9	10	VSA11NBR	VSA11SIT5	-	VSA11NR	VSA11STN
VSA 14	13	0.42	2.5	1.3	13	VSA14NBR	VSA14SIT5	-	VSA14NR	VSA14STN
VSA 16	16	0.75	2.7	1.3	20	VSA16NBR	VSA16SIT5	VSA16SIB	VSA16NR	VSA16STN
VSA 18	18	0.76	4.4	2.2	25	VSA18NBR	VSA18SIT5	VSA18SIB	VSA18NR	VSA18STN
VSA 20	19	1.15	5.6	2.8	30	VSA20NBR	VSA20SIT5	VSA20SIB	VSA20NR	VSA20STN
VSA 22	22	1.4	6.1	3.1	25	VSA22NBR	VSA22SIT5	VSA22SIB	VSA22NR	VSA22STN
VSA 25	24	3.15	7.9	4.0	20	VSA25NBR	VSA25SIT5	VSA25SIB	VSA25NR	VSA25STN
VSA 26	25	3.9	10.8	5.4	30	VSA26NBR	VSA26SIT5	-	VSA26NR	VSA26STN
VSA 33	33	4.75	13.9	6.9	40	VSA33NBR	VSA33SIT5	-	VSA33NR	VSA33STN
VSA 43	43	9.25	20.2	10.1	60	VSA43NBR	VSA43SIT5	-	VSA43NR	VSA43STN
VSA 53	53	26.25	42.6	21.3	75	VSA53NBR	VSA53SIT5	-	VSA53NR	VSA53STN
VSA 63	63	39.0	59.2	29.6	75	VSA63NBR	VSA63SIT5	-	VSA63NR	VSA63STN
VSA 78	78	76.0	109.8	54.9	70	VSA78NBR	VSA78SIT5	-	VSA78NR	VSA78STN

(1) Actual force of the suction cup in use with 65% vacuum and including a safety factor of 2 for horizontal handling and a factor of 4 for vertical handling.

(2) On request, some models are available in STN5 (SITON® 50 shore A)

Choice of Fittings

	Group	M3-M	M5-M	M6-M	M8-M	M10-M	G1/8"-F	G1/8"-M	10/32-M	G1/4"-F	G1/4"-M	G3/8"-M	G1/2"-M
5	1	■	-	-	-	-	-	-	-	-	-	-	-
11...25	1	-	■	■	-	-	■	■	□	-	-	-	-
26...63	2	-	□	□	□	□	■	■	-	■	■	-	-
78	3	-	-	-	-	□	-	■	-	■	■	■	□

■ Standard available configurations (suction cup + fitting): see page 2/28

□ Additional mounting configurations: see page 2/31 Fitting: M = male F = female

Types of Assembly

COVAL suction cups can be assembled in a wide variety of configurations.

C **Version C**
Barbed fitting

S **Version S**
Factory-crimped fitting

V **Version V**
Removable fitting:
(adapter and hollow screw)

E **Version E**
Pressed fitting

Textured Surfaces

For handling objects with a granular or textured gripping surface, use VSA suction cups with the VSBM foam strip option (see page 2/65).

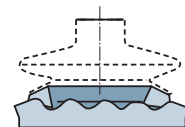

Please specify the part n°. e.g. VSA78NBRIM14C
Refer to page 2/28

Accessories

To optimize the use of your suction cups, Coval offers a comprehensive range of accessories (nozzle fittings, spring extensions, and feeder systems, etc.), see chapters 4 and 14.



Group 1		C				
THREAD	M3-M	M5-M	M6-M	G1/8"-M	G1/8"-F	
VSA5NBR	VSA5NBRIMM3C	-	-	-	-	
VSA5SIT5	VSA5SIT5IMM3C	-	-	-	-	
VSA5STN	VSA5STNIMM3C	-	-	-	-	
VSA11NBR	-	VSA11NBRIMM5C	VSA11NBRIMM6C	VSA11NBRIM18C	VSA11NBRIF18C	
VSA11NR	-	VSA11NRIMM5C	VSA11NRIMM6C	VSA11NRIM18C	VSA11NRIF18C	
VSA11SIT5	-	VSA11SIT5IMM5C	VSA11SIT5IMM6C	VSA11SIT5IM18C	VSA11SIT5IF18C	
VSA11STN	-	VSA11STNIMM5C	VSA11STNIMM6C	VSA11STNIM18C	VSA11STNIF18C	
VSA14NBR	-	VSA14NBRIMM5C	VSA14NBRIMM6C	VSA14NBRIM18C	VSA14NBRIF18C	
VSA14NR	-	VSA14NRIMM5C	VSA14NRIMM6C	VSA14NRIM18C	VSA14NRIF18C	
VSA14SIT5	-	VSA14SIT5IMM5C	VSA14SIT5IMM6C	VSA14SIT5IM18C	VSA14SIT5IF18C	
VSA14STN	-	VSA14STNIMM5C	VSA14STNIMM6C	VSA14STNIM18C	VSA14STNIF18C	
VSA16NBR	-	VSA16NBRIMM5C	VSA16NBRIMM6C	VSA16NBRIM18C	VSA16NBRIF18C	
VSA16NR	-	VSA16NRIMM5C	VSA16NRIMM6C	VSA16NRIM18C	VSA16NRIF18C	
VSA16SIB	-	VSA16SIBIMM5C	VSA16SIBIMM6C	VSA16SIBIM18C	VSA16SIBIF18C	
VSA16SIT5	-	VSA16SIT5IMM5C	VSA16SIT5IMM6C	VSA16SIT5IM18C	VSA16SIT5IF18C	
VSA16STN	-	VSA16STNIMM5C	VSA16STNIMM6C	VSA16STNIM18C	VSA16STNIF18C	
VSA18NBR	-	VSA18NBRIMM5C	VSA18NBRIMM6C	VSA18NBRIM18C	VSA18NBRIF18C	
VSA18NR	-	VSA18NRIMM5C	VSA18NRIMM6C	VSA18NRIM18C	VSA18NRIF18C	
VSA18SIB	-	VSA18SIBIMM5C	VSA18SIBIMM6C	VSA18SIBIM18C	VSA18SIBIF18C	
VSA18SIT5	-	VSA18SIT5IMM5C	VSA18SIT5IMM6C	VSA18SIT5IM18C	VSA18SIT5IF18C	
VSA18STN	-	VSA18STNIMM5C	VSA18STNIMM6C	VSA18STNIM18C	VSA18STNIF18C	
VSA20NBR	-	VSA20NBRIMM5C	VSA20NBRIMM6C	VSA20NBRIM18C	VSA20NBRIF18C	
VSA20NR	-	VSA20NRIMM5C	VSA20NRIMM6C	VSA20NRIM18C	VSA20NRIF18C	
VSA20SIB	-	VSA20SIBIMM5C	VSA20SIBIMM6C	VSA20SIBIM18C	VSA20SIBIF18C	
VSA20SIT5	-	VSA20SIT5IMM5C	VSA20SIT5IMM6C	VSA20SIT5IM18C	VSA20SIT5IF18C	
VSA20STN	-	VSA20STNIMM5C	VSA20STNIMM6C	VSA20STNIM18C	VSA20STNIF18C	
VSA22NBR	-	VSA22NBRIMM5C	VSA22NBRIMM6C	VSA22NBRIM18C	VSA22NBRIF18C	
VSA22NR	-	VSA22NRIMM5C	VSA22NRIMM6C	VSA22NRIM18C	VSA22NRIF18C	
VSA22SIB	-	VSA22SIBIMM5C	VSA22SIBIMM6C	VSA22SIBIM18C	VSA22SIBIF18C	
VSA22SIT5	-	VSA22SIT5IMM5C	VSA22SIT5IMM6C	VSA22SIT5IM18C	VSA22SIT5IF18C	
VSA22STN	-	VSA22STNIMM5C	VSA22STNIMM6C	VSA22STNIM18C	VSA22STNIF18C	
VSA25NBR	-	VSA25NBRIMM5C	VSA25NBRIMM6C	VSA25NBRIM18C	VSA25NBRIF18C	
VSA25NR	-	VSA25NRIMM5C	VSA25NRIMM6C	VSA25NRIM18C	VSA25NRIF18C	
VSA25SIB	-	VSA25SIBIMM5C	VSA25SIBIMM6C	VSA25SIBIM18C	VSA25SIBIF18C	
VSA25SIT5	-	VSA25SIT5IMM5C	VSA25SIT5IMM6C	VSA25SIT5IM18C	VSA25SIT5IF18C	
VSA25STN	-	VSA25STNIMM5C	VSA25STNIMM6C	VSA25STNIM18C	VSA25STNIF18C	

Additional mounting configurations are available (see page 2/31). For standard configurations (suction cup+fitting), the C and V versions are delivered unassembled.

Group 2		C		E		V		
THREAD	G1/4"-M	G1/4"-F	G1/4"-M	G1/4"-F	G1/8"-M	G1/8"-F	G1/4"-M	G1/4"-F
VSA26NBR	VSA26NBRIM14C	VSA26NBRIF14C	VSA26NBRIM14	VSA26NBRIF14	VSA26NBRIM18V	VSA26NBRIF18V	VSA26NBRIM14V	VSA26NBRIF14V
VSA26NR	VSA26NRIM14C	VSA26NRIF14C	VSA26NRIM14	VSA26NRIF14	VSA26NRIM18V	VSA26NRIF18V	VSA26NRIM14V	VSA26NRIF14V
VSA26SIT5	VSA26SIT5IM14C	VSA26SIT5IF14C	VSA26SIT5IM14	VSA26SIT5IF14	VSA26SIT5IM18V	VSA26SIT5IF18V	VSA26SIT5IM14V	VSA26SIT5IF14V
VSA26STN	VSA26STNIM14C	VSA26STNIF14C	VSA26STNIM14	VSA26STNIF14	VSA26STNIM18V	VSA26STNIF18V	VSA26STNIM14V	VSA26STNIF14V
VSA33NBR	VSA33NBRIM14C	VSA33NBRIF14C	VSA33NBRIM14	VSA33NBRIF14	VSA33NBRIM18V	VSA33NBRIF18V	VSA33NBRIM14V	VSA33NBRIF14V
VSA33NR	VSA33NRIM14C	VSA33NRIF14C	VSA33NRIM14	VSA33NRIF14	VSA33NRIM18V	VSA33NRIF18V	VSA33NRIM14V	VSA33NRIF14V
VSA33SIT5	VSA33SIT5IM14C	VSA33SIT5IF14C	VSA33SIT5IM14	VSA33SIT5IF14	VSA33SIT5IM18V	VSA33SIT5IF18V	VSA33SIT5IM14V	VSA33SIT5IF14V
VSA33STN	VSA33STNIM14C	VSA33STNIF14C	VSA33STNIM14	VSA33STNIF14	VSA33STNIM18V	VSA33STNIF18V	VSA33STNIM14V	VSA33STNIF14V
VSA43NBR	VSA43NBRIM14C	VSA43NBRIF14C	VSA43NBRIM14	VSA43NBRIF14	VSA43NBRIM18V	VSA43NBRIF18V	VSA43NBRIM14V	VSA43NBRIF14V
VSA43NR	VSA43NRIM14C	VSA43NRIF14C	VSA43NRIM14	VSA43NRIF14	VSA43NRIM18V	VSA43NRIF18V	VSA43NRIM14V	VSA43NRIF14V
VSA43SIT5	VSA43SIT5IM14C	VSA43SIT5IF14C	VSA43SIT5IM14	VSA43SIT5IF14	VSA43SIT5IM18V	VSA43SIT5IF18V	VSA43SIT5IM14V	VSA43SIT5IF14V
VSA43STN	VSA43STNIM14C	VSA43STNIF14C	VSA43STNIM14	VSA43STNIF14	VSA43STNIM18V	VSA43STNIF18V	VSA43STNIM14V	VSA43STNIF14V
VSA53NBR	VSA53NBRIM14C	VSA53NBRIF14C	VSA53NBRIM14	VSA53NBRIF14	VSA53NBRIM18V	VSA53NBRIF18V	VSA53NBRIM14V	VSA53NBRIF14V
VSA53NR	VSA53NRIM14C	VSA53NRIF14C	VSA53NRIM14	VSA53NRIF14	VSA53NRIM18V	VSA53NRIF18V	VSA53NRIM14V	VSA53NRIF14V
VSA53SIT5	VSA53SIT5IM14C	VSA53SIT5IF14C	VSA53SIT5IM14	VSA53SIT5IF14	VSA53SIT5IM18V	VSA53SIT5IF18V	VSA53SIT5IM14V	VSA53SIT5IF14V
VSA53STN	VSA53STNIM14C	VSA53STNIF14C	VSA53STNIM14	VSA53STNIF14	VSA53STNIM18V	VSA53STNIF18V	VSA53STNIM14V	VSA53STNIF14V
VSA63NBR	VSA63NBRIM14C	VSA63NBRIF14C	VSA63NBRIM14	VSA63NBRIF14	VSA63NBRIM18V	VSA63NBRIF18V	VSA63NBRIM14V	VSA63NBRIF14V
VSA63NR	VSA63NRIM14C	VSA63NRIF14C	VSA63NRIM14	VSA63NRIF14	VSA63NRIM18V	VSA63NRIF18V	VSA63NRIM14V	VSA63NRIF14V
VSA63SIT5	VSA63SIT5IM14C	VSA63SIT5IF14C	VSA63SIT5IM14	VSA63SIT5IF14	VSA63SIT5IM18V	VSA63SIT5IF18V	VSA63SIT5IM14V	VSA63SIT5IF14V
VSA63STN	VSA63STNIM14C	VSA63STNIF14C	VSA63STNIM14	VSA63STNIF14	VSA63STNIM18V	VSA63STNIF18V	VSA63STNIM14V	VSA63STNIF14V

Group 3		V			S		
THREAD	G1/8"-M	G1/4"-M	G1/4"-F	G1/4"-M	G1/4"-F	G3/8"-M	
VSA78NBR	VSA78NBRIM18V	VSA78NBRIM14V	VSA78NBRIF14V	VSA78NBRIM14	VSA78NBRIF14	VSA78NBRIM38	
VSA78NR	VSA78NRIM18V	VSA78NRIM14V	VSA78NRIF14V	VSA78NRIM14	VSA78NRIF14	VSA78NRIM38	
VSA78SIT5	VSA78SIT5IM18V	VSA78SIT5IM14V	VSA78SIT5IF14V	VSA78SIT5IM14	VSA78SIT5IF14	VSA78SIT5IM38	
VSA78STN	VSA78STNIM18V	VSA78STNIM14V	VSA78STNIF14V	VSA78STNIM14	VSA78STNIF14	VSA78STNIM38	



VSA 5 Group 1 **VSA 11 - 25 Group 1**

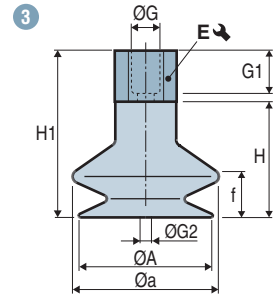
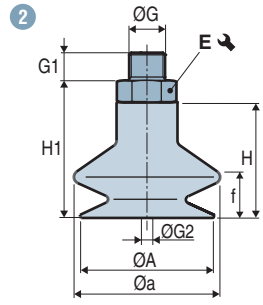
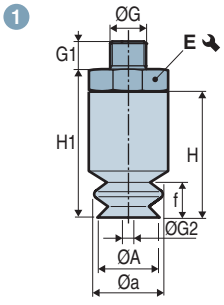

VSA 26 - 43 Group 2 **VSA 53 - 63 Group 2 / VSA 78 Group 3**

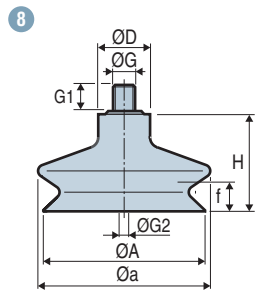
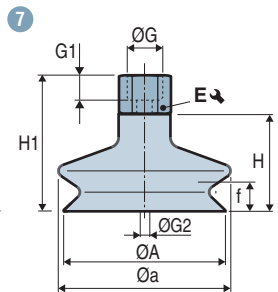
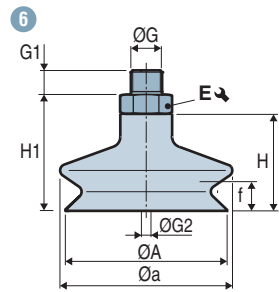
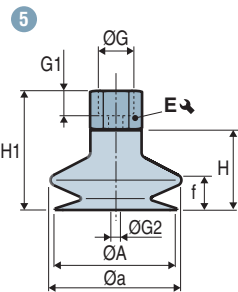
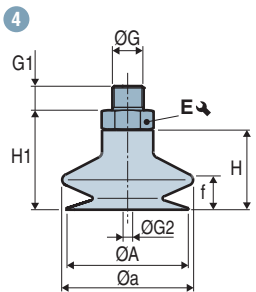

Group 1	Diagram	ØA	Øa	ØD	f ⁽¹⁾	H	H1	ØG	G1	ØG2 ⁽²⁾	E ↘	⊕ (g)
VSA5---IMM3C	1	5.5	6	-	2	11	13	M3-M	3	1.4	5	0.7
VSA11---IMM5C	2	11	12.2	-	5.5	16	21	M5-M	4.5	2.5	7	4
VSA11---IMM6C	2	11	12.2	-	5.5	16	21	M6-M	5	3.5	7	3.6
VSA11---IM18C	2	11	12.2	-	5.5	16	22	G1/8"-M	7.5	3.5	14	5
VSA11---IF18C	3	11	12.2	-	5.5	16	28	G1/8"-F	8	3.5	14	4.9
VSA14---IMM5C	2	13	14	-	5	16	21	M5-M	4.5	2.5	7	4.2
VSA14---IMM6C	2	13	14	-	5	16	21	M6-M	5	3.5	7	3.8
VSA14---IM18C	2	13	14	-	5	16	22	G1/8"-M	7.5	3.5	14	5.2
VSA14---IF18C	3	13	14	-	5	16	28	G1/8"-F	8	3.5	14	5.1
VSA16---IMM5C	2	16	17.3	-	8.5	19	24	M5-M	4.5	2.5	7	4.4
VSA16---IMM6C	2	16	17.3	-	8.5	19	24	M6-M	5	3.5	7	4
VSA16---IM18C	2	16	17.3	-	8.5	19	25	G1/8"-M	7.5	3.5	14	5.4
VSA16---IF18C	3	16	17.3	-	8.5	19	31	G1/8"-F	8	3.5	14	5.3
VSA18---IMM5C	2	18	18	-	5	16.5	21.5	M5-M	4.5	2.5	7	4.6
VSA18---IMM6C	2	18	18	-	5	16.5	21.5	M6-M	5	3.5	7	4.2
VSA18---IM18C	2	18	18	-	5	16.5	22.5	G1/8"-M	7.5	3.5	14	5.6
VSA18---IF18C	3	18	18	-	5	16.5	28.5	G1/8"-F	8	3.5	14	5.5
VSA20---IMM5C	2	19	20	-	5	16	21	M5-M	4.5	2.5	7	4.8
VSA20---IMM6C	2	19	20	-	5	16	21	M6-M	5	3.5	7	5.8
VSA20---IM18C	2	19	20	-	5	16	22	G1/8"-M	7.5	3.5	14	5.8
VSA20---IF18C	3	19	20	-	5	16	28	G1/8"-F	8	3.5	14	5.7
VSA22---IMM5C	2	22	24	-	8	19	24	M5-M	4.5	2.5	7	5.2
VSA22---IMM6C	2	22	24	-	8	19	24	M6-M	5	3.5	7	4.8
VSA22---IM18C	2	22	24	-	8	19	25	G1/8"-M	7.5	3.5	14	6.2
VSA22---IF18C	3	22	24	-	8	19	31	G1/8"-F	8	3.5	14	6.1
VSA25---IMM5C	2	24	25	-	10	23	28	M5-M	4.5	2.5	7	6
VSA25---IMM6C	2	24	25	-	10	23	28	M6-M	5	3.5	7	5.8
VSA25---IM18C	2	24	25	-	10	23	29	G1/8"-M	7.5	3.5	14	7
VSA25---IF18C	3	24	25	-	10	23	35	G1/8"-F	8	3.5	14	6.9

Note: All dimensions are in mm. (1) f = Deflection of the suction cup. (2) Ø G2 = Ø internal orifice of the fitting.



Group 2	Diagram	ØA	Øa	ØD	f ⁽¹⁾	H	H1	ØG	G1	ØG2 ⁽²⁾	E ↻	⊖ (g)	
Ø 26 - 63 mm	VSA26---IM18V	4	25	30	-	6	25	29.5	G1/8"-M	6	3.5	13	18.7
	VSA26---IF18V	5	25	30	-	6	25	38	G1/8"-F	7.5	3.5	13	22
	VSA26---IM14	4	25	30	-	6	25	29	G1/4"-M	11	4.4	17	12.4
	VSA26---IM14C	4	25	30	-	6	25	33	G1/4"-M	10	7	17	13.3
	VSA26---IM14V	4	25	30	-	6	25	30	G1/4"-M	8	3.5	17	28
	VSA26---IF14	5	25	30	-	6	25	40	G1/4"-F	10	4.4	17	13
	VSA26---IF14C	5	25	30	-	6	25	40	G1/4"-F	12	6.9	17	12.6
	VSA26---IF14V	5	25	30	-	6	25	41	G1/4"-F	11	3.5	17	32.6
	VSA33---IM18V	4	33	36.2	-	11	27.5	32	G1/8"-M	6	3.5	13	21.1
	VSA33---IF18V	5	33	36.2	-	11	27.5	40.5	G1/8"-F	7.5	3.5	13	24.4
	VSA33---IM14	4	33	36.2	-	11	27.5	31.5	G1/4"-M	11	4.4	17	14.8
	VSA33---IM14C	4	33	36.2	-	11	27.5	35.5	G1/4"-M	10	7	17	15.7
	VSA33---IM14V	4	33	36.2	-	11	27.5	32.5	G1/4"-M	8	3.5	17	30.4
	VSA33---IF14	5	33	36.2	-	11	27.5	42.5	G1/4"-F	10	4.4	17	15.4
	VSA33---IF14C	5	33	36.2	-	11	27.5	42.5	G1/4"-F	12	6.9	17	15
	VSA33---IF14V	5	33	36.2	-	11	27.5	43.5	G1/4"-F	11	3.5	17	35
	VSA43---IM18V	4	43	46	-	12.5	28	32.5	G1/8"-M	6	3.5	13	25.9
	VSA43---IF18V	5	43	46	-	12.5	28	41	G1/8"-F	7.5	3.5	13	29.2
	VSA43---IM14	4	43	46	-	12.5	28	32	G1/4"-M	11	4.4	17	19.6
	VSA43---IM14C	4	43	46	-	12.5	28	36	G1/4"-M	10	7	17	20.5
	VSA43---IM14V	4	43	46	-	12.5	28	33	G1/4"-M	8	3.5	17	35.2
	VSA43---IF14	5	43	46	-	12.5	28	43	G1/4"-F	10	4.4	17	20.2
	VSA43---IF14C	5	43	46	-	12.5	28	43	G1/4"-F	12	6.9	17	19.8
	VSA43---IF14V	5	43	46	-	12.5	28	44	G1/4"-F	11	3.5	17	39.8
	VSA53---IM18V	6	53	59	-	15	34	38.5	G1/8"-M	6	3.5	13	35
	VSA53---IF18V	7	53	59	-	15	34	47	G1/8"-F	7.5	3.5	13	38.3
	VSA53---IM14	6	53	59	-	15	34	38	G1/4"-M	11	4.4	17	28.7
	VSA53---IM14C	6	53	59	-	15	34	42	G1/4"-M	10	7	17	29.6
	VSA53---IM14V	6	53	59	-	15	34	39	G1/4"-M	8	3.5	17	44.3
	VSA53---IF14	7	53	59	-	15	34	49	G1/4"-F	10	4.4	17	29.3
VSA53---IF14C	7	53	59	-	15	34	49	G1/4"-F	12	6.9	17	28.9	
VSA53---IF14V	7	53	59	-	15	34	50	G1/4"-F	11	3.5	17	48.9	
VSA63---IM18V	6	63	67	-	15	34	38.5	G1/8"-M	6	3.5	13	39.1	
VSA63---IF18V	7	63	67	-	15	34	47	G1/8"-F	7.5	3.5	13	42.4	
VSA63---IM14	6	63	67	-	15	34	38	G1/4"-M	11	4.4	17	32.8	
VSA63---IM14C	6	63	67	-	15	34	42	G1/4"-M	10	7	17	33.7	
VSA63---IM14V	6	63	67	-	15	34	39	G1/4"-M	8	3.5	17	48.4	
VSA63---IF14	7	63	67	-	15	34	49	G1/4"-F	10	4.4	17	33.4	
VSA63---IF14C	7	63	67	-	15	34	49	G1/4"-F	12	6.9	17	33	
VSA63---IF14V	7	63	67	-	15	34	50	G1/4"-F	11	3.5	17	53	

Group 3

Ø 78 mm	VSA78---IM18V	8	78	83	25	14	46.8	-	G1/8"-M	8	6	-	85.4
	VSA78---IM14	6	78	83	-	14	46.8	52.8	G1/4"-M	11	8	21	70.2
	VSA78---IM14V	6	78	83	-	14	46.8	51.8	G1/4"-M	8	6	17	92.7
	VSA78---IF14	7	78	83	-	14	46.8	61.8	G1/4"-F	10	8	21	74.1
	VSA78---IF14V	7	78	83	-	14	46.8	65.8	G1/4"-F	9	6	17	102.3
	VSA78---IM38	6	78	83	-	14	46.8	52.8	G3/8"-M	11	8	21	72.4

Note: All dimensions are in mm.

(1) f = Deflection of the suction cup. (2) Ø G2 = Ø internal orifice of the fitting.

VSA

Suction Cups with 1.5 Bellows Ø 5 to 78 mm

Assembly Diagrams



2
VSA

VSA 5 - 25 Group 1

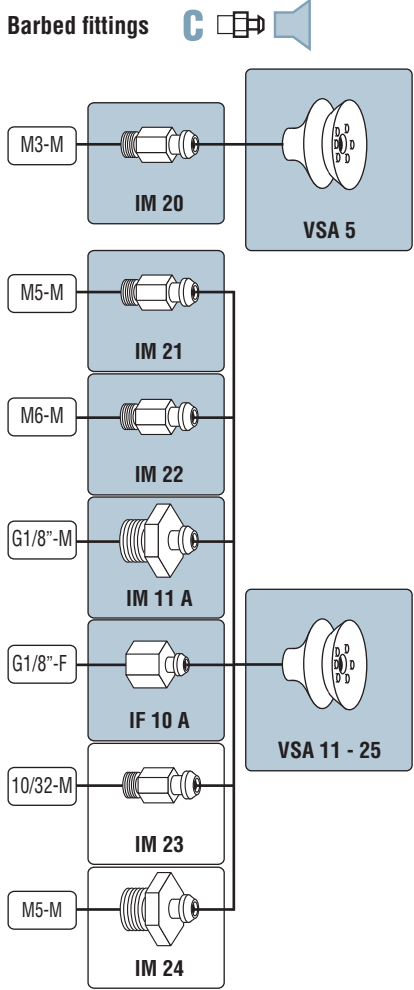

VSA 26 - 63 Group 2

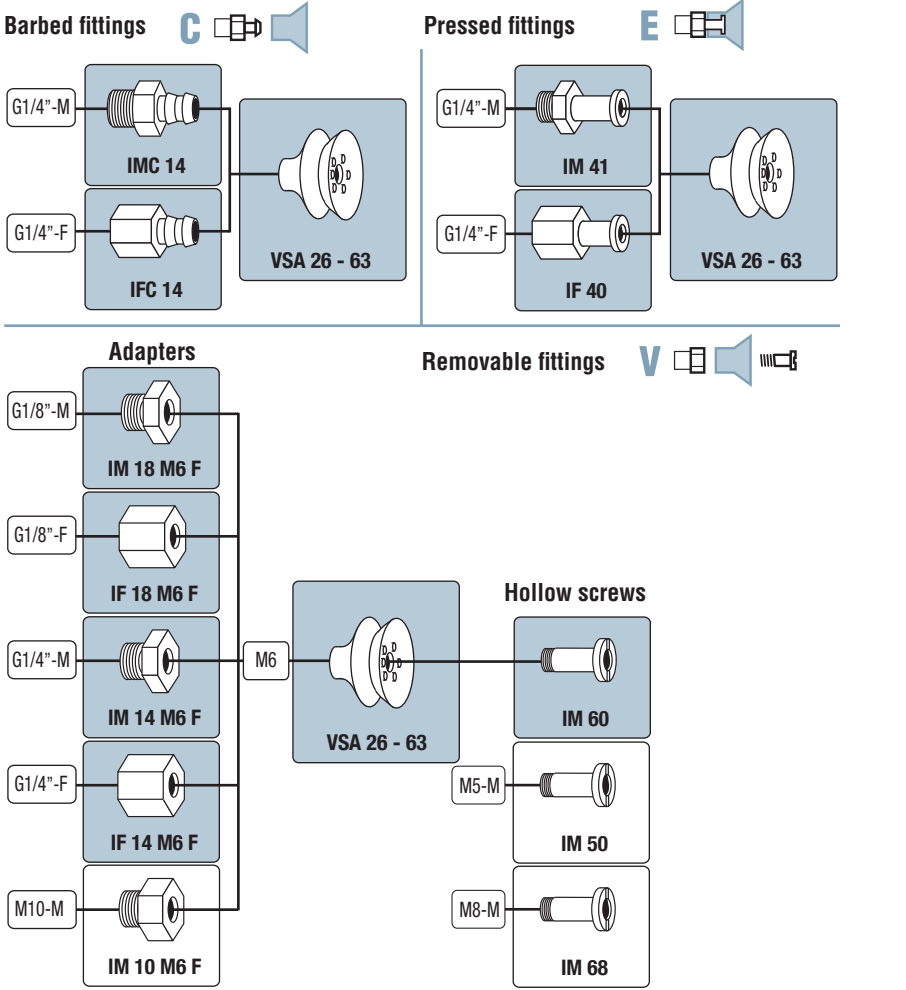

VSA 78 Group 3

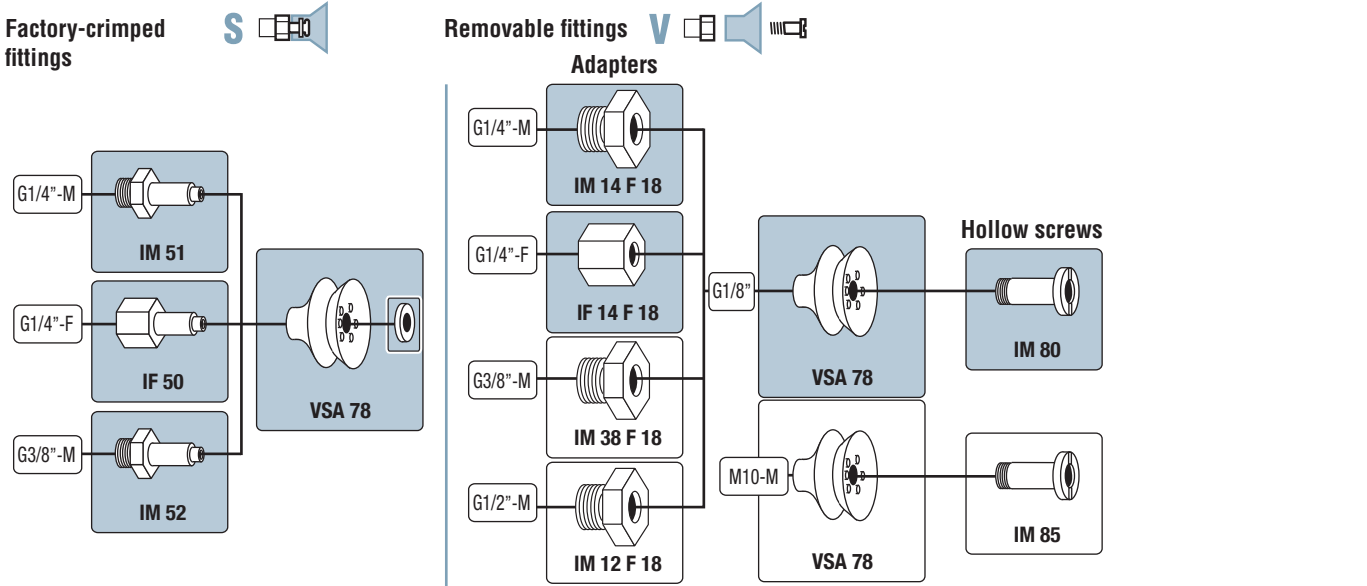

Configurations (suction cup + fitting) refer to pages 2/28

Non-standard configurations must be ordered in separate part numbers.

Fittings and suction cups dimensions: see page 2/32.



Suction Cups

VSA 5

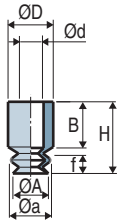

VSA 11 - 25

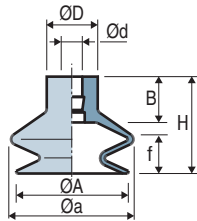

VSA 26 - 78

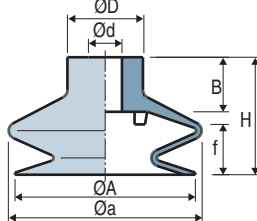

	Ø A	H	Ø a	Ø d	Ø D	f ⁽¹⁾	B	
VSA 5	5.5	11	6	4	7	2	7	0.3
VSA 11	11	16	12.2	4	10	5.5	9	0.9
VSA 14	13	16	14	4	10	5	9	1.1
VSA 16	16	19	17.3	4	10	8.5	9	1.3
VSA 18	18	16.5	18	4	10	5	9	1.5
VSA 20	19	16	20	4	10	5	9	1.7
VSA 22	22	19	24	4	10	8	9	2.1
VSA 25	24	23	25	4	10	10	9	2.9
VSA 26	25	25	30	8	16	6	13	4.6
VSA 33	33	27.5	36.2	8	18	11	13	7
VSA 43	43	28	46	8	18	12.5	13	11.8
VSA 53	53	34	59	8	18	15	13	20.9
VSA 63	63	34	67	8	18	15	13	25
VSA 78	78	46.8	83	12	25	14	20	58.4

Pressed Fittings

Male - IM

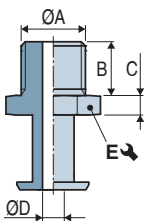

Female - IF

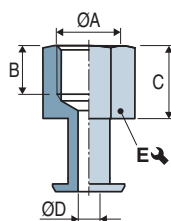

	ØA	B	C	ØD	E	Material	
IM41	G1/4"-M	11	4	4.4	17	Aluminum	7.8
IF40	G1/4"-F	10	15	4.4	17	Aluminum	8.4

Factory-Crimped Fittings

Male - IM

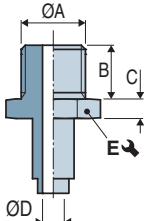

Female - IF

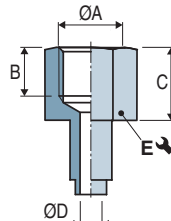

	ØA	B	C	ØD	E	Material	
IM 51	G1/4"-M	11	6	4.4	17	Aluminum	11.8
IF 50	G1/4"-F	10	15	8	21	Aluminum	15.7
IM 52	G3/8"-M	11	6	8	21	Aluminum	14

Hollow Screws

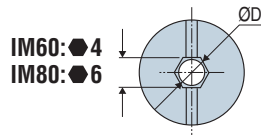
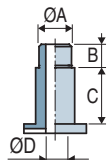

	ØA	B	C	ØD	Material	
IM 50	M5-M	5	11	2.8	Brass	7.4
IM 60 ^{(2) (3)}	M6-M	7	11	3.5	Nickel-plated brass	7.5
IM 68	M8-M	8	11	5.2	Nickel-plated brass	6.4
IM 80	G1/8"-M	8	18	6	Nickel-plated brass	23.7
IM 85	M10x150-M	8	18	6	Nickel-plated brass	23.5

The values represent the average characteristics of our products.

(2) Flow restrictor version available: orifice calibrated to reduce leaks when used with a multi-cup gripper (see page 4/10)

(3) Available in stainless steel

Barbed Fittings

Male - IM

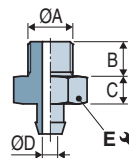

Female - IF

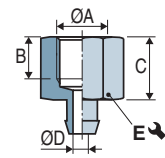

	ØA	B	C	ØD	E	Material	
IM 11 A	G1/8"-M	7.5	6	3.5	14	Aluminum	4.1
IMC 14	G1/4"-M	10	8	7	17	Aluminum	8.7
IM20	M3-M	3	2	1.4	5	Aluminum	0.4
IM 21 ⁽²⁾	M5-M	4.5	5	2.5	7	Nickel-plated brass	3.1
IM 22 ⁽²⁾	M6-M	5	5	3.5	7	Nickel-plated brass	2.7
IM 23	10/32-M	4.5	5	2.5	7	Brass	3
IM 24	M5-M	4.5	2.5	2.5	10	Nickel-plated brass	3.2
IF 10 A	G1/8"-F	8	12	3.5	14	Aluminum	4
IFC 14	G1/4"-F	12	15	6.9	17	Aluminum	8

Adapters for Hollow Screws

Male - IM

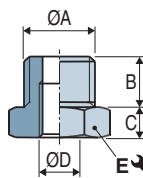

Female - IF

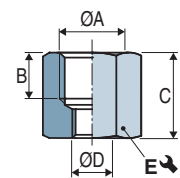

	ØA	B	C	ØD	E	Material	
IM 10 M6F	M10-M	7	3.5	M6-F	13	Brass	5.9
IM 12 F18	G1/2"-M	14	6	M6-F	22	Nickel-plated brass	46.5
IM 14 M6F	G1/4"-M	8	5	M6-F	17	Nickel-plated brass	15.9
IM 14 F18	G1/4"-M	8	5	G1/8"-F	17	Nickel-plated brass	10.6
IM 18 M6F	G1/8"-M	6	4.5	M6-F	13	Nickel-plated brass	6.6
IM 38 F18	G3/8"-M	9	5	G1/8"-F	19	Nickel-plated brass	18.8
IF 14 M6F	G1/4"-F	11	16	M6-F	17	Nickel-plated brass	20.5
IF 18 M6F	G1/8"-F	7.5	13	M6-F	13	Nickel-plated brass	9.9
IF 14 F18	G1/4"-F	9	19	G1/8"-F	17	Nickel-plated brass	20.2

Note: All dimensions are in mm.

VSAB

Suction Cups with 1.5 Bellows Ø 5 to 50 mm



The VSAB series 1.5 bellows suction cups are suitable for gripping slightly concave or convex products. And due to their stroke, VSAB cups are capable of gripping products at varying heights.

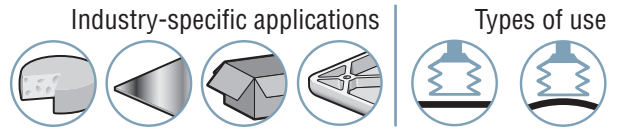

Materials

NBR Nitrile **STN** SITON® **SI** Translucent silicone

2 VSAB

Suction Cup Properties

	Ø (mm)	(cm ³)	(N) ⁽¹⁾	(N) ⁽¹⁾	(mm)	NBR	SI	STN
VSAB 5	5.6	0.05	0.4	0.1	1.5	VSAB5NBR	VSAB5SI	VSAB5STN
VSAB 8	8.8	0.15	0.9	0.4	1.9	VSAB8NBR	VSAB8SI	VSAB8STN
VSAB 10	11	0.48	1.7	0.9	4	VSAB10NBR	VSAB10SI	VSAB10STN
VSAB 15	15.7	1.1	3.0	1.5	5	VSAB15NBR	VSAB15SI	VSAB15STN
VSAB 20	22	2.7	5.1	2.5	10	VSAB20NBR	VSAB20SI	VSAB20STN
VSAB 30	34	10	11.6	5.8	15	VSAB30NBR	VSAB30SI	VSAB30STN
VSAB 40	43	15	18.8	9.4	20	VSAB40NBR	VSAB40SI	VSAB40STN
VSAB 50	53	32	31.8	15.9	30	VSAB50NBR	VSAB50SI	VSAB50STN

(1) Actual force of the suction cup in use with a 65% vacuum and including a safety factor of 2 for horizontal handling and a factor of 4 for vertical handling.

Choice of Fittings

(Ø)	M5-M	G1/8"-M	G1/4"-M	G3/8"-M
5...15	■	-	-	-
20	-	■	-	-
30...50	-	-	■	■

■ Standard available configurations (suction cup + fitting) Fitting: M = male
See part n° table below

Type of Assembly

- C** **Version C: Barbed fitting**
- E** **Version E: Pressed fitting**

References - "Suction Cup + Fitting"

Ø	THREAD	C		E		
		M5-M	G1/8"-M	G1/4"-M	G3/8"-M	
Ø 5 - 15 mm	VSAB5NBR	VSAB5NBRIMM5C				
	VSAB5SI	VSAB5SIIMM5C				
	VSAB5STN	VSAB5STNIMM5C				
	VSAB8NBR	VSAB8NBRIMM5C				
	VSAB8SI	VSAB8SIIMM5C				
	VSAB8STN	VSAB8STNIMM5C				
	VSAB10NBR	VSAB10NBRIMM5C				
	VSAB10SI	VSAB10SIIMM5C				
	VSAB10STN	VSAB10STNIMM5C				
	VSAB15NBR	VSAB15NBRIMM5C				
	VSAB15SI	VSAB15SIIMM5C				
	VSAB15STN	VSAB15STNIMM5C				
Ø 20 mm	THREAD		G1/8"-M			
			Fitting with filter	Fitting without filter		
	VSAB20NBR	VSAB20NBRIM18MPF	VSAB20NBRIM18MP			
	VSAB20SI	VSAB20SIIM18MPF	VSAB20SIIM18MP			
	VSAB20STN	VSAB20STNIM18MPF	VSAB20STNIM18MP			
Ø 30 - 50 mm	THREAD		G1/4"-M		G3/8"-M	
			Fitting with filter	Fitting without filter	Fitting with filter	Fitting without filter
	VSAB30NBR	VSAB30NBRIM14MPF	VSAB30NBRIM14MP	VSAB30NBRIM38MPF	VSAB30NBRIM38MP	
	VSAB30SI	VSAB30SIIM14MPF	VSAB30SIIM14MP	VSAB30SIIM38MPF	VSAB30SIIM38MP	
	VSAB30STN	VSAB30STNIM14MPF	VSAB30STNIM14MP	VSAB30STNIM38MPF	VSAB30STNIM38MP	
	VSAB40NBR	VSAB40NBRIM14MPF	VSAB40NBRIM14MP	VSAB40NBRIM38MPF	VSAB40NBRIM38MP	
	VSAB40SI	VSAB40SIIM14MPF	VSAB40SIIM14MP	VSAB40SIIM38MPF	VSAB40SIIM38MP	
	VSAB40STN	VSAB40STNIM14MPF	VSAB40STNIM14MP	VSAB40STNIM38MPF	VSAB40STNIM38MP	
	VSAB50NBR	VSAB50NBRIM14MPF	VSAB50NBRIM14MP	VSAB50NBRIM38MPF	VSAB50NBRIM38MP	
	VSAB50SI	VSAB50SIIM14MPF	VSAB50SIIM14MP	VSAB50SIIM38MPF	VSAB50SIIM38MP	
	VSAB50STN	VSAB50STNIM14MPF	VSAB50STNIM14MP	VSAB50STNIM38MPF	VSAB50STNIM38MP	

Accessories

To optimize use of your suction cups, Coval offers a comprehensive range of accessories (sensors, spring extensions, and feeder systems, etc.) see chapters 4 and 14.



Please specify the part n°. e.g. **VSAB30NBRIM14MPF**
See part n° table above



Suction Cup + Fitting

VSAB 5...15

VSAB 20...30

VSAB 40

VSAB 50

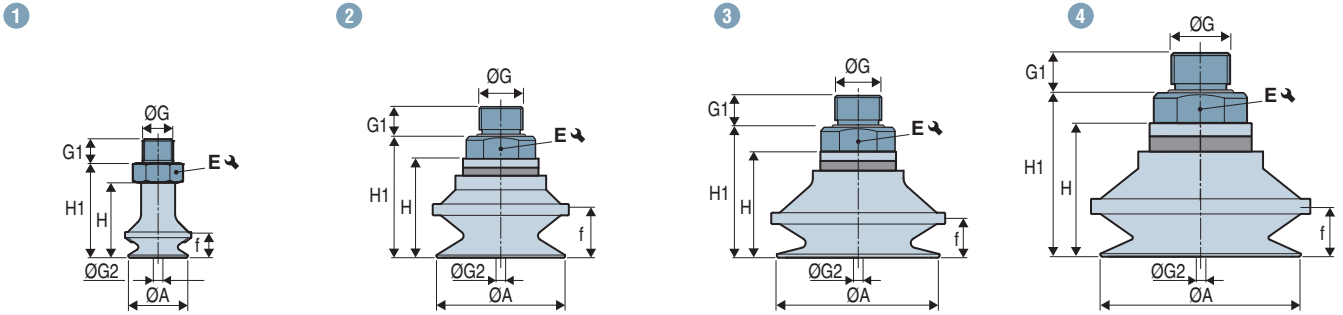

	Diagrams	ØA	f ⁽¹⁾	H	H1	ØG	G1	ØG2 ⁽²⁾	E ↘	⚖ (g)
VSAB5---IMM5C	1	5.6	1.5	9.2	12.7	M5-M	4	1.5	7	1.8
VSAB8---IMM5C	1	8.8	3.5	11.9	15.4	M5-M	4	1.5	7	2
VSAB10---IMM5C	1	11	4.5	16.4	20.9	M5-M	4	2.7	7	1.6
VSAB15---IMM5C	1	15.7	6.5	19.8	24.3	M5-M	4	2.7	7	2.1
VSAB20---IM18MP-	2	22	10	19	24	G1/8"-M	7	4	13	5.7
VSAB30---IM14MP-	2	34	15	26.2	32.2	G1/4"-M	9	5	19	13.9
VSAB30---IM38MP-	2	34	15	26.2	32.2	G3/8"-M	10	5	22	18.5
VSAB40---IM14MP-	3	43	15	28	34	G1/4"-M	9	5	19	19.6
VSAB40---IM38MP-	3	43	15	28	34	G3/8"-M	10	5	22	24.2
VSAB50---IM14MP-	4	53	13	35.3	41.3	G1/4"-M	9	6	22	33.8
VSAB50---IM38MP-	4	53	13	35.3	41.3	G3/8"-M	10	6	23.9	36.8

(1) f = Deflection of the suction cup. (2) Ø G2 = Ø internal orifice of the fitting.

Assembly Diagrams

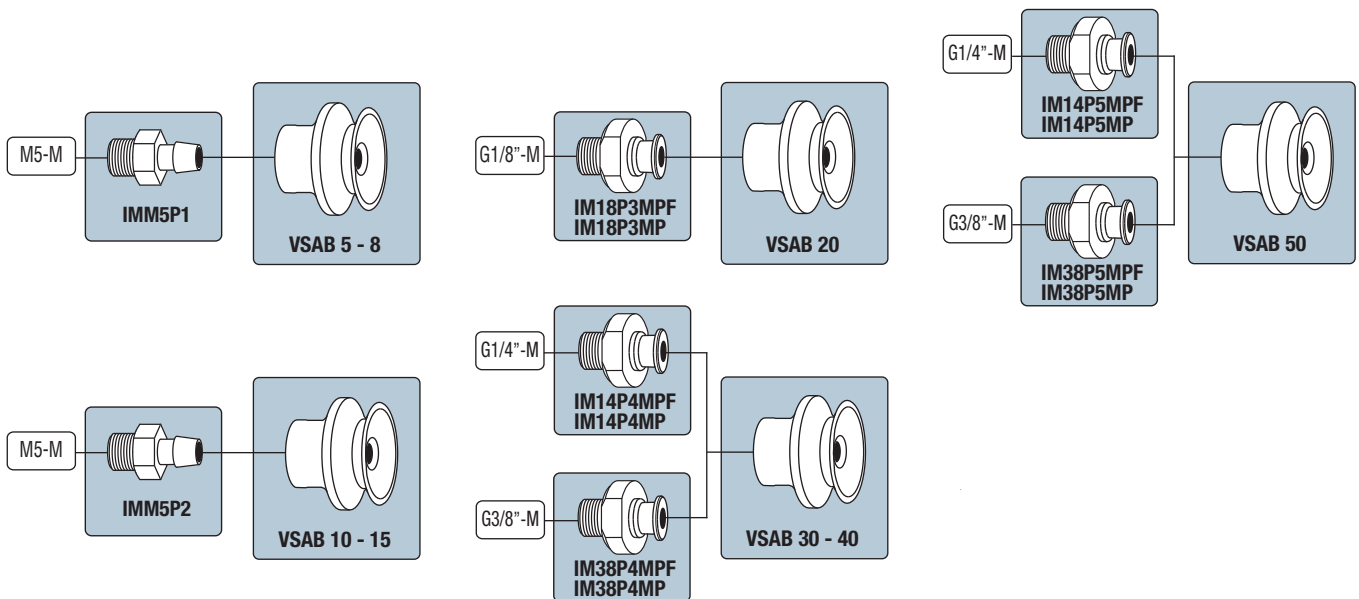

Note: All dimensions are in mm.

VSAB

Suction Cups with 1.5 Bellows Ø 5 to 50 mm

Dimensions



2 VSAB

Suction Cups

VSAB 5...15

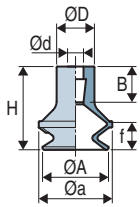

VSAB 20...30

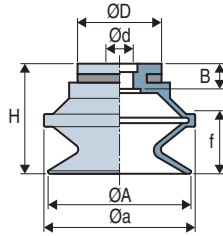

VSAB 40

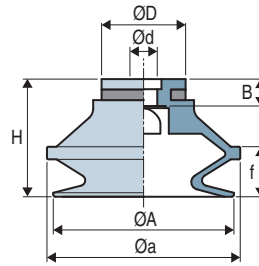

VSAB 50

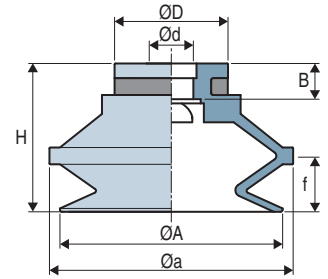

	ØA	H	Øa	Ød	ØD	f ⁽¹⁾	B	⚖ (g)
VSAB 5	5.6	9.2	6.2	2	4.5	1.5	5.8	0.12
VSAB 8	8.8	11.9	9.6	2	5.5	3.5	5.9	0.27
VSAB 10	11	16.4	12	3.8	9	4.5	8.5	0.8
VSAB 15	15.7	19.8	17.5	3.8	9	6.5	8.5	1.3
VSAB 20	22	19	24	5	14.5	10	4.5	2.5
VSAB 30	34	26.2	36	6.5	20	15	6	6.9
VSAB 40	43	28	46	6.5	20	15	6.4	12.6
VSAB 50	53	35.3	58	10.5	27	13	8.5	21.7

(1) f = Deflection of the suction cup. (2) Ø G2 = Ø internal orifice of the fitting.

Barbed Fittings

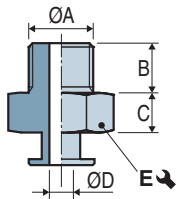

	ØA	B	C	ØD	E ↻	Material	⚖ (g)
IMM5P1	M5-M	4	3.5	1.5	7	Brass	1.7
IMM5P2	M5-M	4	4.5	2.7	7	Aluminum	0.8

Pressed fittings

Male fittings

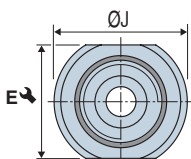
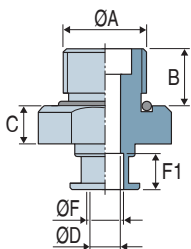

Fitting with stainless steel filter 200 µm	Fitting without filter	ØA	B	C	ØD	E ↻	ØJ	ØF	F1	Materials Fitting*	⚖ (g)
IM18P3MPF	IM18P3MP	G1/8"-M	7	5	4	13	15	5	4.7	Aluminum	3.2
IM14P4MPF	IM14P4MP	G1/4"-M	9	6	5	19	21	6	5.7	Aluminum	7
IM14P5MPF	IM14P5MP	G1/4"-M	9	6	6	22	28	10	8.7	Aluminum	12.1
IM38P4MPF	IM38P4MP	G3/8"-M	10	6	5	22	24	6	5.7	Aluminum	11.6
IM38P5MPF	IM38P5MP	G3/8"-M	10	6	6	23.9	28	10	8.7	Aluminum	15.1

*Male fittings (IM) equipped with O-ring sealing

Note: All dimensions are in mm.

The values represent the average characteristics of our products.

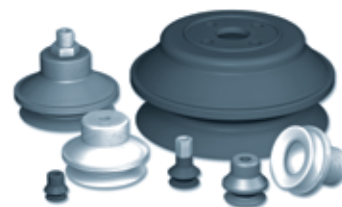

The VSAG series 1.5 bellows suction cups are recommended for gripping concave or convex products as well as sensitive products due to the cushioning effect of the bellows. The bellows also compensate for height variations in product gripping.

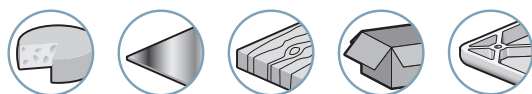

Industry-specific applications

Types of use



2

VSAG

Materials

- NBR** Nitrile
- SI** Translucent silicone
- STN** SITON®

Suction Cup Properties

	Ø (mm)	(cm ²)	(N) ⁽¹⁾	(N) ⁽¹⁾	(mm)	NBR	SI	STN
VSAG 10	10.7	0.2	1.8	0.9	4	VSAG10NBR	VSAG10SI	VSAG10STN
VSAG 15	15	0.7	2.5	1.3	6	VSAG15NBR	VSAG15SI	VSAG15STN
VSAG 20B	20	1	4.8	2.4	8	VSAG20BNBR	VSAG20BSI	VSAG20BSTN
VSAG 30	30	4	15.2	7.6	15	VSAG30NBR	VSAG30SI	-
VSAG 40	40	9	23.1	11.6	30	VSAG40NBR	VSAG40SI	-
VSAG 50	50	26	38.3	18.8	40	VSAG50NBR	VSAG50SI	-
VSAG 75	75	76	90.3	44.8	70	VSAG75NBR	VSAG75SI	VSAG75STN
VSAG 110	110	280	191.4	93.9	100	VSAG110NBR	VSAG110SI	VSAG110STN
VSAG 150	150	640	377.7	187.8	130	VSAG150NBR	VSAG150SI	-

(1) Actual force of the suction cup in use with a 65% vacuum and including a safety factor of 2 for horizontal handling and a factor of 4 for vertical handling.

Choice of Fittings

(Ø)	M5-F	M5-M	M6-M	M10-M	M10x125F	G1/8"-M	G1/8"-F	G1/4"-M	G1/4"-F	G1/2"-F
10...15	■	■	-	-	-	■	■	-	-	-
20...50	-	-	■	□	-	■	■	■	■	-
75	-	-	-	-	■	-	-	■	■	-
110...150	-	-	-	-	-	-	-	-	-	■

■ Standard available configurations (suction cup + fitting) refer to page 2/38

□ Additional mounting configurations see page 2/40

Fitting: M = male

F = female

Types of Assembly

COVAL suction cups can be assembled in a wide variety of configurations:



Version C
Barbed fitting



Version V
Removable fitting
(adapter and hollow screw)

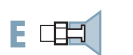

Version E
Pressed fitting



Please specify the part n°. e.g. VSAG10NBRIM18C
Refer to page 2/38

Accessories

To optimize use of your suction cups, Coval offers a comprehensive range of accessories (sensors, spring extensions, and feeder systems, etc.) see chapters 4 and 14.

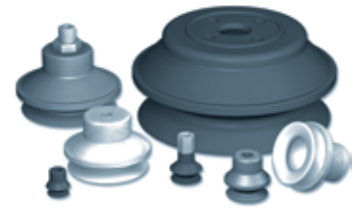

Ø 10 - 15 mm	THREAD	M5-M	M5-F	G1/8"-M	G1/8"-F
	VSAG10NBR	VSAG10NBRIMM5C	VSAG10NBRIFM5C	VSAG10NBRIM18C	VSAG10NBRIF18C
	VSAG10SI	VSAG10SIIMM5C	VSAG10SIIFM5C	VSAG10SIIM18C	VSAG10SIIF18C
	VSAG10STN	VSAG10STNIMM5C	VSAG10STNIFM5C	VSAG10STNIM18C	VSAG10STNIF18C
	VSAG15NBR	VSAG15NBRIMM5C	VSAG15NBRIFM5C	VSAG15NBRIM18C	VSAG15NBRIF18C
	VSAG15SI	VSAG15SIIMM5C	VSAG15SIIFM5C	VSAG15SIIM18C	VSAG15SIIF18C
	VSAG15STN	VSAG15STNIMM5C	VSAG15STNIFM5C	VSAG15STNIM18C	VSAG15STNIF18C



Ø 20 - 50 mm	THREAD	G1/8"-M	G1/8"-F	M6-M	G1/8"-M	G1/8"-F	G1/4"-M	G1/4"-F
	VSAG20BNBR	VSAG20BNBRIM18	VSAG20BNBRIF18	VSAG20BNBRIMM6V	VSAG20BNBRIM18V	VSAG20BNBRIF18V	VSAG20BNBRIM14V	VSAG20BNBRIF14V
	VSAG20BSI	VSAG20BSIIM18	VSAG20BSIIF18	VSAG20BSIIMM6V	VSAG20BSIIM18V	VSAG20BSIIF18V	VSAG20BSIIM14V	VSAG20BSIIF14V
	VSAG20BSTN	VSAG20BSTNIM18	VSAG20BSTNIF18	VSAG20BSTNIMM6V	VSAG20BSTNIM18V	VSAG20BSTNIF18V	VSAG20BSTNIM14V	VSAG20BSTNIF14V
	VSAG30NBR	VSAG30NBRIM18	VSAG30NBRIF18	VSAG30NBRIMM6V	VSAG30NBRIM18V	VSAG30NBRIF18V	VSAG30NBRIM14V	VSAG30NBRIF14V
	VSAG30SI	VSAG30SIIM18	VSAG30SIIF18	VSAG30SIIMM6V	VSAG30SIIM18V	VSAG30SIIF18V	VSAG30SIIM14V	VSAG30SIIF14V
	VSAG40NBR	VSAG40NBRIM18	VSAG40NBRIF18	VSAG40NBRIMM6V	VSAG40NBRIM18V	VSAG40NBRIF18V	VSAG40NBRIM14V	VSAG40NBRIF14V
	VSAG40SI	VSAG40SIIM18	VSAG40SIIF18	VSAG40SIIMM6V	VSAG40SIIM18V	VSAG40SIIF18V	VSAG40SIIM14V	VSAG40SIIF14V
	VSAG50NBR	-	-	VSAG50NBRIMM6V	VSAG50NBRIM18V	VSAG50NBRIF18V	VSAG50NBRIM14V	VSAG50NBRIF14V
	VSAG50SI	-	-	VSAG50SIIMM6V	VSAG50SIIM18V	VSAG50SIIF18V	VSAG50SIIM14V	VSAG50SIIF14V



Ø 75 mm	THREAD	M10x125 F	G1/4"-M	G1/4"-F
	VSAG75NBR	VSAG75NBR	VSAG75NBRIM14V	VSAG75NBRIF14V
	VSAG75SI	VSAG75SI	VSAG75SIIM14V	VSAG75SIIF14V
	VSAG75STN	VSAG75STN	VSAG75STNIM14V	VSAG75STNIF14V



Ø 110 - 150 mm	THREAD	G1/2"-F *	G1/2"-F **
	VSAG110NBR	VSAG110NBRIFS12V	VSAG110NBRIF12V
	VSAG110SI	VSAG110SIIFS12V	VSAG110SIIF12V
	VSAG110STN	VSAG110STNIFS12V	VSAG110STNIF12V
	VSAG150NBR	VSAG150NBRIFS12V	VSAG150NBRIF12V
	VSAG150SI	VSAG150SIIFS12V	VSAG150SIIF12V

*Configured using fitting n° IFS12120

** Configured using fitting n° IF12120

Additional mounting configurations are available (see page 2/40).
For standard configurations (suction cup+fitting), the C and V versions are delivered unassembled.



VSAG 10 - 15

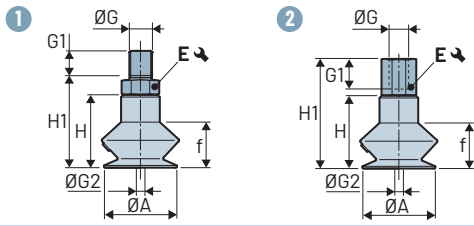

VSAG 20B - 50

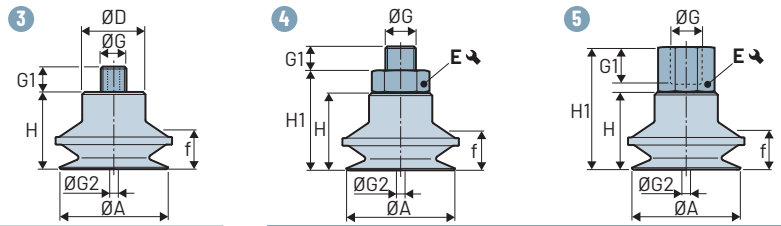

VSAG 75

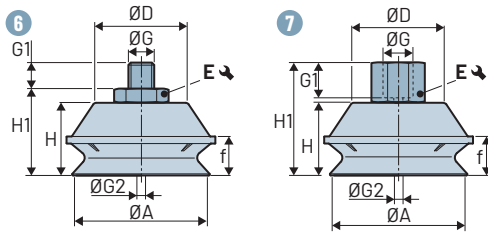

VSAG 110 - 150

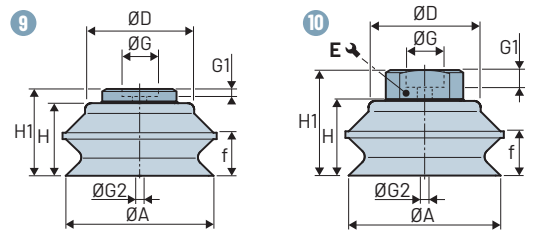

	Diagrams	Ø A	Ø D	f ⁽¹⁾	H	H1	Ø G	G1	Ø G2 ⁽²⁾	E ↘	⊖ (g)	
Ø 10 - 15 mm	VSAG10---IMM5C	1	10.7	-	5	13.3	16.8	M5-M	4.5	2.2	7	1.3
	VSAG10---IFM5C	2	10.7	-	5	13.3	22.3	M5-F	6	2.2	8	1.8
	VSAG10---IM18C	1	10.7	-	5	13.3	18.3	G1/8"-M	8	2.2	14	4.5
	VSAG10---IF18C	2	10.7	-	5	13.3	28.3	G1/8"-F	9	2.2	14	5.7
	VSAG15---IMM5C	1	15	-	10	16	19.5	M5-M	4.5	2.2	7	1.6
	VSAG15---IFM5C	2	15	-	10	16	25	M5-F	6	2.2	8	2.1
	VSAG15---IM18C	1	15	-	10	16	21	G1/8"-M	8	2.2	14	4.8
	VSAG15---IF18C	2	15	-	10	16	31	G1/8"-F	9	2.2	14	6
Ø 20 - 40 mm	VSAG20B---IM18	4	20	-	12	22	27	G1/8"-M	8	4	14	7.1
	VSAG20B---IF18	5	20	-	12	22	37	G1/8"-F	9	4	14	8.5
	VSAG20B---IMM6V	3	20	15	12	22	-	M6-M	6	3.5	-	5.7
	VSAG20B---IM18V	4	20	-	12	22	26.5	G1/8"-M	6	3.5	13	12.3
	VSAG20B---IF18V	5	20	-	12	22	35	G1/8"-F	7.5	3.5	13	15.6
	VSAG20B---IM14V	4	20	-	12	22	27	G1/4"-M	8	3.5	17	21.6
	VSAG20B---IF14V	5	20	-	12	22	38	G1/4"-F	11	3.5	17	26.2
	VSAG30---IM18	4	30	-	17	30.5	35.5	G1/8"-M	8	4	14	13.2
	VSAG30---IF18	5	30	-	17	30.5	45.5	G1/8"-F	9	4	14	14.6
	VSAG30---IMM6V	3	30	20	17	30.5	-	M6-M	6	3.5	-	11.8
	VSAG30---IM18V	4	30	-	17	30.5	35	G1/8"-M	6	3.5	13	18.4
	VSAG30---IF18V	5	30	-	17	30.5	43.5	G1/8"-F	7.5	3.5	13	21.7
	VSAG30---IM14V	4	30	-	17	30.5	35.5	G1/4"-M	8	3.5	17	27.7
	VSAG30---IF14V	5	30	-	17	30.5	46.5	G1/4"-F	11	3.5	17	32.3
	VSAG40---IM18	4	40	-	15.5	30.5	35.5	G1/8"-M	8	4	14	18.8
	VSAG40---IF18	5	40	-	15.5	30.5	45.5	G1/8"-F	9	4	14	20.2
	VSAG40---IMM6V	3	40	25	15.5	30.5	-	M6-M	6	3.5	-	17.4
	VSAG40---IM18V	4	40	-	15.5	30.5	35	G1/8"-M	6	3.5	13	24
	VSAG40---IF18V	5	40	-	15.5	30.5	43.5	G1/8"-F	7.5	3.5	13	27.3
	VSAG40---IM14V	4	40	-	15.5	30.5	35.5	G1/4"-M	8	3.5	17	33.3
VSAG40---IF14V	5	40	-	15.5	30.5	46.5	G1/4"-F	11	3.5	17	37.9	
Ø 50 mm	VSAG50---IMM6V	3	50	-	20	36.5	-	M6-M	6	3.5	-	30
	VSAG50---IM18V	4	50	-	20	36.5	41	G1/8"-M	6	3.5	13	36.6
	VSAG50---IF18V	5	50	-	20	36.5	49.5	G1/8"-F	7.5	3.5	13	40
	VSAG50---IM14V	4	50	-	20	36.5	41.5	G1/4"-M	8	3.5	17	45.9
	VSAG50---IM14F	5	50	-	20	36.5	52.5	G1/4"-F	11	3.5	17	50.4
Ø 75 - 150 mm	VSAG75---	8	75	50.5	22	43.2	-	M10x125-F	-	-	-	87.6
	VSAG75---IM14V	6	75	50.5	22	43.2	48.2	G1/4"-M	10	5	17	94.6
	VSAG75---IF14V	7	75	50.5	22	43.2	60.2	G1/4"-F	10	5	17	95.9
	VSAG110---IF12V	10	110	85	32.5	55	85	G1/2"-F	24	19	48	488.8
	VSAG110---IFS12V	9	110	85	32.5	55	68	G1/2"-F	13	-	-	407.5
	VSAG150---IF12V	10	150	120	39.5	75.5	105.5	G1/2"-F	24	19	48	911.4
	VSAG150---IFS12V	9	150	120	39.5	75.5	88.5	G1/2"-F	13	-	-	830.1

Note: All dimensions are in mm.

(1) f = Deflection of the suction cup. (2) Ø G2 = Ø internal orifice of the fitting.

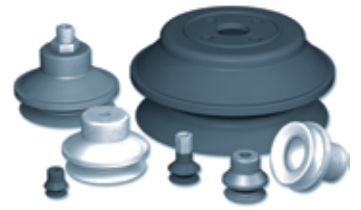

VSAG 10 - 15

Barbed fittings **C**

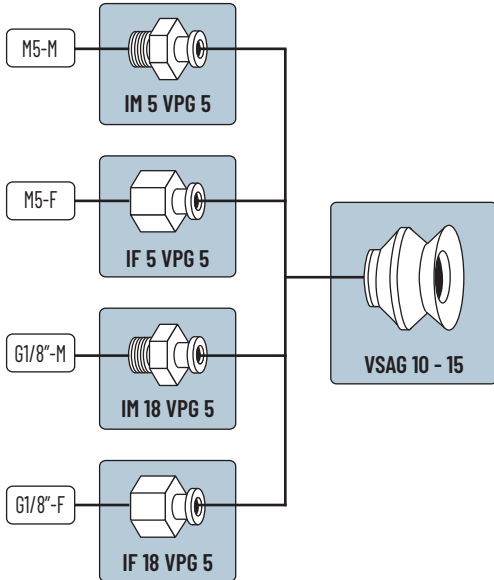

VSAG 20B - 40

Pressed fittings **E**

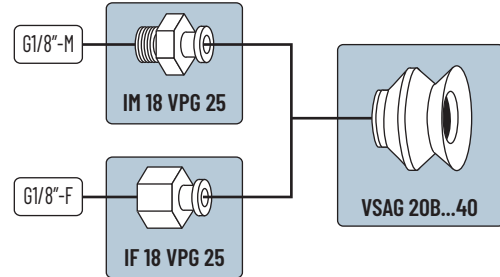

VSAG 20B - 50

Removable fittings **V**

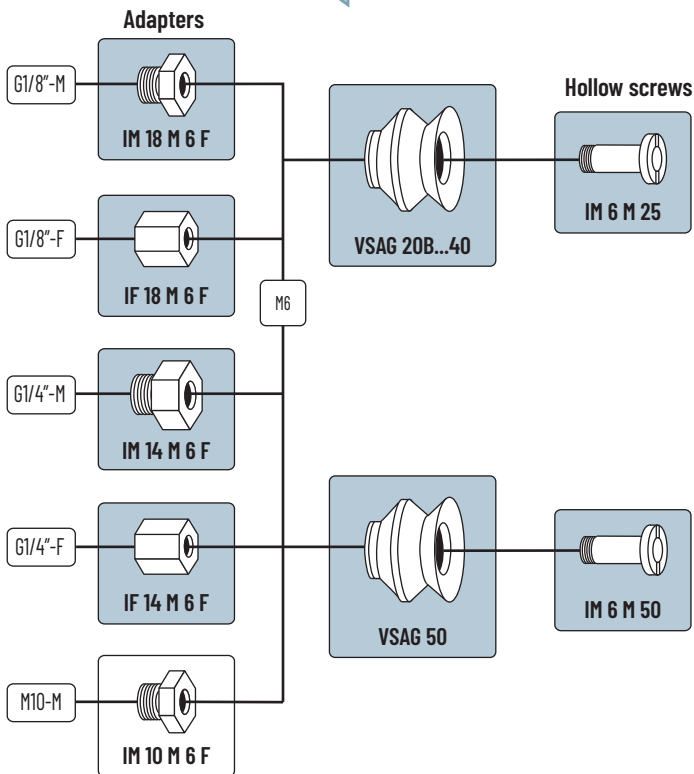

VSAG 75 - 150

Removable fittings **V**

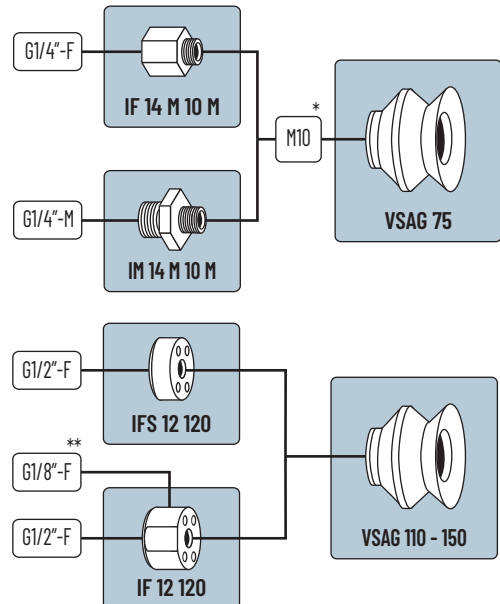

* 125 thread

** Female auxiliary radial output

- Configurations (suction cup + fitting) refer to page 2/38
- Non-standard configurations must be ordered in separate part numbers.

Fittings and suction cups dimensions:
see pages 2/41 and 2/42.

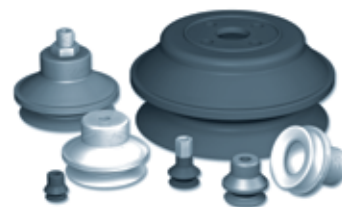

VSAG 10 - 15

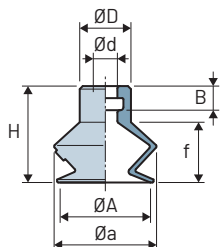

VSAG 20 - 50

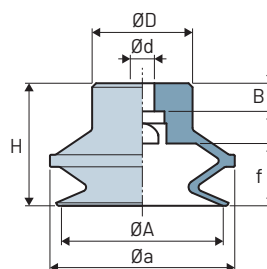

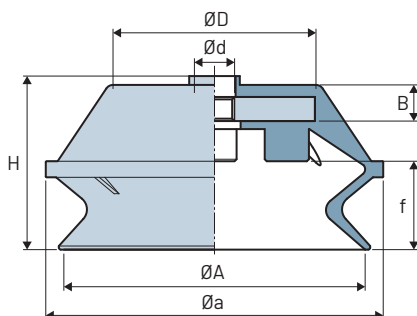

VSAG 75

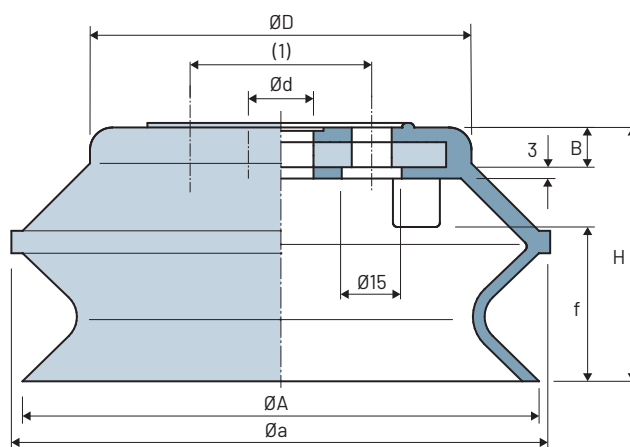

VSAG 110 - 150



(1) 4 holes \varnothing 9 on \varnothing 40

 (\varnothing)	$\varnothing A$	H	$\varnothing a$	$\varnothing d$	$\varnothing D$	f ⁽¹⁾	B	 (g)
VSAG 10	10.7	13.3	12.5	4	8.5	5	4	0.6
VSAG 15	15	16	17	4	8.5	10	4	0.9
VSAG 20 B	20	22	24	6	15	12	7	3
VSAG 30	30	30.5	36	6	20	17	7	9.1
VSAG 40	40	30.5	46	6	25	15.5	7	14.7
VSAG 50	50	36.5	59.5	7.8	28.5	20	7	22.5
VSAG 75	75	43.2	84	M10 x 125 - F	50.5	22	9	87.6
VSAG 110	110	55	121.5	14	85	32.5	9	264
VSAG 150	150	75.5	166	13	120	39.5	11	686.6

The values represent the average characteristics of our products.
Note: All dimensions are in mm.

(1) f = Deflection of the suction cup.

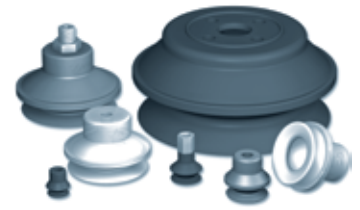

Barbed fittings

Male - IM

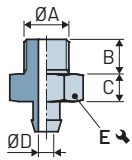

Female - IF

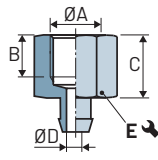

	ØA	B	C	ØD	E ↘	Material	⚖ (g)
IM 5 VPG5	M5-M	4.5	3.5	2.2	7	Aluminum	0.7
IM 18 VPG5	G1/8"-M	8	5	2.2	14	Aluminum	3.9
IF 5 VPG5	M5-F	6	9	2.2	8	Aluminum	1.2
IF 18 VPG5	G1/8"-F	9	15	2.2	14	Aluminum	5.1

Pressed Fittings

Male - IM

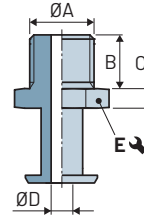

Female - IF

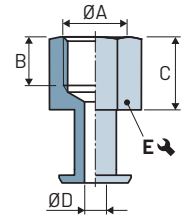

	ØA	B	C	ØD	E ↘	Material	⚖ (g)
IM 18 VPG25	G1/8"-M	8	5	4	14	Aluminum	4.08
IF 18 VPG25	G1/8"-F	9	15	4	14	Aluminum	5.5

Hollow Screws

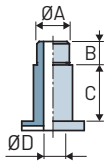

	ØA	B	C	ØD	Material	⚖ (g)
IM 6 M25	M6-M	6	6	3.5	Nickel-plated brass	2.7
IM 6 M50	M6-M	6	6	3.5	Nickel-plated brass	7.5

Adapters for Hollow Screws

Male - IM

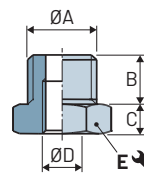

Female - IF

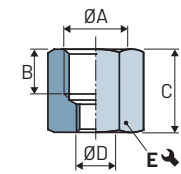

	ØA	B	C	ØD	E ↘	Material	⚖ (g)
IM 10 M6F	M10-M	7	3.5	M6	13	Brass	5.9
IM 14 M6F	G1/4"-M	8	5	M6-F	17	Nickel-plated brass	15.9
IM 18 M6F	G1/8"-M	6	4.5	M6-F	13	Nickel-plated brass	6.6
IF 14 M6F	G1/4"-F	11	16	M6-F	17	Nickel-plated brass	20.5
IF 18 M6F	G1/8"-F	7.5	13	M6-F	13	Nickel-plated brass	9.9

Removable Fittings

Male - IM

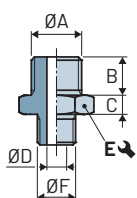

Female - IF

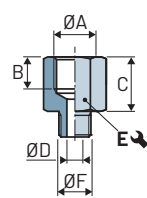

Female - IF 12120

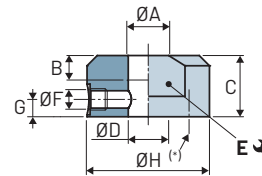

Female - IFS 12120

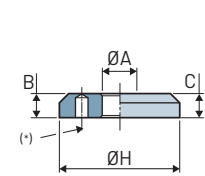

(1) 4 holes Ø 9 on Ø 40

	ØA	B	C	ØD	E ↘	ØF	G	H	Material	⚖ (g)
IM 14 M10M	G1/4"-M	10	5	5	17	M10x125-M	-	-	Aluminum	7
IF 14 M10M	G1/4"-F	10	17	5	17	M10x125-M	-	-	Aluminum	8.3
IF 12120	G1/2"-F	24	30	19	48	G1/8"-F	8.7	60	Aluminum	224.8
IFS 12120	G1/2"-F	13	13	-	-	-	-	65	Aluminum	143.5

The values represent the average characteristics of our products.
Note: All dimensions are in mm.

VSAJ

Suction Cups with 1.5 Bellows Ø 15 to 30 mm



Industry-specific applications

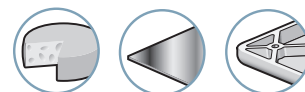

Types of use



The VSAJ series 1.5 bellows suction cups are recommended to grip slightly convex or concave products. They are also able to compensate for height variations in products being gripped.





Materials

NBR Nitrile
SI Translucent silicone

2

VSAJ

Suction Cup Properties

	Ø (mm)	 (cm ³)	 (N) ⁽¹⁾	 (N) ⁽¹⁾	 (mm)	NBR	SI
VSAJ 15	15	0.5	3.6	1.8	10	VSAJ15NBR	VSAJ15SI
VSAJ 20	20	1.2	6.9	3.4	13	VSAJ20NBR	VSAJ20SI
VSAJ 30	30	3	13.4	6.6	26	VSAJ30NBR	VSAJ30SI

(1) Actual force of the suction cup in use with 65% vacuum and including a safety factor of 2 for horizontal handling and a factor of 4 for vertical handling.

Choice of Fittings

 (Ø)	M5-M	M6-M	M10-M	G1/8"-F	G1/8"-M	G1/4"-F	G1/4"-M
15...20	■	-	-	■	■	-	-
30	-	■	□	■	■	■	■

■ Standard available configurations (suction cup + fitting) □ Additional mounting configurations refer to page 2/44 see page 2/45

Fitting: M = male F = female

Types of Assembly

COVAL suction cups can be assembled in a wide variety of configurations:

C  **Version C**
Barbed fitting

V  **Version V**
Removable fitting
(adaptor and hollow screw)

E  **Version E**
Pressed fitting



Please specify the part n°. e.g. VSAJ20NBRIM18C
Refer to page 2/44

Accessories

To optimize use of your suction cups, Coval offers a comprehensive range of accessories (spring systems, extensions, feeder systems, etc.) see chapters 4 and 14.

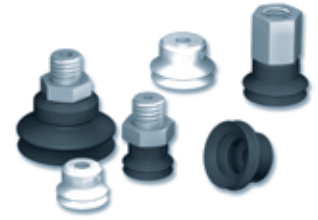

References - "Suction Cup + Fitting"

Ø 15 - 20 mm	C			V		
	THREAD	G1/8"-M	G1/8"-F	M5-M	G1/8"-M	G1/8"-F
VSAJ15NBR	VSAJ15NBRIM18C	VSAJ15NBRIF18C	VSAJ15NBRIMM5V	VSAJ15NBRIM18V	VSAJ15NBRIF18V	
VSAJ15SI	VSAJ15SIIM18C	VSAJ15SIIF18C	VSAJ15SIIMM5V	VSAJ15SIIM18V	VSAJ15SIIF18V	
VSAJ20NBR	-	-	VSAJ20NBRIMM5V	VSAJ20NBRIM18V	VSAJ20NBRIF18V	
VSAJ20SI	-	-	VSAJ20SIIMM5V	VSAJ20SIIM18V	VSAJ20SIIF18V	

Ø 30 mm	E			V			
	THREAD	G1/8"-M	G1/8"-F	M5-M	G1/8"-M	G1/8"-F	G1/4"-M
VSAJ30NBR	VSAJ30NBRIM18	VSAJ30NBRIF18	VSAJ30NBRIMM6V	VSAJ30NBRIM18V	VSAJ30NBRIF18V	VSAJ30NBRIM14V	VSAJ30NBRIF14V
VSAJ30SI	VSAJ30SIIM18	VSAJ30SIIF18	VSAJ30SIIMM6V	VSAJ30SIIM18V	VSAJ30SIIF18V	VSAJ30SIIM14V	VSAJ30SIIF14V

VSAJ 15 - 20

VSAJ 30

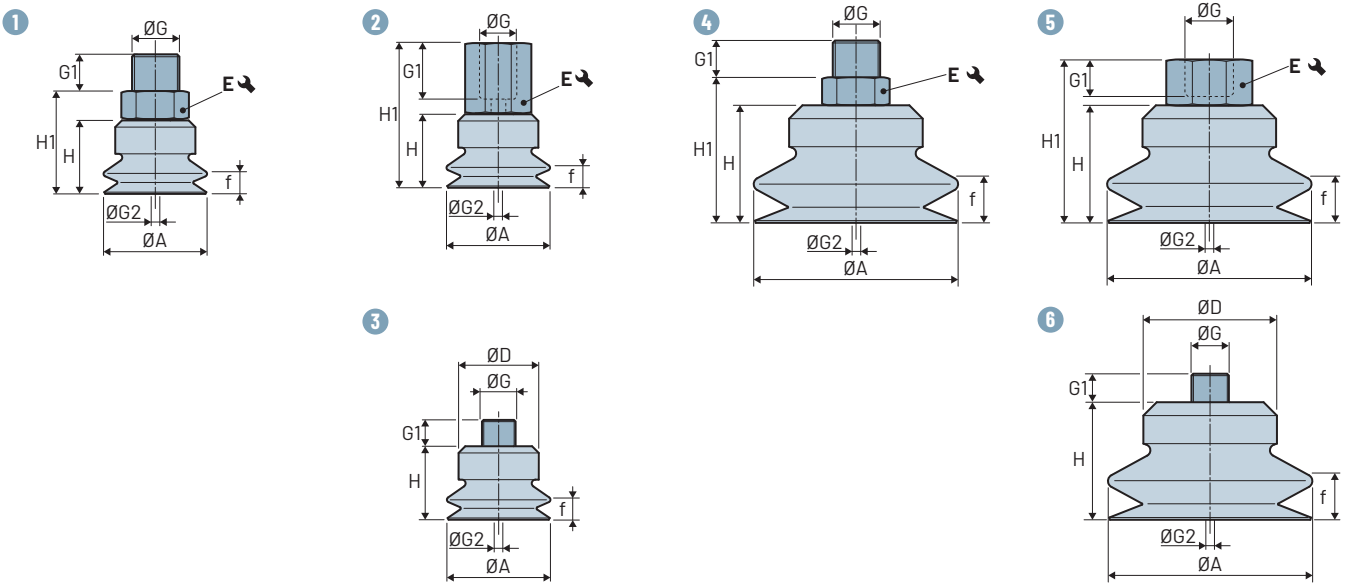

	Diagrams	Ø A	Ø D	f ⁽¹⁾	H	H1	Ø G	G1	Ø G2 ⁽²⁾	E	(g)	
Ø 15 - 20 mm	VSAJ15---IM18C	1	15	-	3.3	11	16	G1/8"-M	8	2.2	14	4.8
	VSAJ15---IF18C	2	15	-	3.3	11	26	G1/8"-F	9	2.5	14	6
	VSAJ15---IMM5V	3	15	12	3.3	11	-	M5-M	5	2.5	-	3
	VSAJ15---IM18V	1	15	-	3.3	11	15.5	G1/8"-M	6	2.5	13	9.4
	VSAJ15---IF18V	2	15	-	3.3	11	24	G1/8"-F	7.5	2.5	13	12.6
	VSAJ20---IMM5V	3	20	15	5.5	13	-	M5-M	5	2.5	-	3.8
	VSAJ20---IM18V	1	20	-	5.5	13	17.5	G1/8"-M	6	2.5	13	10.1
VSAJ20---IF18V	2	20	-	5.5	13	26	G1/8"-F	7.5	2.5	13	14.6	
Ø 30 mm	VSAJ30---IM18	4	30	-	7	17	42	G1/8"-M	8	4	14	9
	VSAJ30---IF18	5	30	-	7	17	32	G1/8"-F	9	4	14	8.4
	VSAJ30---IMM6V	6	30	20	7	17	-	M6-M	6	3.5	-	7.6
	VSAJ30---IM18V	4	30	-	7	17	21.5	G1/8"-M	6	3.5	13	14.2
	VSAJ30---IF18V	5	30	-	7	17	30	G1/8"-F	7.5	3.5	13	17.5
	VSAJ30---IM14V	4	30	-	7	17	21.5	G1/4"-M	8	3.5	17	20.8
VSAJ30---IF14V	5	30	-	7	17	33	G1/4"-F	11	3.5	17	28.1	

Note: All dimensions are in mm.

(1) f = Deflection of the suction cup.

(2) Ø G2 = Ø internal orifice of the fitting.

Additional mounting configurations are available (see page 2/45). For standard configurations (suction cup+fitting), the C and V versions are delivered unassembled.

VSAJ

Suction Cups with 1.5 Bellows Ø 15 to 30 mm Assembly Diagrams

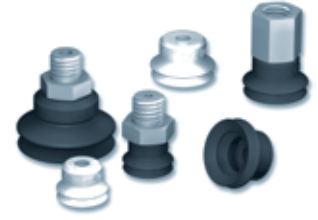

2
VSAJ

VSAJ 15 - 20

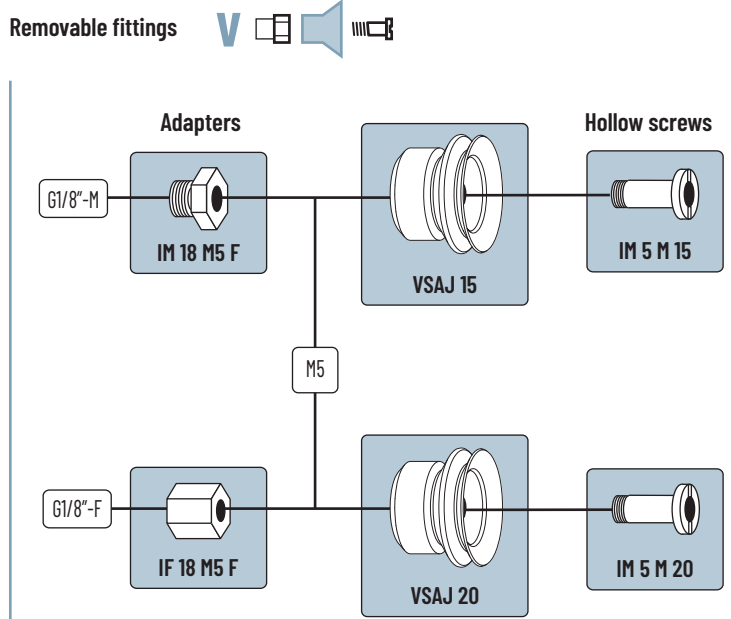
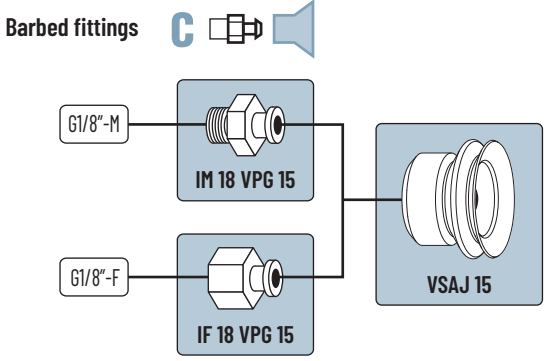

VSAJ 30

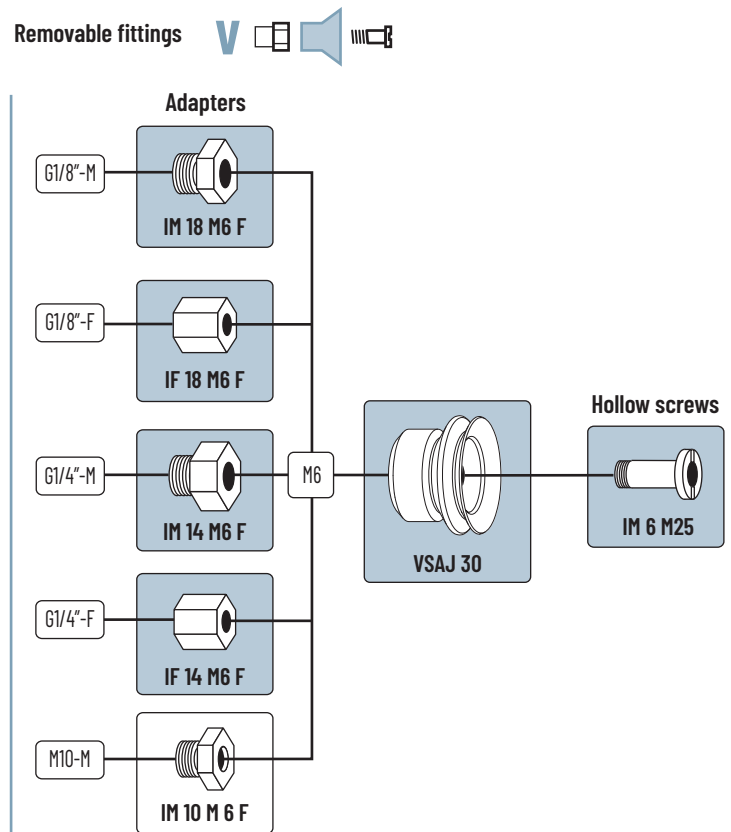
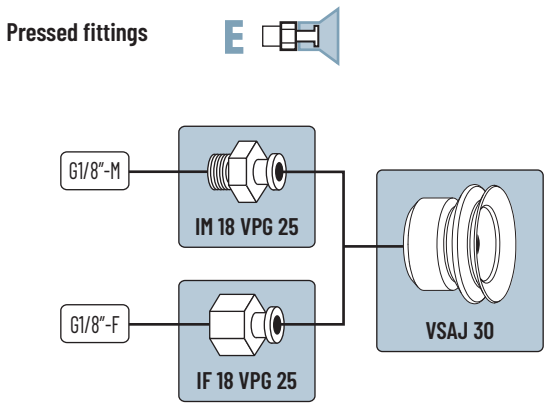

- Configurations (suction cup + fitting) refer to page 2/44
- Non-standard configurations must be ordered in separate part numbers.

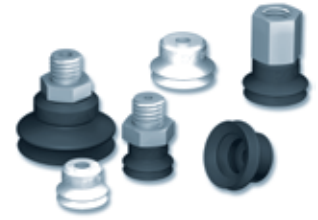

Suction Cups

VSAJ 15

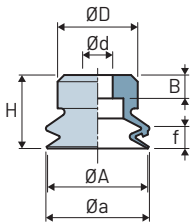

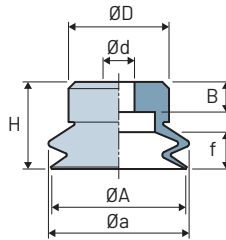

VSAJ 20

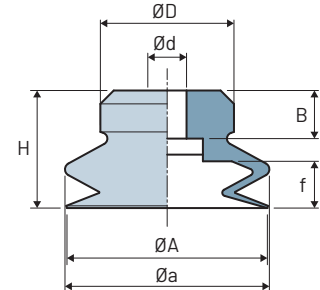

VSAJ 30



	Ø A	H	Ø a	Ø d	Ø D	f ⁽¹⁾	B	 (g)
VSAJ 15	15	11	15.5	4.5	12	3.3	3.5	9
VSAJ 20	20	13	21	4.7	15	5.5	4.5	8.4
VSAJ 30	30	17	30.6	5.8	20	7	7.2	7.6

(1) f = Deflection of the suction cup.

Barbed Fittings

Male - IM

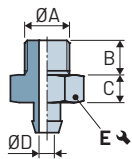

Female - IF

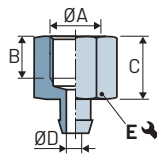

	Ø A	B	C	Ø D	E	Material	 (g)
IM 18 VPG15	G1/8"-M	8	5	2.2	14	Aluminum	4
IF 18 VPG15	G1/8"-F	9	15	2.5	14	Aluminum	5.2

Pressed Fittings

Male - IM

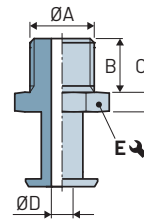

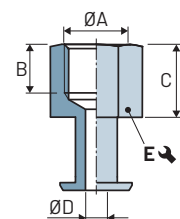

Female - IF

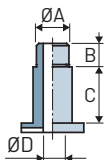

	Ø A	B	C	Ø D	E	Material	 (g)
IM 18 VPG25	G1/8"-M	8	5	4	14	Aluminum	4.08
IF 18 VPG25	G1/8"-F	9	15	4	14	Aluminum	5.5

Hollow Screws



	Ø A	B	C	Ø D	Material	 (g)
IM 5 M15	M5-M	5	2	2.5	Nickel-plated brass	1.3
IM 5 M20	M5-M	5	4	2.5	Nickel-plated brass	2.2
IM 6 M25	M6-M	6	6	3.5	Nickel-plated brass	2.7

Adapters for Hollow Screws

Male - IM

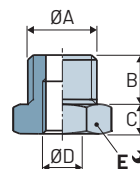

Female - IF

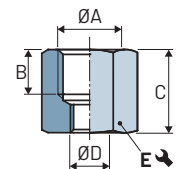

	Ø A	B	C	Ø D	E	Material	 (g)
IM 10 M6F	M10-M	7	3.5	M6-F	13	Brass	5.9
IM 14 M6F	G1/4"-M	8	5	M6-F	17	Nickel-plated brass	15.9
IM 18 M5F	G1/8"-M	6	4.5	M5-F	13	Nickel-plated brass	7.3
IM 18 M6F	G1/8"-M	6	4.5	M6-F	13	Nickel-plated brass	6.6
IF 14 M6F	G1/4"-F	11	16	M6-F	17	Nickel-plated brass	20.5
IF 18 M5F	G1/8"-F	7.5	13	M5-F	13	Nickel-plated brass	10.5
IF 18 M6F	G1/8"-F	7.5	13	M6-F	13	Nickel-plated brass	9.9

The values represent the average characteristics of our products.
Note: All dimensions are in mm.

VS

Suction Cups with 2.5 Bellows Ø 5 to 88 mm



VS series suction cups with bellows are recommended for gripping products on different planes (wide deflection) where they can replace spring systems, and for gripping spherical or cylindrical objects gripped at an angle (ball-joint effect).

- Large deflection (stroke)
- Flexibility

Materials

NBR Nitrile
NR Natural rubber

SIT5 Translucent silicone
STN SITON® 60 ShoreA
STN5 SITON® 50 ShoreA (on request)

Industry-specific applications

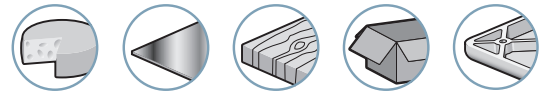

Types of use



2 VS

Suction Cup Properties

	Ø (mm)	Volume (cm³)	Force (N) ⁽¹⁾	R _{min} (mm)	NBR	SIT5	NR	STN ⁽²⁾
VS 5	5	0.04	0.5	8	VS5NBR	VS5SIT5	-	VS5STN
VS 6	6	0.04	0.5	8	VS6NBR	VS6SIT5	-	-
VS 7	7	0.0425	0.9	8	VS7NBR	VS7SIT5	-	VS7STN
VS 9	9	0.15	1.1	10	VS9NBR	VS9SIT5	VS9NR	VS9STN
VS 12	12	0.54	2.8	13	VS12NBR	VS12SIT5	VS12NR	VS12STN
VS 14	14	0.975	3.0	15	VS14NBR	VS14SIT5	VS14NR	VS14STN
VS 18	17.5	1.35	4.4	20	VS18NBR	VS18SIT5	VS18NR	VS18STN
VS 20	20	2	4.6	30	VS20NBR	VS20SIT5	VS20NR	VS20STN
VS 25	25	5.4	6.5	30	VS25NBR	VS25SIT5	VS25NR	VS25STN
VS 26	25	6.1	10.8	30	VS26NBR	VS26SIT5	VS26NR	VS26STN
VS 32	32	10	12.1	35	VS32NBR	VS32SIT5	VS32NR	VS32STN
VS 42	42	19.5	20.9	75	VS42NBR	VS42SIT5	VS42NR	VS42STN
VS 52	52	36	28.9	75	VS52NBR	VS52SIT5	VS52NR	VS52STN
VS 62	62	72.5	41.2	75	VS62NBR	VS62SIT5	VS62NR	VS62STN
VS 88	88	165	132.9	100	VS88NBR	VS88SIT5	VS88NR	-

(1) Actual force of the suction cup in use with 65% vacuum and including a safety factor of 2 for horizontal handling.

(2) On request, some models are available in STN5 (SITON® 50 ShoreA)

Choice of Fittings

(Ø)	Group	M3-M	M5-M	M6-M	M8-M	M10-M	G1/8"-F	G1/8"-M	10/32-M	G1/4"-F	G1/4"-M	G3/8"-M	G1/2"-M
5 - 6	1	■	-	-	-	-	-	-	-	-	-	-	-
7 - 25	1	-	■	■	-	-	■	■	□	-	-	-	-
26 - 62	2	-	□	□	□	□	■	■	-	■	■	-	-
88	3	-	-	-	-	□	-	■	-	■	■	■	□

■ Standard available configurations (suction cup + fitting) refer to page 2/48
□ Additional mounting configurations see page 2/51

Fitting: M = male F = female

Types of Assembly

COVAL suction cups can be assembled in a wide variety of configurations.

- C** **Version C** Barbed fitting
- S** **Version S** Factory-crimped fitting
- V** **Version V** Removable fitting: (adapter and hollow screw)
- E** **Version E** Pressed fitting

Textured Surfaces

For handling objects with a granular or textured gripping surface, use VS suction cups with the VSBM foam strip option (see page 2/65).

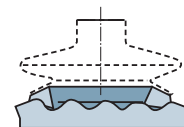

Please specify the part n°. e.g. VS32SIT5IF14
Refer to page 2/48

Accessories

To optimize the use of your suction cups, Coval offers a comprehensive range of accessories (nozzle fittings, spring extensions, and feeder systems, etc.), see chapters 4 and 14.

VS

Suction Cups with 2.5 Bellows Ø 5 to 88 mm

References - "Suction Cup + Fitting"



VS 2

Group 1		C				
Ø 5 - 25 mm	THREAD	M3M	M5M	M6M	G1/8"-M	G1/8"-F
	VS5NBR	VS5NBRIMM3C	-	-	-	-
VS5SIT5	VS5SIT5IMM3C	-	-	-	-	-
VS5STN	VS5STNIMM3C	-	-	-	-	-
VS6NBR	VS6NBRIMM3C	-	-	-	-	-
VS6SIT5	VS6SIT5IMM3C	-	-	-	-	-
VS7NBR	-	VS7NBRIMM5C	VS7NBRIMM6C	VS7NBRIM18C	VS7NBRIF18C	
VS7SIT5	-	VS7SIT5IMM5C	VS7SIT5IMM6C	VS7SIT5IM18C	VS7SIT5IF18C	
VS7STN	-	VS7STNIMM5C	VS7STNIMM6C	VS7STNIM18C	VS7STNIF18C	
VS9NBR	-	VS9NBRIMM5C	VS9NBRIMM6C	VS9NBRIM18C	VS9NBRIF18C	
VS9SIT5	-	VS9SIT5IMM5C	VS9SIT5IMM6C	VS9SIT5IM18C	VS9SIT5IF18C	
VS9NR	-	VS9NRIMM5C	VS9NRIMM6C	VS9NRIM18C	VS9NRIF18C	
VS9STN	-	VS9STNIMM5C	VS9STNIMM6C	VS9STNIM18C	VS9STNIF18C	
VS12NBR	-	VS12NBRIMM5C	VS12NBRIMM6C	VS12NBRIM18C	VS12NBRIF18C	
VS12SIT5	-	VS12SIT5IMM5C	VS12SIT5IMM6C	VS12SIT5IM18C	VS12SIT5IF18C	
VS12NR	-	VS12NRIMM5C	VS12NRIMM6C	VS12NRIM18C	VS12NRIF18C	
VS12STN	-	VS12STNIMM5C	VS12STNIMM6C	VS12STNIM18C	VS12STNIF18C	
VS14NBR	-	VS14NBRIMM5C	VS14NBRIMM6C	VS14NBRIM18C	VS14NBRIF18C	
VS14SIT5	-	VS14SIT5IMM5C	VS14SIT5IMM6C	VS14SIT5IM18C	VS14SIT5IF18C	
VS14NR	-	VS14NRIMM5C	VS14NRIMM6C	VS14NRIM18C	VS14NRIF18C	
VS14STN	-	VS14STNIMM5C	VS14STNIMM6C	VS14STNIM18C	VS14STNIF18C	
VS18NBR	-	VS18NBRIMM5C	VS18NBRIMM6C	VS18NBRIM18C	VS18NBRIF18C	
VS18SIT5	-	VS18SIT5IMM5C	VS18SIT5IMM6C	VS18SIT5IM18C	VS18SIT5IF18C	
VS18NR	-	VS18NRIMM5C	VS18NRIMM6C	VS18NRIM18C	VS18NRIF18C	
VS18STN	-	VS18STNIMM5C	VS18STNIMM6C	VS18STNIM18C	VS18STNIF18C	
VS20NBR	-	VS20NBRIMM5C	VS20NBRIMM6C	VS20NBRIM18C	VS20NBRIF18C	
VS20SIT5	-	VS20SIT5IMM5C	VS20SIT5IMM6C	VS20SIT5IM18C	VS20SIT5IF18C	
VS20NR	-	VS20NRIMM5C	VS20NRIMM6C	VS20NRIM18C	VS20NRIF18C	
VS20STN	-	VS20STNIMM5C	VS20STNIMM6C	VS20STNIM18C	VS20STNIF18C	
VS25NBR	-	VS25NBRIMM5C	VS25NBRIMM6C	VS25NBRIM18C	VS25NBRIF18C	
VS25SIT5	-	VS25SIT5IMM5C	VS25SIT5IMM6C	VS25SIT5IM18C	VS25SIT5IF18C	
VS25NR	-	VS25NRIMM5C	VS25NRIMM6C	VS25NRIM18C	VS25NRIF18C	
VS25STN	-	VS25STNIMM5C	VS25STNIMM6C	VS25STNIM18C	VS25STNIF18C	

Additional mounting configurations are available (see page 2/51).
For standard configurations (suction cup+fitting), the C and V versions are delivered unassembled.

Group 2		C		E		V			
Ø 26 - 62 mm	THREAD	G1/4"-M	G1/4"-F	G1/4"-M	G1/4"-F	G1/8"-M	G1/8"-F	G1/4"-M	G1/4"-F
	VS26NBR	VS26NBRIM14C	VS26NBRIF14C	VS26NBRIM14	VS26NBRIF14	VS26NBRIM18V	VS26NBRIF18V	VS26NBRIM14V	VS26NBRIF14V
VS26SIT5	VS26SIT5IM14C	VS26SIT5IF14C	VS26SIT5IM14	VS26SIT5IF14	VS26SIT5IM18V	VS26SIT5IF18V	VS26SIT5IM14V	VS26SIT5IF14V	
VS26NR	VS26NRIM14C	VS26NRIF14C	VS26NRIM14	VS26NRIF14	VS26NRIM18V	VS26NRIF18V	VS26NRIM14V	VS26NRIF14V	
VS26STN	VS26STNIM14C	VS26STNIF14C	VS26STNIM14	VS26STNIF14	VS26STNIM18V	VS26STNIF18V	VS26STNIM14V	VS26STNIF14V	
VS32NBR	VS32NBRIM14C	VS32NBRIF14C	VS32NBRIM14	VS32NBRIF14	VS32NBRIM18V	VS32NBRIF18V	VS32NBRIM14V	VS32NBRIF14V	
VS32SIT5	VS32SIT5IM14C	VS32SIT5IF14C	VS32SIT5IM14	VS32SIT5IF14	VS32SIT5IM18V	VS32SIT5IF18V	VS32SIT5IM14V	VS32SIT5IF14V	
VS32NR	VS32NRIM14C	VS32NRIF14C	VS32NRIM14	VS32NRIF14	VS32NRIM18V	VS32NRIF18V	VS32NRIM14V	VS32NRIF14V	
VS32STN	VS32STNIM14C	VS32STNIF14C	VS32STNIM14	VS32STNIF14	VS32STNIM18V	VS32STNIF18V	VS32STNIM14V	VS32STNIF14V	
VS42NBR	VS42NBRIM14C	VS42NBRIF14C	VS42NBRIM14	VS42NBRIF14	VS42NBRIM18V	VS42NBRIF18V	VS42NBRIM14V	VS42NBRIF14V	
VS42SIT5	VS42SIT5IM14C	VS42SIT5IF14C	VS42SIT5IM14	VS42SIT5IF14	VS42SIT5IM18V	VS42SIT5IF18V	VS42SIT5IM14V	VS42SIT5IF14V	
VS42NR	VS42NRIM14C	VS42NRIF14C	VS42NRIM14	VS42NRIF14	VS42NRIM18V	VS42NRIF18V	VS42NRIM14V	VS42NRIF14V	
VS42STN	VS42STNIM14C	VS42STNIF14C	VS42STNIM14	VS42STNIF14	VS42STNIM18V	VS42STNIF18V	VS42STNIM14V	VS42STNIF14V	
VS52NBR	VS52NBRIM14C	VS52NBRIF14C	VS52NBRIM14	VS52NBRIF14	VS52NBRIM18V	VS52NBRIF18V	VS52NBRIM14V	VS52NBRIF14V	
VS52SIT5	VS52SIT5IM14C	VS52SIT5IF14C	VS52SIT5IM14	VS52SIT5IF14	VS52SIT5IM18V	VS52SIT5IF18V	VS52SIT5IM14V	VS52SIT5IF14V	
VS52NR	VS52NRIM14C	VS52NRIF14C	VS52NRIM14	VS52NRIF14	VS52NRIM18V	VS52NRIF18V	VS52NRIM14V	VS52NRIF14V	
VS52STN	VS52STNIM14C	VS52STNIF14C	VS52STNIM14	VS52STNIF14	VS52STNIM18V	VS52STNIF18V	VS52STNIM14V	VS52STNIF14V	
VS62NBR	VS62NBRIM14C	VS62NBRIF14C	VS62NBRIM14	VS62NBRIF14	VS62NBRIM18V	VS62NBRIF18V	VS62NBRIM14V	VS62NBRIF14V	
VS62SIT5	VS62SIT5IM14C	VS62SIT5IF14C	VS62SIT5IM14	VS62SIT5IF14	VS62SIT5IM18V	VS62SIT5IF18V	VS62SIT5IM14V	VS62SIT5IF14V	
VS62NR	VS62NRIM14C	VS62NRIF14C	VS62NRIM14	VS62NRIF14	VS62NRIM18V	VS62NRIF18V	VS62NRIM14V	VS62NRIF14V	
VS62STN	VS62STNIM14C	VS62STNIF14C	VS62STNIM14	VS62STNIF14	VS62STNIM18V	VS62STNIF18V	VS62STNIM14V	VS62STNIF14V	

Group 3		V			S	
Ø 88 mm	THREAD	G1/8"-M	G1/4"-M	G1/4"-F	G1/4"-M	G3/8"-M
	VS88NBR	VS88NBRIM18V	VS88NBRIM14V	VS88NBRIF14V	VS88NBRIM14	VS88NBRIF14
VS88SIT5	VS88SIT5IM18V	VS88SIT5IM14V	VS88SIT5IF14V	VS88SIT5IM14	VS88SIT5IF14	VS88SIT5IM38
VS88NR	VS88NRIM18V	VS88NRIM14V	VS88NRIF14V	VS88NRIM14	VS88NRIF14	VS88NRIM38

VS

Suction Cups with 2.5 Bellows Ø 5 to 88 mm

Dimensions - "Suction Cup + Fitting"



VS 2

VS 5 - 9 Group 1 **VS 12 - 25 Group 1**

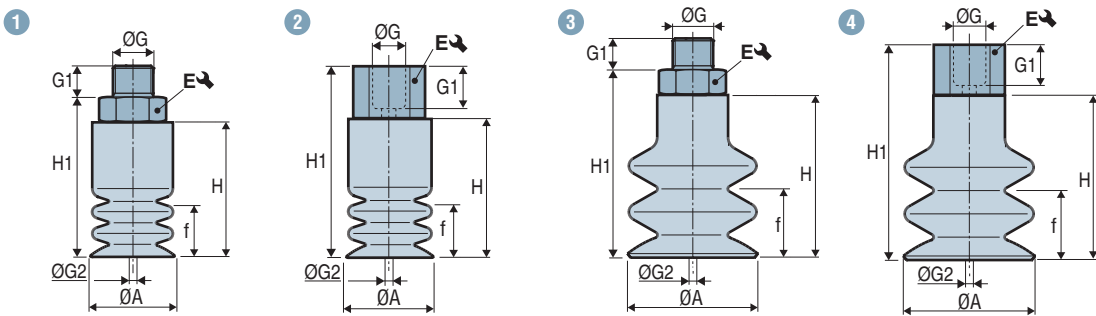

VS 26 - 62 Group 2 **VS 88 Group 3**

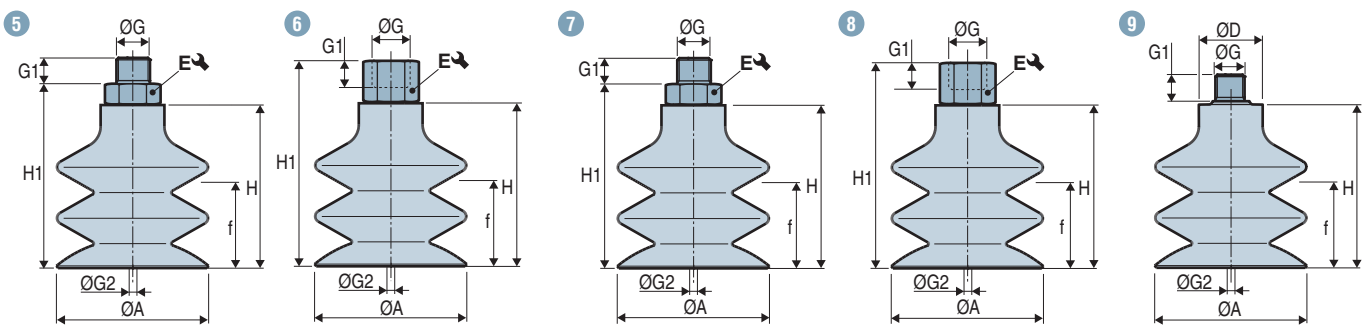

Group 1	Diagram	ØA	ØD	f ⁽¹⁾	H	H1	ØG	G1	ØG2 ⁽²⁾	E ↘	⊃ (g)	
Ø 5 - 25 mm	VS5---IMM3C	1	5	-	3	13.5	15.5	M3-M	3	1.4	5	0.7
	VS6---IMM3C	1	6	-	3	13.2	15.2	M3-M	3	1.4	5	0.7
	VS7---IMM5C	1	7	-	3	13.5	18.5	M5-M	4.5	2.5	7	3.5
	VS7---IMM6C	1	7	-	3	13.5	18.5	M6-M	5	3.5	7	3.1
	VS7---IM18C	1	7	-	3	13.5	19.5	G1/8"-M	7.5	3.5	14	4.5
	VS7---IF18C	2	7	-	3	13.5	25.5	G1/8"-F	8	3.5	14	4.4
	VS9---IMM5C	1	9	-	3	15	20	M5-M	4.5	2.5	7	3.7
	VS9---IMM6C	1	9	-	3	15	20	M6-M	5	3.5	7	3.3
	VS9---IM18C	1	9	-	3	15	21	G1/8"-M	7.5	3.5	14	4.8
	VS9---IF18C	2	9	-	3	15	27	G1/8"-F	8	3.5	14	4.6
	VS12---IMM5C	3	12	-	7	21	26	M5-M	4.5	2.5	7	3.2
	VS12---IMM6C	3	12	-	7	21	26	M6-M	5	3.5	7	3.8
	VS12---IM18C	3	12	-	7	21	27	G1/8"-M	7.5	3.5	14	5.2
	VS12---IF18C	4	12	-	7	21	33	G1/8"-F	8	3.5	14	5.1
	VS14---IMM5C	3	14	-	10	23	28	M5-M	4.5	2.5	7	4.6
	VS14---IMM6C	3	14	-	10	23	28	M6-M	5	3.5	7	4.2
	VS14---IM18C	3	14	-	10	23	29	G1/8"-M	7.5	3.5	14	5.6
	VS14---IF18C	4	14	-	10	23	35	G1/8"-F	8	3.5	14	5.5
	VS18---IMM5C	3	17.5	-	10	23	28	M5-M	4.5	2.5	7	5.1
	VS18---IMM6C	3	17.5	-	10	23	28	M6-M	5	3.5	7	4.7
	VS18---IM18C	3	17.5	-	10	23	29	G1/8"-M	7.5	3.5	14	6.1
	VS18---IF18C	4	17.5	-	10	23	35	G1/8"-F	8	3.5	14	6
	VS20---IMM5C	3	20	-	10	23	28	M5-M	4.5	2.5	7	5.5
	VS20---IMM6C	3	20	-	10	23	28	M6-M	5	3.5	7	5.1
	VS20---IM18C	3	20	-	10	23	29	G1/8"-M	7.5	3.5	14	6.5
VS20---IF18C	4	20	-	10	23	35	G1/8"-F	8	3.5	14	6.4	
VS25---IMM5C	3	25	-	20	34	39	M5-M	4.5	2.5	7	7.4	
VS25---IMM6C	3	25	-	20	34	39	M6-M	5	3.5	7	7	
VS25---IM18C	3	25	-	20	34	40	G1/8"-M	7.5	3.5	14	8.4	
VS25---IF18C	4	25	-	20	34	46	G1/8"-F	8	3.5	14	8.3	

Note: All dimensions are in mm.

(1) f = Deflection of the suction cup. (2) Ø G2 = Ø internal orifice of the fitting.

VS

Suction Cups with 2.5 Bellows Ø 5 to 88 mm

Dimensions - "Suction Cup + Fitting"



Group 2	Diagram	ØA	ØD	f ⁽¹⁾	H	H1	ØG	G1	ØG2 ⁽²⁾	E ↻	⚖ (g)	
Ø 26 - 62 mm	VS26---IM18V	5	25	-	11	31	35.5	G1/8"-M	6	3.5	13	20.2
	VS26---IF18V	6	25	-	11	31	44	G1/8"-F	7.5	3.5	13	23.5
	VS26---IM14	5	25	-	11	31	35	G1/4"-M	11	4.4	17	14.1
	VS26---IM14C	5	25	-	11	31	39	G1/4"-M	10	7	17	15
	VS26---IM14V	5	25	-	11	31	36	G1/4"-M	8	3.5	17	29.5
	VS26---IF14	6	25	-	11	31	46	G1/4"-F	10	4.4	17	14.7
	VS26---IF14C	6	25	-	11	31	46	G1/4"-F	12	6.9	17	14.3
	VS26---IF14V	6	25	-	11	31	47	G1/4"-F	11	3.5	17	34.1
	VS32---IM18V	5	32	-	14.5	37.5	42	G1/8"-M	6	3.5	13	22.9
	VS32---IF18V	6	32	-	14.5	37.5	50.5	G1/8"-F	7.5	3.5	13	26.2
	VS32---IM14	5	32	-	14.5	37.5	41.5	G1/4"-M	11	4.4	17	16.8
	VS32---IM14C	5	32	-	14.5	37.5	45.5	G1/4"-M	10	7	17	17.7
	VS32---IM14V	5	32	-	14.5	37.5	42.5	G1/4"-M	8	3.5	17	32.2
	VS32---IF14	6	32	-	14.5	37.5	52.5	G1/4"-F	10	4.4	17	17.4
	VS32---IF14C	6	32	-	14.5	37.5	52.5	G1/4"-F	12	6.9	17	17
	VS32---IF14V	6	32	-	14.5	37.5	53.5	G1/4"-F	11	3.5	17	36.8
	VS42---IM18V	5	42	-	22	46	50.5	G1/8"-M	6	3.5	13	32.1
	VS42---IF18V	6	42	-	22	46	59	G1/8"-F	7.5	3.5	13	35.4
	VS42---IM14	5	42	-	22	46	50	G1/4"-M	11	4.4	17	26
	VS42---IM14C	5	42	-	22	46	54	G1/4"-M	10	7	17	26.2
	VS42---IM14V	5	42	-	22	46	51	G1/4"-M	8	3.5	17	41.4
	VS42---IF14	6	42	-	22	46	61	G1/4"-F	10	4.4	17	26.6
	VS42---IF14C	6	42	-	22	46	61	G1/4"-F	12	6.9	17	26.2
	VS42---IF14V	6	42	-	22	46	62	G1/4"-F	11	3.5	17	46
	VS52---IM18V	5	52	-	27	49	53.5	G1/8"-M	6	3.5	13	38.1
	VS52---IF18V	6	52	-	27	49	62	G1/8"-F	7.5	3.5	13	41.4
	VS52---IM14	5	52	-	27	49	53	G1/4"-M	11	4.4	17	32
	VS52---IM14C	5	52	-	27	49	57	G1/4"-M	10	7	17	32.9
	VS52---IM14V	5	52	-	27	49	54	G1/4"-M	8	3.5	17	47.4
	VS52---IF14	6	52	-	27	49	64	G1/4"-F	10	4.4	17	32.6
	VS52---IF14C	6	52	-	27	49	64	G1/4"-F	12	6.9	17	32.2
	VS52---IF14V	6	52	-	27	49	65	G1/4"-F	11	3.5	17	52
VS62---IM18V	5	62	-	31	55	59.5	G1/8"-M	6	3.5	13	51	
VS62---IF18V	6	62	-	31	55	68	G1/8"-F	7.5	3.5	13	54.3	
VS62---IM14	5	62	-	31	55	59	G1/4"-M	11	4.4	17	44.9	
VS62---IM14C	5	62	-	31	55	63	G1/4"-M	10	7	17	45.8	
VS62---IM14V	5	62	-	31	55	60	G1/4"-M	8	3.5	17	60.3	
VS62---IF14	6	62	-	31	55	70	G1/4"-F	10	4.4	17	45.5	
VS62---IF14C	6	62	-	31	55	70	G1/4"-F	12	6.9	17	45.1	
VS62---IF14V	6	62	-	31	55	71	G1/4"-F	11	3.5	17	65	

Group 3

Ø 88 mm	VS88---IM18V	9	88	25	48.5	87.5	-	G1/8"-M	8	6	-	142.8
	VS88---IM14	7	88	-	48.5	87.5	93.5	G1/4"-M	11	8	21	153.4
	VS88---IM14V	7	88	-	48.5	87.5	92.5	G1/4"-M	8	6	17	163
	VS88---IF14	8	88	-	48.5	87.5	102.5	G1/4"-F	10	8	21	130.8
	VS88---IF14V	8	88	-	48.5	87.5	106.5	G1/4"-F	9	6	17	134.7
	VS88---IM38	7	88	-	48.5	87.5	93.5	G3/8"-M	11	8	21	133

Note: All dimensions are in mm.

(1) f = Deflection of the suction cup.

(2) Ø G2 = Ø internal orifice of the fitting.

VS

Suction Cups with 2.5 Bellows Ø 5 to 88 mm

Assembly Diagrams



2 VS

VS 5 - 25 Group 1

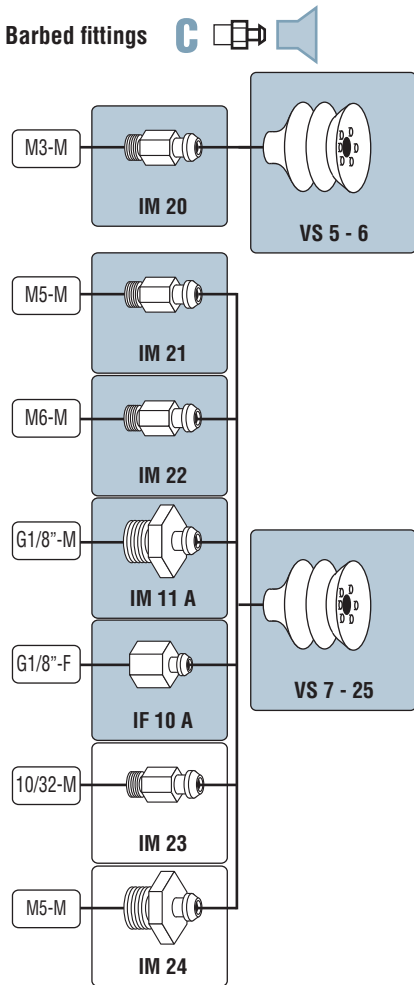

VS 26 - 62 Group 2

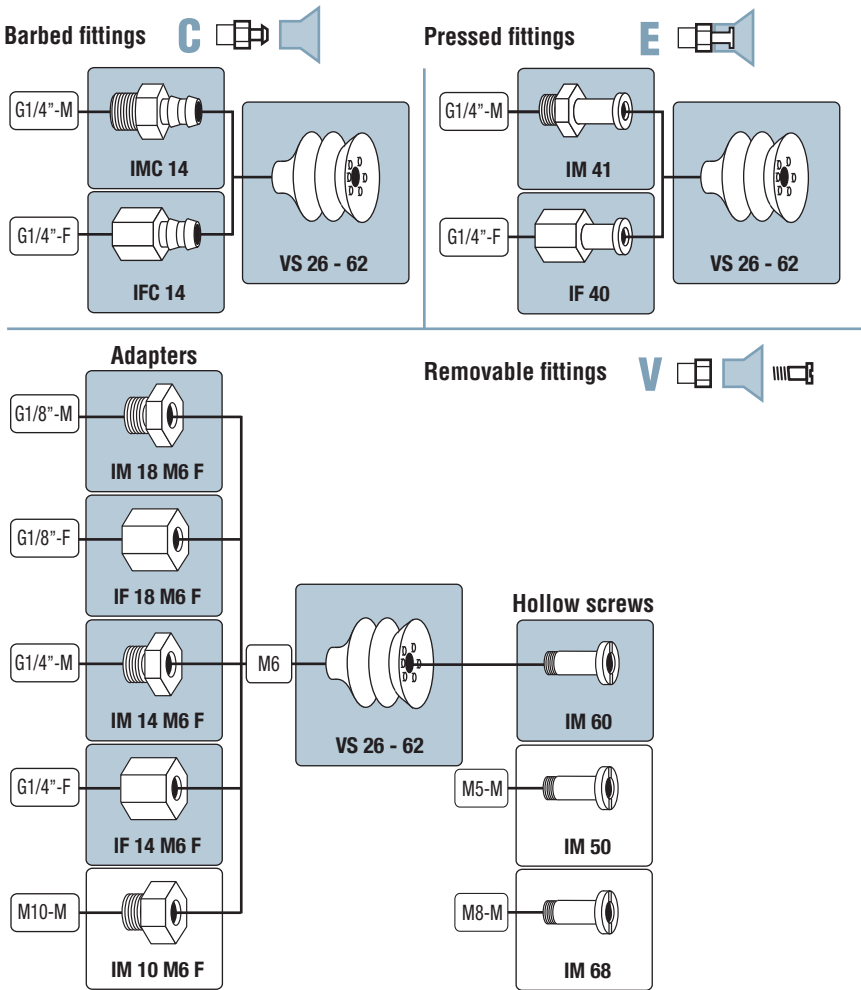

VS 88 Group 3

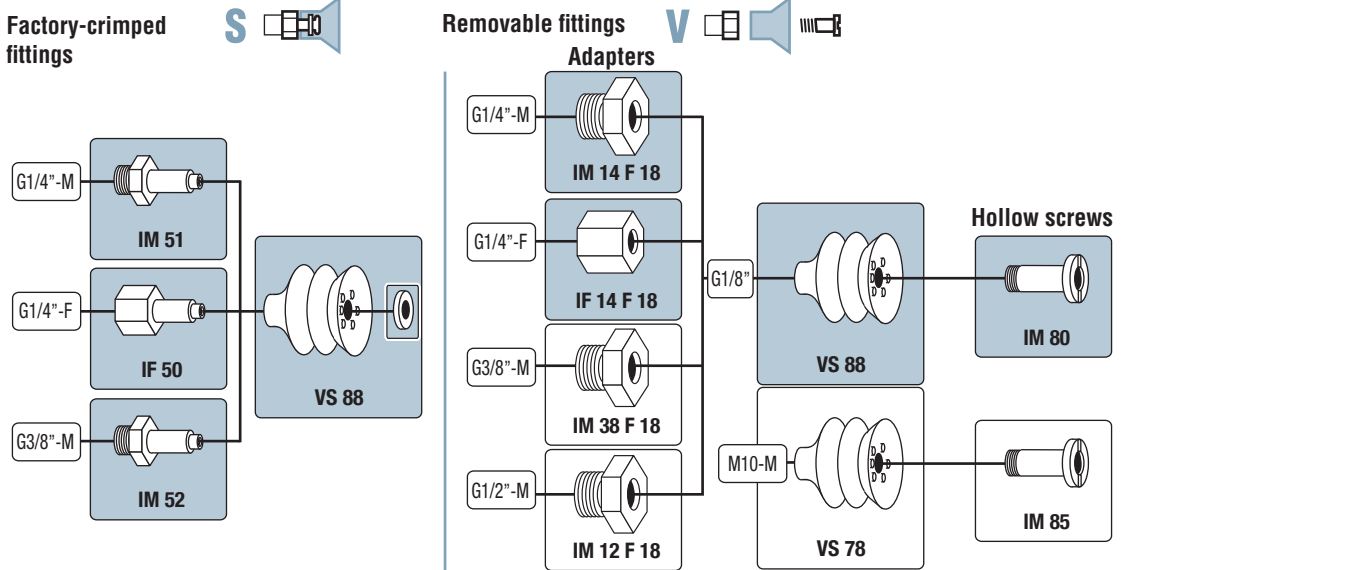

Configurations (suction cup + fitting) refer to page 2/48
 Non-standard configurations must be ordered in separate part numbers.

Fittings and suction cups dimension: see page 2/52.



Suction Cups

VS 5 - 25

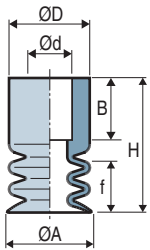

VS 26 - 62

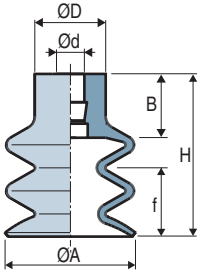

VS 88

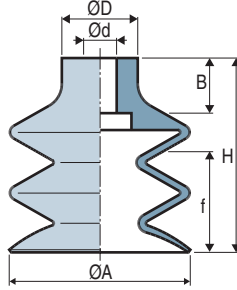

(1) f = Deflection of the suction cup.

Hollow Screws

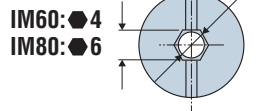
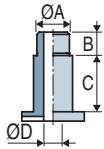

	ØA	B	C	ØD	Material	(g)
IM 50	M5-M	5	11	2.8	Brass	7.4
IM 60 ⁽²⁾⁽³⁾	M6-M	7	11	3.5	Nickel-plated brass	7.3
IM 68	M8-M	8	11	5.2	Nickel-plated brass	6.5
IM 80	G1/8"-M	8	18	6	Nickel-plated brass	23.8
IM 85	M10x150-M	8	18	6	Nickel-plated brass	23.5

Factory-Crimped Fittings

Male - IM

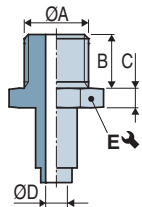

Female - IF

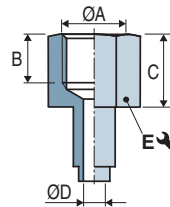

	ØA	B	C	ØD	E ↷	Material	(g)
IM 51	G1/4"-M	11	6	8	21	Aluminum	11.8
IF 50	G1/4"-F	10	15	8	21	Aluminum	15.7
IM 52	G3/8"-M	11	6	8	21	Aluminum	14

Pressed Fittings

Male - IM

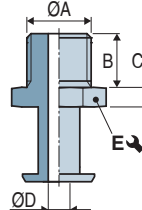

Female - IF

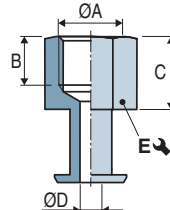

	ØA	B	C	ØD	E ↷	Material	(g)
IM 41	G1/4"-M	11	4	4.4	17	Aluminum	7.8
IF 40	G1/4"-F	10	15	4.4	17	Aluminum	8.4

	ØA	H	Ød	ØD	f ⁽¹⁾	B	(g)
VS 5	5	13.5	4	7	3	8	0.3
VS 6	6	13.2	4	7	3	7	0.31
VS 7	7	13.5	4.7	9	3	6	0.42
VS 9	9	15	4.4	9	3	7	0.64
VS 12	12	21	4	10	7	9	1.1
VS 14	14	23	4	10	10	9	1.5
VS 18	17.5	23	4	10	10	9	2
VS 20	20	23	4	10	10	9	2.4
VS 25	25	34	4	10	20	9	4.3
VS 26	25	31	8	16	11	13	6.3
VS 32	32	37.5	8	18	14.5	13	9
VS 42	42	46	8	18	22	13	18.2
VS 52	52	49	8	18	27	13	24.2
VS 62	62	55	8	21	31	13	37.1
VS 88	88	87.5	12	25	48.5	20	119

Barbed Fittings

Male - IM

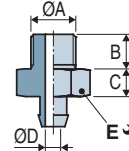

Female - IF

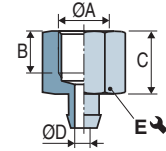

	ØA	B	C	ØD	E ↷	Material	(g)
IM 11 A	G1/8"-M	7.5	6	3.5	14	Aluminum	4.1
IMC 14	G1/4"-M	10	8	7	17	Aluminum	8.7
IM 20	M3-M	3	2	1.4	5	Aluminum	0.4
IM 21 ⁽²⁾	M5-M	4.5	5	2.5	7	Nickel-plated brass	3.1
IM 22 ⁽²⁾	M6-M	5	5	3.5	7	Nickel-plated brass	2.7
IM 23	10/32-M	4.5	5	2.5	7	Brass	3
IM 24	M5-M	4.5	2.5	2.5	10	Nickel-plated brass	3.2
IF 10 A	G1/8"-F	8	12	3.5	14	Aluminum	4
IFC 14	G1/4"-F	12	15	6.9	17	Aluminum	8

Adapters for Hollow Screws

Male - IM

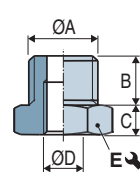

Female - IF

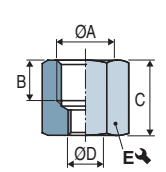

	ØA	B	C	ØD	E ↷	Material	(g)
IM 10 M6F	M10-M	7	3.5	M6-F	13	Brass	5.9
IM 12 F18	G1/2"-M	14	6	G1/8"-F	22	Nickel-plated brass	46.8
IM 14 M6F	G1/4"-M	8	5	M6-F	17	Nickel-plated brass	15.9
IM 14 F18	G1/4"-M	8	5	G1/8"-F	17	Nickel-plated brass	10.6
IM 18 M6F	G1/8"-M	6	4.5	M6-F	13	Nickel-plated brass	6.6
IM 38 F18	G3/8"-M	9	5	G1/8"-F	19	Nickel-plated brass	18.8
IF 14 M6F	G1/4"-F	11	16	M6-F	17	Nickel-plated brass	20.5
IF 18 M6F	G1/8"-F	7.5	13	M6-F	13	Nickel-plated brass	9.9
IF 14 F18	G1/4"-F	9	19	G1/8"-F	17	Nickel-plated brass	20.2

The values represent the average characteristics of our products.

(2) Flow restrictor version available: orifice calibrated to reduce leaks when used with a multi-cup gripper (see page 4/10)

(3) Available in stainless steel

Note: All dimensions are in mm.



Industry-specific applications

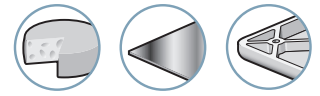

Types of use



The VSG series 2.5 bellows suction cups benefit from very flexible lips allowing the gripping of small concave or convex products. They are ideal for the gripping of sensitive products which require a soft lip.





Materials

NBR Nitrile
SI Silicone
STN SITON®

2

VSG

Suction Cup Properties

	Ø (mm)	 (cm ³)	 (N) ⁽¹⁾	 (mm)	NBR	SI	STN
VSG 5	5	0.03	0.4	3.5	VSG5NBR	VSG5SI	VSG5STN
VSG 7	7	0.04	1.0	4	VSG7NBR	VSG7SI	VSG7STN

(1) Actual force of the suction cup in use with 65% vacuum and including a safety factor of 2 for horizontal handling.

Choice of Fittings

 (Ø)	M5-M	M5-F	G1/8"-M	G1/8"-F
5 - 7	■	■	■	■

■ Standard available configurations (suction cup + fitting) Fitting: M = male
 See part n° table below F = female

Type of Assembly

C  **Version C**
 Barbed fitting

References - "Suction Cup + Fitting"

		C 			
	THREAD	M5-M	M5-F	G1/8"-M	G1/8"-F
Ø 5 - 7 mm	VSG5NBR	VSG5NBRIMM5C	VSG5NBRIFM5C	VSG5NBRIM18C	VSG5NBRIF18C
	VSG5SI	VSG5SIIMM5C	VSG5SIIFM5C	VSG5SIIM18C	VSG5SIIF18C
	VSG5STN	VSG5STNIMM5C	VSG5STNIFM5C	VSG5STNIM18C	VSG5STNIF18C
	VSG7NBR	VSG7NBRIMM5C	VSG7NBRIFM5C	VSG7NBRIM18C	VSG7NBRIF18C
	VSG7SI	VSG7SIIMM5C	VSG7SIIFM5C	VSG7SIIM18C	VSG7SIIF18C
	VSG7STN	VSG7STNIMM5C	VSG7STNIFM5C	VSG7STNIM18C	VSG7STNIF18C

Accessories

To optimize use of your suction cups, Coval offers a comprehensive range of accessories (sensors, spring systems, extensions, feeder systems, etc.) see chapters 4 and 14.



Please specify the part n°. e.g. VSG5NBR
 See part n° table above



Suction Cups + Fittings

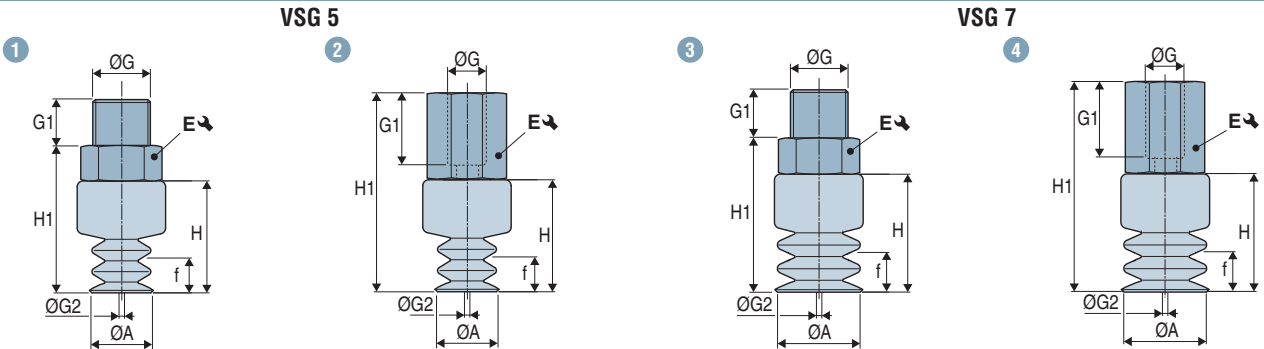
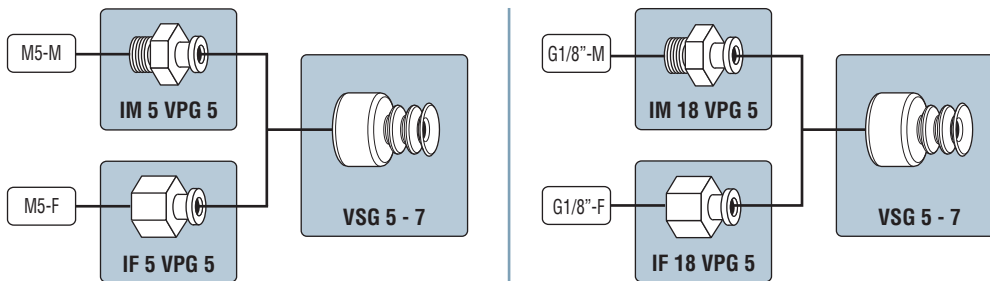

	Diagram	ØA	f ⁽¹⁾	H	H1	ØG	G1	ØG2 ⁽²⁾	E ↻	⚖ (g)
VSG5-IMM5C	1	5	3	9.5	13	M5-M	4.5	2.2	7	2.6
VSG5-IFM5C	2	5	3	9.5	18.5	M5-F	6	2.2	8	3.1
VSG5-IM18C	1	5	3	9.5	14.5	G1/8"-M	8	2.2	14	5.8
VSG5-IF18C	2	5	3	9.5	24.5	G1/8"-F	9	2.2	14	7
VSG7-IMM5C	3	7	3	10	13.5	M5-M	4.5	2.2	7	0.9
VSG7-IFM5C	4	7	3	10	19	M5-F	6	2.2	8	1.4
VSG7-IM18C	3	7	3	10	15	G1/8"-M	8	2.2	14	4.1
VSG7-IF18C	4	7	3	10	25	G1/8"-F	9	2.2	14	5.3

(1) f = Deflection of the suction cup. (2) Ø G2 = Ø internal orifice of the fitting.

Assembly Diagrams



Suction Cups

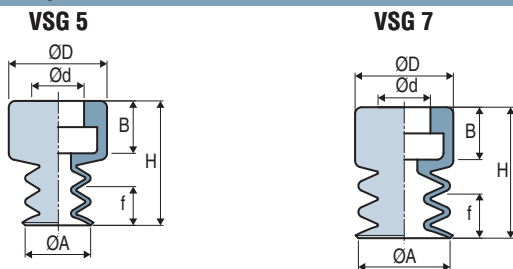

	ØA	H	Ød	ØD	f ⁽¹⁾	B	⚖ (g)
VSG 5	5	9.5	4	7.5	3	4	1.9
VSG 7	7	10	4	7.5	3	4	0.24

(1) f = Deflection of the suction cup

Barbed Fittings

Male - IM

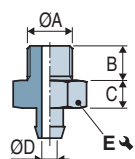

Female - IF

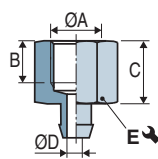

	ØA	B	C	ØD	E ↻	Material	⚖ (g)
IM 5 VPG 5	M5-M	4.5	3.5	2.2	7	Aluminum	0.7
IF 5 VPG 5	M5-F	6	9	2.2	8	Aluminum	1.2
IM 18 VPG 5	G1/8"-M	8	5	2.2	14	Aluminum	3.9
IF 18 VPG 5	G1/8"-F	9	15	2.2	14	Aluminum	5.1

The values represent the average characteristics of our products.

Note: All dimensions are in mm.

VSD

Long Stroke Suction Cups



Long stroke suction cups (4.5 and 5.5 bellows) are specially recommended for handling spherical or cylindrical objects or which require compensation for varying heights.

Industry-specific applications

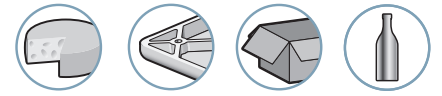

Types of use



2

VSD

Materials

- NBR** Nitrile
- SIT3** 30 Shore A translucent
- SIT5** 50 Shore A translucent silicone

Suction Cup Properties

	Ø (mm)	Volume (cm ³)	Force (N) ⁽¹⁾	R _{min} (mm)	NBR	SIT3	SIT5
VSD 18	17.5	2.5	4.5	20	-	-	VSD18SIT5
VSD 32	32	21.7	10.5	35	VSD32NBR	VSD32SIT3	-
VSD 62	62	111	50	75	VSD62NBR	-	-

(1) Actual force of the suction cup in use with 65% vacuum and including a safety factor of 2 for horizontal handling.

Choice of Fittings

	Group	M5-M	M6-M	M8-M	M10-M	G1/8"-F	G1/8"-M	10/32-M	G1/4"-F	G1/4"-M
VSD 18	1	■	■	-	-	■	■	□	-	-
VSD 32-62	2	□	□	□	□	■	■	-	■	■

■ Standard available configurations (suction cup + fitting) □ Additional mounting configurations
See part n° below see page 2/57

Fitting: M = male F = female

Types of Assembly

COVAL suction cups can be assembled in a wide variety of configurations.



Version C: Factory-crimped fitting



Version E: Pressed fitting



Version V: Removable fitting:
(adapter and hollow screw)

References - "Suction Cup + Fitting"

Group 1					
Ø 18	THREAD	M5-M	M6-M	G1/8"-M	G1/8"-F
VSD18SIT5		VSD18SIT5IMM5C	VSD18SIT5IMM6C	VSD18SIT5IM18C	VSD18SIT5IF18C

Group 2																	
Ø 32-62	THREAD	G1/4"-M	G1/4"-F	G1/4"-M	G1/4"-F	G1/8"-M	G1/8"-F	G1/4"-M	G1/4"-F	G1/8"-M	G1/8"-F	G1/4"-M	G1/4"-F	G1/8"-M	G1/8"-F	G1/4"-M	G1/4"-F
VSD32NBR		VSD32NBRIM14C	VSD32NBRIF14C	VSD32NBRIM14	VSD32NBRIF14	VSD32NBRIM18V	VSD32NBRIF18V	VSD32NBRIM14V	VSD32NBRIF14V	VSD32NBRIM18V	VSD32NBRIF18V	VSD32NBRIM14V	VSD32NBRIF14V	VSD32NBRIM18V	VSD32NBRIF18V	VSD32NBRIM14V	VSD32NBRIF14V
VSD32SIT3		VSD32SIT3IM14C	VSD32SIT3IF14C	VSD32SIT3IM14	VSD32SIT3IF14	VSD32SIT3IM18V	VSD32SIT3IF18V	VSD32SIT3IM14V	VSD32SIT3IF14V	VSD32SIT3IM18V	VSD32SIT3IF18V	VSD32SIT3IM14V	VSD32SIT3IF14V	VSD32SIT3IM18V	VSD32SIT3IF18V	VSD32SIT3IM14V	VSD32SIT3IF14V
VSD62NBR		VSD62NBRIM14C	VSD62NBRIF14C	VSD62NBRIM14	VSD62NBRIF14	VSD62NBRIM18V	VSD62NBRIF18V	VSD62NBRIM14V	VSD62NBRIF14V	VSD62NBRIM18V	VSD62NBRIF18V	VSD62NBRIM14V	VSD62NBRIF14V	VSD62NBRIM18V	VSD62NBRIF18V	VSD62NBRIM14V	VSD62NBRIF14V



Please specify the part n°. e.g. **VSD18SIT5IMM5C**
See part n° table above

Accessories

To optimize use of your suction cups, Coval offers a comprehensive range of accessories (sensors, spring systems, extensions, feeder systems, etc.) see chapters 4 and 14.



VSD 18 Group 1

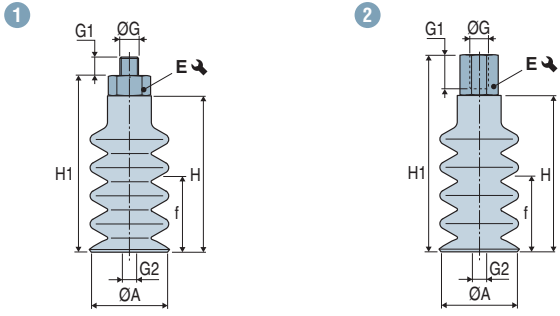

VSD 32 Group 2

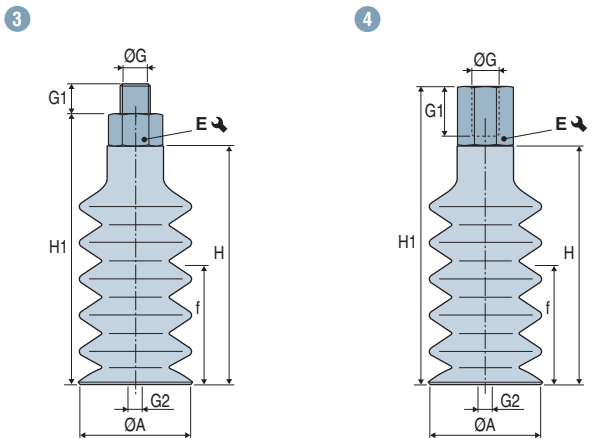

VSD 62 Group 2

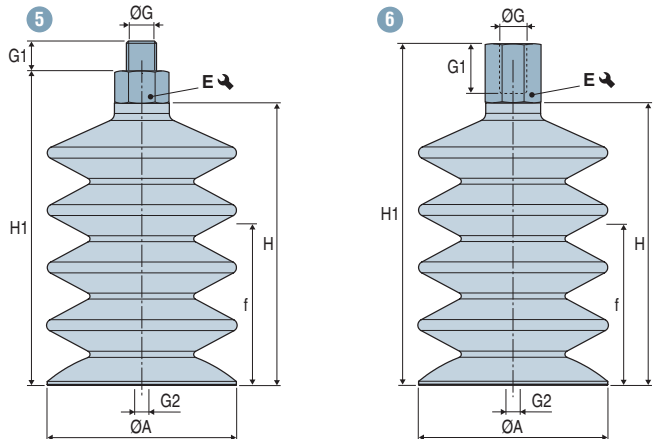

Group 1		Diagram	ØA	f ⁽¹⁾	H	H1	ØG	G1	ØG2 ⁽²⁾	E ↘	⚖ (g)
Ø 18 mm	VSD18-IMM5C	1	17.5	18	36	41	M5-M	4.5	2.5	7	6.2
	VSD18-IMM6C	1	17.5	18	36	41	M6-M	5	3.5	7	5.8
	VSD18-IM18C	1	17.5	18	36	42	G1/8"-M	7.5	3.5	14	7.2
	VSD18-IF18C	2	17.5	18	36	48	G1/8"-F	8	3.5	14	7.1

Group 2		Diagram	ØA	f ⁽¹⁾	H	H1	G	G1	ØG2 ⁽²⁾	E ↘	⚖ (g)
Ø 32 - 62 mm	VSD32-IM18V	3	32	34	65	69.5	G1/8"-M	6	3.5	13	29.2
	VSD32-IF18V	4	32	34	65	78	G1/8"-F	7.5	3.5	13	32.5
	VSD32-IM14	3	32	34	65	69	G1/4"-M	11	4.4	17	22.9
	VSD32-IM14C	3	32	34	65	73	G1/4"-M	10	7	17	23.8
	VSD32-IM14V	3	32	34	65	70	G1/4"-M	8	3.5	17	38.5
	VSD32-IF14	4	32	34	65	80	G1/4"-F	10	4.4	17	23.7
	VSD32-IF14C	4	32	34	65	80	G1/4"-F	12	6.9	17	23.1
	VSD32-IF14V	4	32	34	65	81	G1/4"-F	11	3.5	17	43.5
	VSD62-IM18V	5	62	55	92.5	97	G1/8"-M	6	3.5	13	76.7
	VSD62-IF18V	6	62	55	92.5	105.5	G1/8"-F	7.5	3.5	13	80
	VSD62-IM14	5	62	55	92.5	96.5	G1/4"-M	11	4.4	17	70.4
	VSD62-IM14C	5	62	55	92.5	100.5	G1/4"-M	10	7	17	71.3
	VSD62-IM14V	5	62	55	92.5	97.5	G1/4"-M	8	3.5	17	86
	VSD62-IF14	6	62	55	92.5	107.5	G1/4"-F	10	4.4	17	71.2
VSD62-IF14C	6	62	55	92.5	107.5	G1/4"-F	12	6.9	17	70.6	
VSD62-IF14V	6	62	55	92.5	108.5	G1/4"-F	11	3.5	17	90.6	

(1) f = Deflection of the suction cup. (2) Ø G2 = Ø internal orifice of the fitting.

Note: All dimensions are in mm.

Assembly diagrams
See page 2/57.

VSD

Long Stroke Suction Cups

Assembly Diagrams



2
VSD

VSD 18 Group 1

Barbed fittings **C**

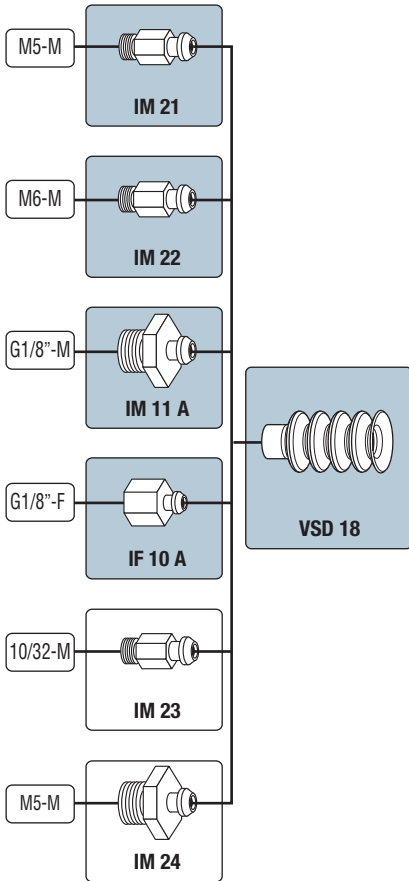

VSD 32-62 Group 2

Barbed fittings **C**

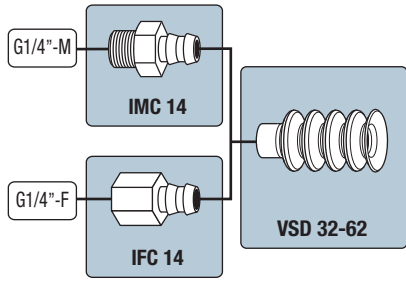

Pressed fittings **E**

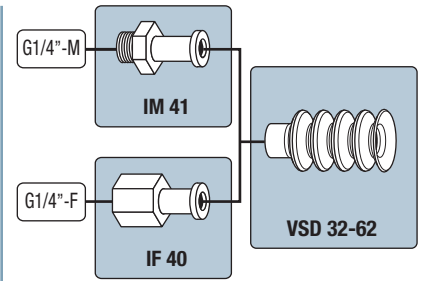

Removable fittings **V**

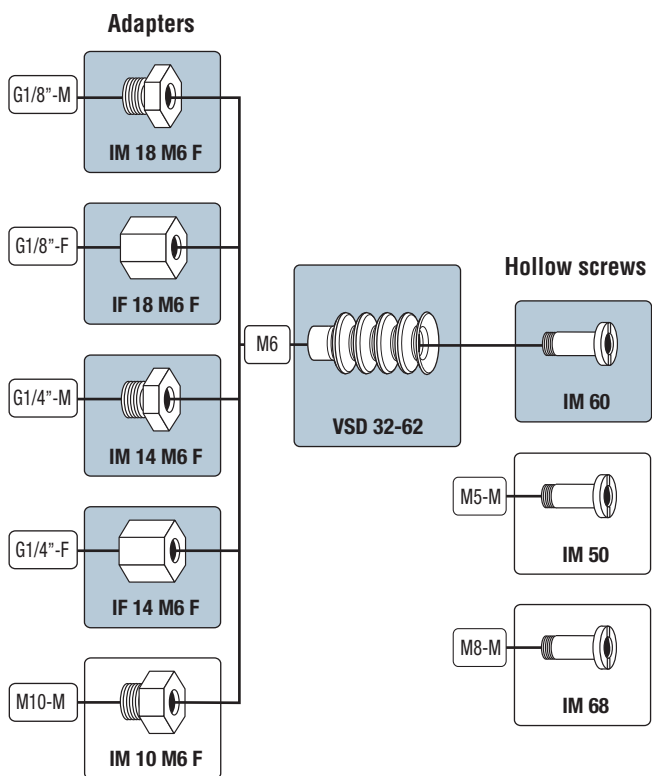

- Configurations (suction cup + fitting) refer to page 2/55
- Non-standard configurations must be ordered in separate part numbers.

VSD

Long Stroke Suction Cups

Dimensions



Suction Cups

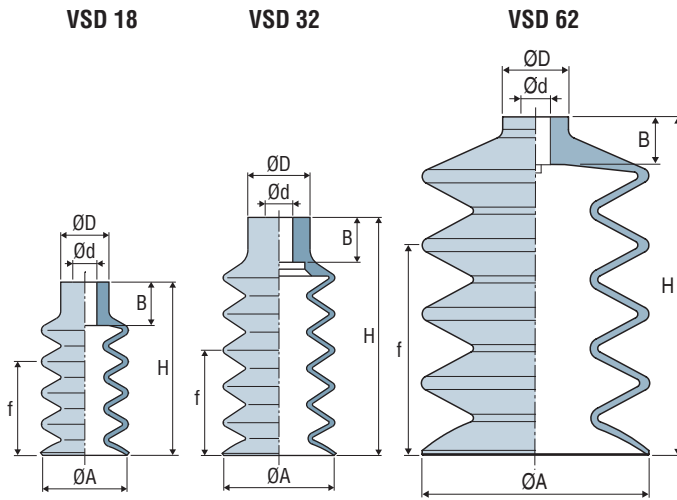

	ØA	f ⁽¹⁾	H	Ød	ØD	B	⊖ (g)
VSD 18	17.5	18	36	4	10	9	3.1
VSD 32	32	34	65	8	18	13	15.1
VSD 62	62	55	92.5	8	18	13	62.6

(1) f = Deflection of the suction cup.

2
VSD

Barbed Fittings



	ØA	B	C	ØD	E	Material	⊖ (g)
IM 11 A	G1/8"-M	7.5	6	3.5	14	Aluminum	4.1
IMC 14	G1/4"-M	10	8	7	17	Aluminum	8.7
IM 21⁽²⁾	M5-M	4.5	5	2.5	7	Nickel-plated brass	3.1
IM 22⁽²⁾	M6-M	5	5	3.5	7	Nickel-plated brass	2.7
IM 23	10/32-M	4.5	5	2.5	7	Brass	3.0
IM 24	M5-M	4.5	2.5	2.5	10	Nickel-plated brass	3.2
IF 10 A	G1/8"-F	8	12	3.5	14	Aluminum	4.0
IFC 14	G1/4"-F	12	15	6.9	17	Aluminum	8.0

Hollow Screws



	ØA	B	C	ØD	Material	⊖ (g)
IM 50	M5-M	5	11	2.8	Brass	7.4
IM 60^{(2) (3)}	M6-M	7	11	3.5	Nickel-plated brass	7.5
IM 68	M8-M	8	11	5.2	Nickel-plated brass	6.4

Pressed Fittings

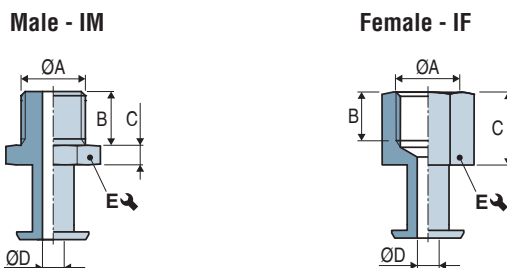

	ØA	B	C	ØD	E	Material	⊖ (g)
IM 41	G1/4"-M	11	4	4.4	17	Aluminum	7.8
IF 40	G1/4"-F	10	15	4.4	17	Aluminum	8.6

Adapters for Hollow Screws



	ØA	B	C	ØD	E	Material	⊖ (g)
IM 10 M6F	M10-M	7	3.5	M6-F	13	Brass	5.9
IM 14 M6F	G1/4"-M	8	5	M6-F	17	Nickel-plated brass	15.9
IM 18 M6F	G1/8"-M	6	4.5	M6-F	13	Nickel-plated brass	6.6
IF 14 M6F	G1/4"-F	11	16	M6-F	17	Nickel-plated brass	20.5
IF 18 M6F	G1/8"-F	7.5	13	M6-F	13	Nickel-plated brass	9.9

The values represent the average characteristics of our products.

Note: All dimensions are in mm.

(2) Flow restrictor version available: orifice calibrated to reduce leaks when used with a multi-cup gripper (see page 4/10).

(3) Available in stainless steel.

C

High-performance Suction Cups



Industry-specific applications

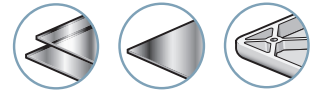

Types of use



2



Characteristics

- Extreme resistance to slipping and acceleration.
- 2 suction cup materials available depending on the model (Nitrile or SITON®).
- Ideal for automated applications.
- Rigid central stopper with integrated cleats allows gripping of thin sheet metal without any deformation.
- Lightweight polyamide fittings allow for better integration on end-of-arm tooling.
- Airtight sealing lips.
- Airtight fittings using:
 - O-rings on G3/8" male cylindrical suction cups and 32 square suction cups
 - Sealing ring on all oblong 3/8" male suction cups.
- Visual wear indicator.
- Double tightening: external with 22 mm wrench or internal with 6 or 8 mm hex key.

Materials

Suction cups

- **NBR nitrile 55 Shore A**
 - High resistance to oils and supports peak temperatures up to 100°C (212°F).
 - Colors: gray for suction cups with polyamide fittings, and blue-green for suction cups with aluminum fittings.
- **STNV6 SITON® 60 Shore A**
 - High resistance to oils, supports peak temperatures up to 160°C (320°F) and features excellent abrasion resistance.
 - Color: green.

Fittings

- **PA**
 - Polyamide filled with fiberglass (PA 6.6 30% FG), ensures weight savings, avoids risk of deterioration of expensive tools, and facilitates suction cup recycling. (fitting M38G/F38G).
- **AL**
 - Aluminum (M38GA/F38GA/C32 Fitting).
- O-ring: NBR Nitrile Blue.

Range

The COVAL **C Series** high performance vacuum cups are available in a complete range of shapes, sizes, materials, and connection types in order to meet all your needs in the most appropriate way.

Models

CFC flat suction cup



CBC 1.5 bellows suction cup



COFC flat oblong suction cup



COBC oblong suction cup with 1.5 bellows

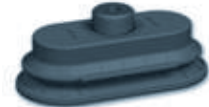

Fittings

M38G male fitting G3/8" (polyamide fitting)



F38G female fitting G3/8" (polyamide fitting)



C32 square coupling 32 mm (polyamide fitting and 32mm square in aluminum)



M38GA male fitting G3/8" (aluminum fitting)



F38GA female fitting G3/8" (aluminum fitting)



Other fittings available on request.



Please specify the part n°. e.g. **CBC85M38G**
Refer to page 2/60

Accessories

To optimize use of your suction cups, Coval offers a comprehensive range of accessories (3/8G extensions, feeders and special couplings for 100% air-tight vacuum networks,) see chapters 4 and 14.

C

High-performance Suction Cups

References - Suction Cups



CFC Flat Suction Cup



		References for nitrile (NBR) suction cups according to the type of fitting					Part No. for SITON® (STNV6) suction cups according to the type of fitting	
		M38G	F38G	M38GA	F38GA	C32	M38G	F38G
CFC35		CFC35M38G	CFC35F38G	CFC35M38GA	CFC35F38GA	CFC35C32	on request	on request
CFC50		CFC50M38G	CFC50F38G	CFC50M38GA	CFC50F38GA	CFC50C32	on request	on request
CFC75		CFC75M38G	CFC75F38G	CFC75M38GA	CFC75F38GA	CFC75C32	CFC75STNV6M38G	CFC75STNV6F38G
CFC100		CFC100M38G	CFC100F38G	CFC100M38GA	CFC100F38GA	CFC100C32	CFC100STNV6M38G	CFC100STNV6F38G
CFC125		CFC125M38G	CFC125F38G	CFC125M38GA	CFC125F38GA	CFC125C32	on request	on request

2





CBC Suction Cup with 1.5 Bellows

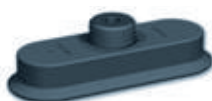

		References for nitrile (NBR) suction cups according to the type of fitting					Part No. for SITON® (STNV6) suction cups according to the type of fitting	
		M38G	F38G	M38GA	F38GA	C32	M38G	F38G
CBC22		CBC22M38G	CBC22F38G	CBC22M38GA	CBC22F38GA	CBC22C32	on request	on request
CBC30		CBC30M38G	CBC30F38G	CBC30M38GA	CBC30F38GA	CBC30C32	on request	on request
CBC45		CBC45M38G	CBC45F38G	CBC45M38GA	CBC45F38GA	CBC45C32	CBC45STNV6M38G	CBC45STNV6F38G
CBC60		CBC60M38G	CBC60F38G	CBC60M38GA	CBC60F38GA	CBC60C32	CBC60STNV6M38G	CBC60STNV6F38G
CBC85		CBC85M38G	CBC85F38G	CBC85M38GA	CBC85F38GA	CBC85C32	CBC85STNV6M38G	CBC85STNV6F38G
CBC115		CBC115M38G	CBC115F38G	CBC115M38GA	CBC115F38GA	CBC115C32	CBC115STNV6M38G	CBC115STNV6F38G
CBC125		CBC125M38G	CBC125F38G	on request	on request	CBC125C32	on request	on request

COFC Flat Oblong Suction Cup



		References for nitrile (NBR) suction cups according to the type of fitting					Part No. for SITON® (STNV6) suction cups according to the type of fitting	
		M38G	F38G	M38GA	F38GA	C32	M38G	F38G
COFC2565		COFC2565M38G	COFC2565F38G	COFC2565M38GA	COFC2565F38GA	COFC2565C32	on request	on request
COFC3080		COFC3080M38G	COFC3080F38G	COFC3080M38GA	COFC3080F38GA	COFC3080C32	on request	on request
COFC4080		COFC4080M38G	COFC4080F38G	COFC4080M38GA	COFC4080F38GA	COFC4080C32	on request	on request
COFC50100		COFC50100M38G	COFC50100F38G	COFC50100M38GA	COFC50100F38GA	COFC50100C32	on request	on request

COBC Oblong Suction Cup with 1.5 Bellows



		References for nitrile (NBR) suction cups according to the type of fitting					Part No. for SITON® (STNV6) suction cups according to the type of fitting	
		M38G	F38G	M38GA	F38GA	C32	M38G	F38G
COBC3065		COBC3065M38G	COBC3065F38G	COBC3065M38GA	COBC3065F38GA	COBC3065C32	COBC3065STNV6M38G	COBC3065STNV6F38G
COBC4080		COBC4080M38G	COBC4080F38G	COBC4080M38GA	COBC4080F38GA	COBC4080C32	COBC4080STNV6M38G	COBC4080STNV6F38G
COBC55110		COBC55110M38G	COBC55110F38G	COBC55110M38GA	COBC55110F38GA	COBC55110C32	COBC55110STNV6M38G	COBC55110STNV6F38G
COBC70140		COBC70140M38G	COBC70140F38G	COBC70140M38GA	COBC70140F38GA	COBC70140C32	on request	on request

C







High-performance Suction Cups

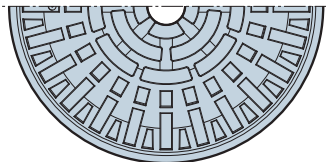
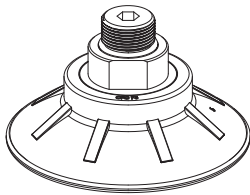

Suction Cup Properties



CFC Flat Suction Cup



		ØA at rest	ØA gripping	 (cm ³)	 (N) ⁽¹⁾	 (N) ⁽¹⁾	 R _{min}	 R _{min}	Ø bore	tightening
CFC 35		37	38.5	2.46	60	56	58	50	6.3	w 22 + hk 6
CFC 50		51	54	8.37	107	110	66	52	6.3	w 22 + hk 6
CFC 75		76	80	25.03	210	225	100	58	6.3	w 22 + hk 6
CFC 100		101	105.7	57.61	350	470	120	90	6.3	w 22 + hk 6
CFC 125		127	132	119.7	600	600	160	115	6.3	w 22 + hk 8

		H1	f ^(*)	G1	G1'	ØD	 (g)				
							F38G	F38GA	M38G	M38GA	C32
CFC 35		25	3	10	12.6	37	14	25.7	18	33.7	36.2
CFC 50		30	5	10	12.6	38	25	34.9	29	42.9	47.2
CFC 75		33	8	10	12.6	41	40	48.9	45	56.9	62.2
CFC 100		38	10	10	12.6	41	67	75.3	72	83.3	89.2
CFC 125		44	14	10	12.6	55	119	146	124	154	141.2

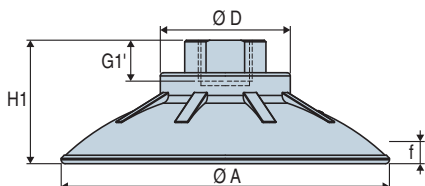

F38G/F38GA Female fitting G3/8"

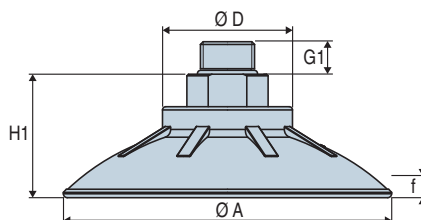



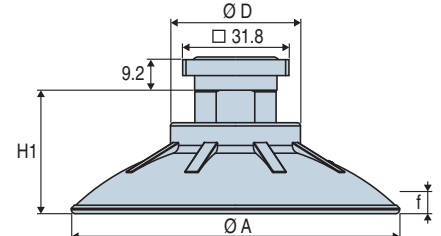



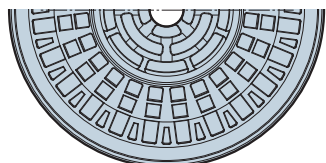
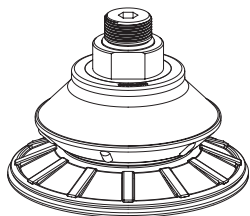

M38G/M38GA Male fitting G3/8"





C32 Square coupling 32

CBC Suction Cup with 1.5 Bellows



		ØA at rest	ØA gripping	 (cm ³)	 (N) ⁽¹⁾⁽²⁾	 (N) ⁽¹⁾⁽³⁾	 (N) ⁽¹⁾	 R _{min}	 R _{min}	Ø bore	tightening
CBC 22		21.5	22	1.6	18	20	17	25	30	6.3	w 22 + hk 6
CBC 30		32	34	5	35	40	33	30	32	6.3	w 22 + hk 6
CBC 45		47	48.7	11.47	39	77	85	36	45	6.3	w 22 + hk 6
CBC 60		62	64.5	25.31	60	135	155	44	62	6.3	w 22 + hk 6
CBC 85		85	88	66.54	125	250	220	65	115	6.3	w 22 + hk 6
CBC 115		115	119	141.47	214	430	430	84	140	6.3	w 22 + hk 8
CBC 125		125	132	200.1	223	475	560	93	155	6.3	w 22 + hk 8

		H1	f ^(*)	G1	G1'	ØD	 (g)				
							F38G	F38GA	M38G	M38GA	C32
CBC 22		32	6	10	12.6	37	10	23	14	31	32.2
CBC 30		31	8	10	12.6	37	14	26.3	19	34.3	36.2
CBC 45		36	11	10	12.6	37	22	31.5	26	39.5	44.2
CBC 60		41	14	10	12.6	39	32	42	37	50	54.2
CBC 85		51	21	10	12.6	41	64	71.2	69	79.2	86.2
CBC 115		53	23	10	12.6	55	103	131.1	107	139.1	125.2
CBC 125		51	24	10	12.6	55	159	/	163	/	181.2

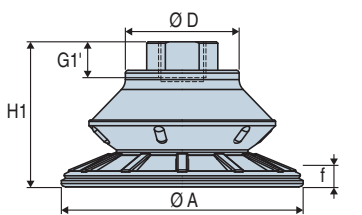

F38G/F38GA Female fitting G3/8"

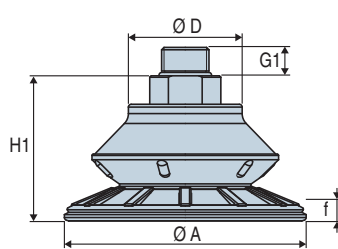

M38G/M38GA Male fitting G3/8"

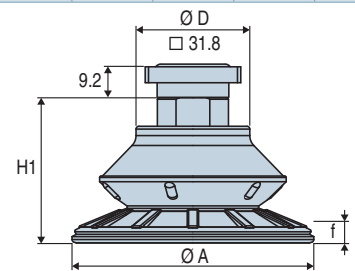

C32 Square coupling 32

(1) Force measured at 65% on dry, smooth, flat sheet metal, without safety factor. The values may change according to the characteristics and the surface of the part.
 (2) Suction force. (3) Pull-off force. (*) f: deflection of the suction cup. Note: All dimensions are in mm.

C

High-performance Suction Cups

Suction Cup Properties



COFC Flat Oblong Suction Cup

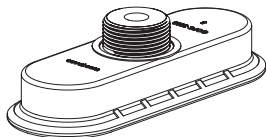

	I x L at rest	I x L gripping	(cm ³)	(N) ⁽¹⁾	(N) ⁽¹⁾	R _{min}	R _{min}	Ø bore	tightening
COFC 2565	25x65	26.8x67	3.78	82	57	25	25	6	hk 6
COFC 3080	30x80	31.5x82	6.08	125	91	40	32	6	hk 6
COFC 4080	40x80	42x82	11.03	145	133	60	40	6	hk 6
COFC 50100	50x100	52.5x102.5	22.25	240	218	70	50	6	hk 6

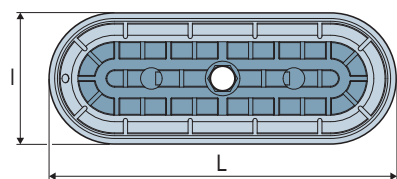

	H1	H	G1	G1'	f ^(*)	(g)				
						F38G	F38GA	M38G	M38GA	C32
COFC 2565	31.5	12.5	8	10	3	24	37.8	17	26.3	35
COFC 3080	32	13	8	10	3	29	42.7	22	31.2	40
COFC 4080	34	15	8	10	4.5	30	45.5	23	34	41
COFC 50100	35	16	8	10	6	43	72.3	36	60.8	54

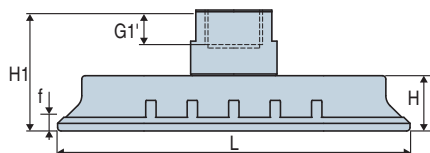

F38G/F38GA Female fitting G3/8"

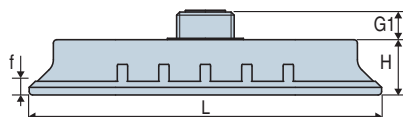

M38G/M38GA Male fitting G3/8"

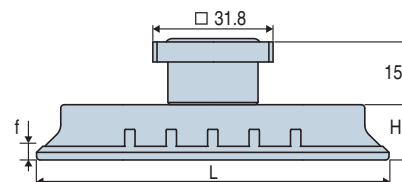

C32 Square coupling 32

COBC Oblong Suction Cup with 1.5 Bellows

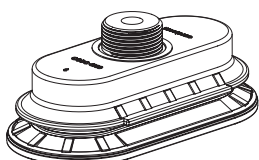

	I x L at rest	I x L gripping	(cm ³)	(N) ⁽¹⁾⁽²⁾	(N) ⁽¹⁾⁽³⁾	(N) ⁽¹⁾	R _{min}	R _{min}	Ø bore	tightening
COBC 3065	31x65	32.3x67	9.98	50	75	87	25	30	6	hk 6
COBC 4080	40x80	41.5x82	19.44	116	130	155	38	37	6	hk 6
COBC 55110	55x110	57x112.5	49.25	170	210	265	58	57	6	hk 6
COBC 70140	70x140	72x143	93.57	270	350	410	72	68	6	hk 6

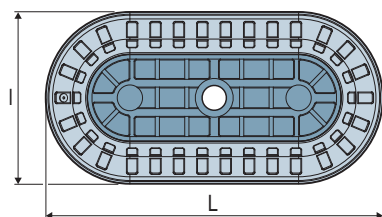

	H1	H	G1	G1'	f ^(*)	(g)				
						F38G	F38GA	M38G	M38GA	C32
COBC 3065	39	20	8	10	7	31	45.5	25	34	43
COBC 4080	41	22	8	10	9.5	37	52.1	31	40.6	49
COBC 55110	48	29	8	10	11.5	68	94.3	62	82.8	80
COBC 70140	49	30	8	10	14.5	103	120.9	97	109.4	115

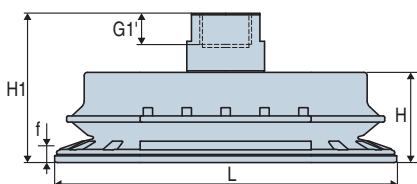

F38G/F38GA Female fitting G3/8"

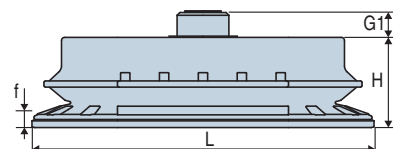

M38G/M38GA Male fitting G3/8"

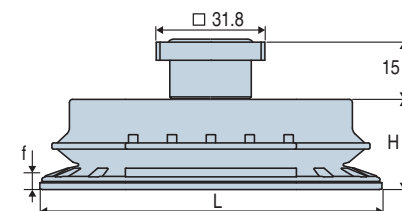

C32 Square coupling 32

The values represent the average characteristics of our products.

(1) Force measured at 65% on dry, smooth, flat sheet metal, without safety factor. The values may change according to the characteristics and the surface of the part.

(2) Suction force. (3) Pull-off force. (*) f = deflection of the suction cup. Note: All dimensions are in mm.





Industry-specific applications

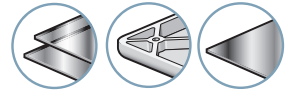

Types of use

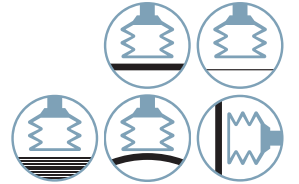

2
CTC

The **CTC Series** high-performance bell-type suction cups have been specifically developed to meet the production requirements of applications in the automotive sector. The bell shape of the **CTC Series** suction cups gives them significant deflection compared to traditional flat suction cups and guarantees better adaptability to the profiles of parts with long lines. The internal stops ensure excellent sliding resistance and allow the gripping of parts without deformation. The characteristics of the **CTC Series** suction cups optimize production in all areas of operation.

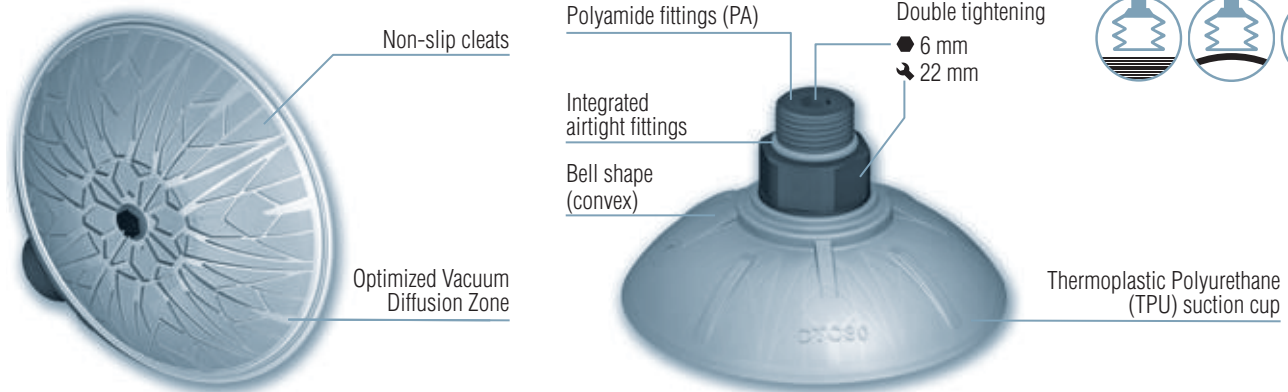

Advantages

- Extreme resistance to slippage and acceleration.
- Excellent adaptation to convex surfaces and angular shapes.
- High deflection compared to standard flat suction cups due to the bell shape.
- Anti-slip cleats ensure precise positioning of oily sheets.
- Particularly suitable for use on high-speed presses, for high speeds and handling of large parts (e.g. body side, roof, doors).
- Deformation-free gripping of thin sheets thanks to central stops.
- 4 diameters for optimal adaptation to each application.
- Excellent resistance to wear and oil thanks to thermoplastic polyurethane (TPU).
- Low weight due to polyamide insert.
- Sealing lips.
- Integrated O-ring seal (male cylindrical G3/8" and square 32 versions).
- Double tightening: 2 flat 22 mm and one hollow hexagonal 6 mm.

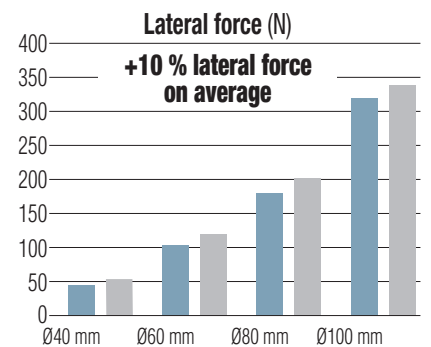
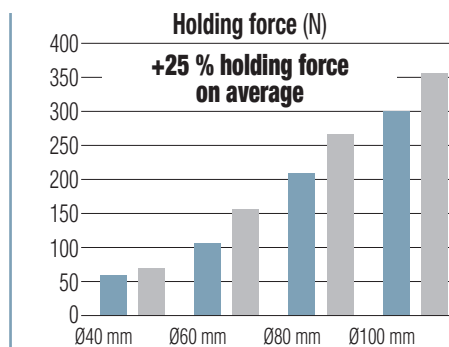
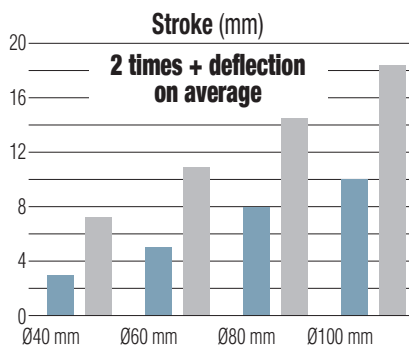

■ Standard suction cups ■ CTC Series

Application Fields

The extreme resistance to slippage and acceleration of the COVAL **CTC Series**, as well as their very low weight, make them particularly well suited for high-speed applications on robots.

The **CTC Series** are dedicated to the handling of sheet metal, glass, and plastics in industries such as stamping, metal forming, mirror manufacturing, and assembly.





Fittings

M38G

Male fitting G3/8"
(polyamide insert)



F38G

Female fitting G3/8"
(polyamide insert)



C32

Square coupling 32 mm
(polyamide fitting and 32mm square in aluminum)



Other fittings available upon request

Characteristics

(1) Force measured at 65% on dry, smooth, and flat sheet metal, without safety coefficient. (2) f = deflection of the suction cup
Note: all dimensions are given in mm.

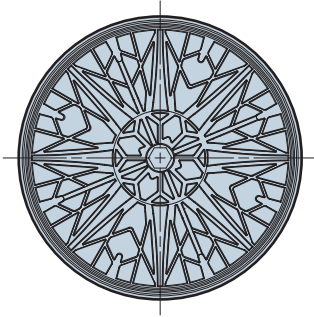

	ØA At rest	ØA gripping	cm ³	(N) ⁽¹⁾	(N) ⁽¹⁾	R _{min}	Ø bore	tightening
CTC 40	43.5	47.6	8.1	70	53	18	6.3	w 22 + hk 6
CTC 60	64.7	71.7	26.1	156	120	24	6.3	w 22 + hk 6
CTC 80	84.1	92.7	72.1	266	202	36	6.3	w 22 + hk 6
CTC 100	106	115.6	103.4	356	338	40	6.3	w 22 + hk 6

	H1	f ⁽²⁾	G1	G1'	ØD	g		
						F38G	M38G	C32
CTC 40	30	7.2	10.5	10.7	32.8	12.9	17.9	35.1
CTC 60	33.9	10.9	10.5	10.7	32.7	18.3	23.3	40.5
CTC 80	36.5	14.5	10.5	10.7	33.3	26.9	31.9	49.1
CTC 100	39.1	18.4	10.5	10.7	40.3	36.1	41.1	58.3

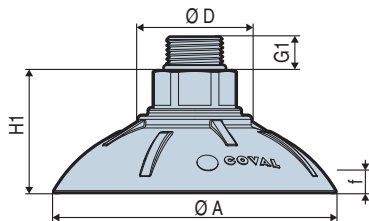

M38G Male fitting G3/8"

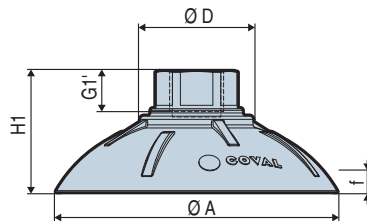

F38G Female fitting G3/8"

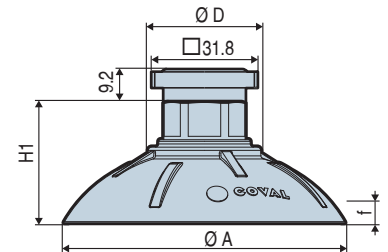

C32 Square coupling 32

Materials

SUCTION CUPS

- **TPU: Thermoplastic polyurethane, 85 shore A**
 - High resistance to oils and abrasion.
 - Operating temperature from -20° to 100°C (up to 120°C peak).

FITTINGS

- **PA: Polyamide filled with fiberglass (PA 6.6 30% FG)**, (fitting M38G/F38G).
- **AL: Aluminum (M38GA/F38GA/C32 Fitting)**.
- **O-ring (for M38G and C32 fittings): NBR Nitrile Blue.**

CTC 80 TPU M38G

DIAMETER		FITTING
Ø 40 mm	40	M38G G3/8"-M
Ø 60 mm	60	F38G G3/8"-F
Ø 80 mm	80	C32 C32
Ø 100 mm	100	

Example:
CTC80TPUM38G



VSA-VS BM

Suction Cups with Foam Ring Seals



Industry-specific applications

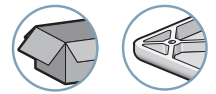

Types of use



The VSA and VS series suction cups equipped with VSBM foam rings are suitable for gripping products with rough surfaces. For example...

For applications requiring FDA food grade compatibility, see the suction cups with a silicone band, series VSA-VS BM-SIF.

- Sawn wood, sheet metal, flat surfaces with bumps or hollows.
- Any rough surfaces for which the suction cups' lips do not seal properly.

Materials

NBR Nitrile **SIT5** Translucent silicone **SI** Silicone

Specifications

Some suction cup models are available with a foam ring:

- **VSA series:** Standard 1.5 bellows suction cups, Ø 20 to 78 mm in nitrile (NBR) or in transparent silicone (SIT5).
- **VS series:** Standard 2.5 bellows suction cups, Ø 20 to 88 mm in nitrile (NBR) or in transparent silicone (SIT5).
- Foam ring in nitrile for nitrile suction cups (good resistance to oil).
- Foam ring in silicone (SI) for transparent suction cups (SIT5) and silicone glue. (Resistant up to 200°C and leaves no marks on gripped products. Do not use for gripping of products before painting or lacquering.)
- Assembling: foam rings are factory-bonded onto suction cup lips.

Suction Cups with 1.5 Bellows with Foam Ring Seals, VSA-BM series

Icon	Ø (mm)	Volume (cm³)	NBR		SIT5 / SI			
			Force (N) ⁽¹⁾	Part Nr.	Volume (cm³)	Force (N) ⁽¹⁾	Part Nr.	
	VSA 20---BM	20	1.3	7	VSA20NBRBM	1.3	4	VSA20SIT5BM
	VSA 25---BM	25	3.3	10	VSA25NBRBM	3.2	8	VSA25SIT5BM
	VSA 26---BM	26	4.2	10	VSA26NBRBM	4.1	8	VSA26SIT5BM
	VSA 33---BM	33	6.7	14	VSA33NBRBM	5.3	15	VSA33SIT5BM
	VSA 43---BM	43	12.3	25	VSA43NBRBM	10.8	26	VSA43SIT5BM
	VSA 53---BM	53	34.8	20	VSA53NBRBM	30.5	35	VSA53SIT5BM
	VSA 63---BM	63	52.9	40	VSA63NBRBM	45.9	50	VSA63SIT5BM
	VSA 78---BM	78	102.4	67	VSA78NBRBM	87.5	76	VSA78SIT5BM

Suction Cups with 1.5 Bellows



Foam Ring Seals

Suction Cups with 2.5 Bellows with Foam Ring Seals, VS-BM series

Icon	Ø (mm)	Volume (cm³)	NBR		SIT5 / SI			
			Force (N) ⁽¹⁾	Part Nr.	Volume (cm³)	Force (N) ⁽¹⁾	Part Nr.	
	VS 20---BM	20	2.4	5	VS20NBRBM	2.4	4.1	VS20SIT5BM
	VS 25---BM	25	5.7	9	VS25NBRBM	5.6	8	VS25SIT5BM
	VS 26---BM	26	6.5	9	VS26NBRBM	6.4	8	VS26SIT5BM
	VS 32---BM	32	11.9	11.2	VS32NBRBM	10.6	12.6	VS32SIT5BM
	VS 42---BM	42	22.6	23.4	VS42NBRBM	21.1	29	VS42SIT5BM
	VS 52---BM	52	44.6	32	VS52NBRBM	40.3	31.6	VS52SIT5BM
	VS 62---BM	62	86.4	37.5	VS62NBRBM	79.4	41	VS62SIT5BM
	VS 88---BM	88	201.3	93	VS88NBRBM	181.1	98.5	VS88SIT5BM

Suction Cups with 2.5 Bellows



Foam Ring Seals

(1) Actual force of the suction cup in use with a 65% vacuum and including a safety factor of 2 for horizontal handling.

VSA-VS BM

Suction Cups with Foam Ring Seals

Dimensions



Dimensions

VSA-BM 20-78

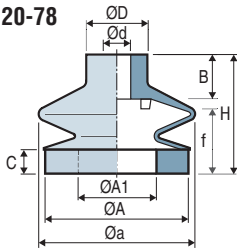

Suction Cup							NBR					SIT5 / SI				
	ØA	Øa	Ød	ØD	B	ØA1	C	H	f ⁽²⁾	⚖️ (g)	ØA1	C	H	f ⁽²⁾	⚖️ (g)	
VSA20 ... BM	20	20	4	10	9	10	2	18.2	6	1.8	10	2	18.2	6	1.8	
VSA25 ... BM	25	25	4	10	9	16	2	25.3	11.3	3.4	13	2	25.3	10.2	3.4	
VSA 26 ... BM	25	30	8	16	13	16	2	26.5	6.8	4.7	13	2	26.5	7.1	4.7	
VSA 33 ... BM	32	36.2	8	18	13	22	5	32.5	13.5	7.3	19	2	29.5	12.0	7.5	
VSA 43 ... BM	42	46	8	18	13	28	5	33	15.0	12.5	20	5	33	15.0	14	
VSA 53 ... BM	53	59	8	18	13	33	10	44	20.0	23.6	33	5	39	17.5	23.7	
VSA 63 ... BM	62	67	8	18	13	42	10	44	20.0	27.8	42	5	39	17.5	28.4	
VSA 78 ... BM	78	83	12	25	20	58	10	56.8	19.0	62.1	54	5	51.8	16.5	63.6	

VS-BM 20-88

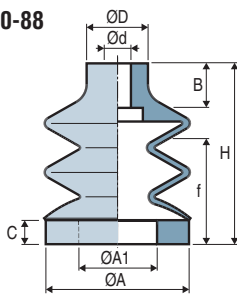

VS 20 ... BM	20	-	4	10	9	10	2	25	9.6	2.5	10	2	25	10	2.6
VS 25 ... BM	25	-	4	10	9	16	2	36.7	19.6	4.4	13	2	36.7	17.3	4.5
VS 26 ... BM	25	-	8	16	13	16	2	35	12.3	6.6	13	2	35	11.6	6.8
VS 32 ... BM	32	-	8	18	13	22	5	42.5	17.0	9.3	19	2	39.5	15.5	9.5
VS 42 ... BM	42	-	8	18	13	28	5	51	24.5	18.9	20	5	51	24.5	20.4
VS 52 ... BM	53	-	8	18	13	33	10	59	32.0	26.9	33	5	54	29.5	27
VS 62 ... BM	62	-	8	21	13	42	10	65	36.0	37.1	42	5	60	33.5	40.5
VS 88 ... BM	88	-	12	25	20	68	10	97.5	53.5	123.6	64	5	92.5	51.0	125.4

(2) f = Deflection of the suction cup.

Note: All dimensions are in mm.

The values represent the average characteristics of our products.



Please specify the part n°. e.g. VS42NBRBM
See part n° table above

Selection of fittings: please refer to fittings which are available in the suction cup series. **VSA** series: page 2/27, **VS** series: page 2/47.

VSA-VS BM-SIF

Suction Cups with Foam Ring Seals (Food-grade silicone FDA Standard)



Industry-specific application



Types of use



The standard VSA and VS suction cups series, equipped with the VSBM-SIF, are suitable for gripping products with an irregular or ridged surface, and are FDA-compliant.

- Flat surfaces with bumps or hollows.
- Any rough surfaces for which the suction cups' lips do not seal properly.

Materials

SIT5 50 Shore A translucent silicon

SIF Food-grade silicone FDA Standard

VSA-VS BM-SIF suction cups are compatible with FDA food standards (FDA 21 CFR 177.2600.).

Specifications

Some suction cup models are available with a foam ring:

- **VSA series:** Standard 1.5 bellows suction cups, Ø 20 to 78 mm in transparent silicone (SIT5).
- **VS series:** Standard 2.5 bellows suction cups, Ø 20 to 88 mm in transparent silicone (SIT5).
- Foam ring in silicone (SIF) for transparent suction cups (SIT5) and silicone glue. (Resistant up to 200°C and leaves no marks on gripped products. Do not use for gripping of products before painting or lacquering.)
- Assembling: foam rings are factory-bonded onto suction cup lips.

Suction Cup Properties

VSA Suction Cups with 1.5 Bellows					VS Suction Cups with 2.5 Bellows				
	Ø (mm)	cm ² (SIT5 / SIF)	(N) ⁽¹⁾	SIT5 / SIF		Ø (mm)	cm ² (SIT5 / SIF)	(N) ⁽¹⁾	SIT5 / SIF
VSA 20	20	1.3	4	VSA20SIT5BMSIF	VS 20	20	2.4	4.1	VS20SIT5BMSIF
VSA 25	25	3.2	8	VSA25SIT5BMSIF	VS 25	25	5.6	8	VS25SIT5BMSIF
VSA 26	26	4.1	6.7	VSA26SIT5BMSIF	VS 26	26	6.4	8	VS26SIT5BMSIF
VSA 33	33	5.3	15	VSA33SIT5BMSIF	VS 32	32	10.6	12.6	VS32SIT5BMSIF
VSA 43	43	10.8	26	VSA43SIT5BMSIF	VS 42	42	21.1	29	VS42SIT5BMSIF
VSA 53	53	30.5	35	VSA53SIT5BMSIF	VS 52	52	40.3	31.6	VS52SIT5BMSIF
VSA 63	63	45.9	50	VSA63SIT5BMSIF	VS 62	62	79.4	41	VS62SIT5BMSIF
VSA 78	78	87.5	76	VSA78SIT5BMSIF	VS 88	88	181.1	98.5	VS88SIT5BMSIF

(1) Actual force of the suction cup in use with a 65% vacuum and including a safety factor of 2 for horizontal handling.

Dimensions

VSA-BM 20-78

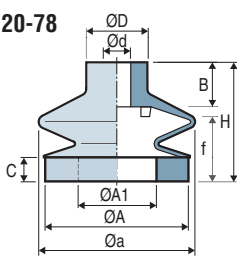

	ØA	Øa	Ød	ØD	B	ØA1	C	H	f ⁽²⁾	(g)
VSA20SIT5BMSIF	20	20	4	10	9	10	2	18	6.0	1.9
VSA25SIT5BMSIF	25	25	4	10	9	13	2	25	13.0	3.3
VSA26SIT5BMSIF	25	30	8	16	13	13	2	27	7.0	5
VSA33SIT5BMSIF	32	36.2	8	18	13	19	2	29.5	12.0	7.5
VSA43SIT5BMSIF	42	46	8	18	13	20	5	33	15.0	14
VSA53SIT5BMSIF	53	59	8	18	13	33	5	39	17.5	23.7
VSA63SIT5BMSIF	62	67	8	18	13	42	5	39	17.5	28.4
VSA78SIT5BMSIF	78	83	12	25	20	54	5	51.8	16.5	63.6

VS-BM 20-88

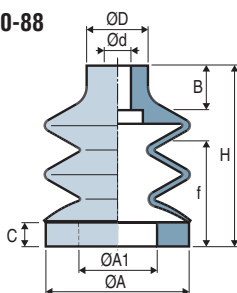

VS20SIT5BMSIF	20	-	4	10	9	10	2	25	11.0	2.6
VS25SIT5BMSIF	25	-	4	10	9	13	2	36	21.0	4.6
VS26SIT5BMSIF	25	-	8	16	13	13	2	33	12.0	6.6
VS32SIT5BMSIF	32	-	8	18	13	19	2	39.5	15.5	9.5
VS42SIT5BMSIF	42	-	8	18	13	20	5	51	24.5	20.4
VS52SIT5BMSIF	53	-	8	18	13	33	5	54	29.5	27
VS62SIT5BMSIF	62	-	8	21	13	42	5	60	33.5	40.5
VS88SIT5BMSIF	88	-	12	25	20	64	5	92.5	51.0	125.4

(2) f = Deflection of the suction cup.

Note: All dimensions are in mm.

The values represent the average characteristics of our products.



Please specify the part n°. e.g. **VS42SIT5BMSIF**
See part n° table above

Selection of fittings: please refer to fittings which are available in the suction cup series. **VSA series:** page 2/27, **VS series:** page 2/47.

VSBM

Foam Rings



The foam ring is designed for gripping products with an uneven or ridged surface, e.g.

- Sawn wood, sheet metal, flat surfaces with bumps or hollows.
- All granular surfaces to which suction cups cannot adhere correctly and therefore cannot be airtight.

Industry-specific applications



Types of use



Materials

NBR Nitrile **SI** Non Food-grade silicone **SIF** Food-grade silicone FDA Standard

2
VSBM

Operating Characteristics of the Materials

- Nitrile (NBR - Black)
5 or 10mm thick, depending on the diameters of the suction cups.
Good resistance to oil.
The nitrile foam strip can only be bonded to nitrile suction cups.
- Silicone (SI - White non Food-grade silicone, SIF - White Food-grade silicone FDA Standard)
2 or 5 mm thick, depending on the diameters of the suction cups.
Heat-resistant up to 200°C, does not leave marks on products handled.
Do not use the silicone foam strip for gripping products before painting or lacquering.
The silicone foam strip can only be bonded onto silicone suction cups (bonding is guaranteed if it is carried out in the factory).
- Mounting
The foam rings are mounted by bonding. In all cases, this should be performed in our factory as we have the adhesives adapted to the materials. It is essential that bonding of silicone be carried out in the COVAL factory.

Foam Ring Characteristics

NBR						SI / SIF					
Part Nr.	ØA	ØA1	C	f ⁽¹⁾	⚖️ (g)	Part Nr.	ØA	ØA1	C	f ⁽¹⁾	⚖️ (g)
VSBM32	32	22	5	2.5	0.3	VSBM20SI / SIF	20	10	2	1.0	0.2
VSBM42	42	28	5	2.5	0.7	VSBM25SI / SIF	25	13	2	1.0	0.4
VSBM53	53	33	10	5.0	2.7	VSBM32SI / SIF	32	19	2	1.0	0.5
VSBM62	62	42	10	5.0	2.8	VSBM42SI / SIF	42	20	5	2.5	2.2
VSBM78	78	58	10	5.0	3.7	VSBM53SI / SIF	53	33	5	2.5	2.8
VSBM88	88	68	10	5.0	4.6	VSBM62SI / SIF	62	42	5	2.5	3.4
						VSBM78SI / SIF	78	54	5	2.5	5.2
						VSBM88SI / SIF	88	64	5	2.5	6.4

Note: Suction cups with bellows are preferable when foam rings are required, as the slope of the lips is better suited to this type of grip. Please consult us for other models based on quantities.

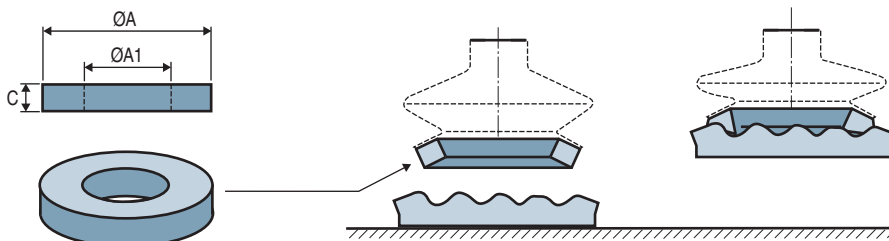

Please specify the part n°. e.g. VSBM32SI
See part n° table above

The values represent the average characteristics of our products.

(1) f = Deflection of the suction cup. Note: All dimensions are in mm.

Special Purpose Suction Cups

Chapter 3

3

Special Purpose Suction Cups

Thanks to its technological strength and collaboration with its customers in different industries, COVAL supplies a varied range of special purpose suction cups. E.g. handling eggs, CDs, bottles, paper, cakes, sheet metal at high speed, etc.

FPC FPCX



FlowPack Suction Cups

- Flexible suction cups
- 5 models
- Food-safe materials
- Silicone: FDA and CE standard
- Range specially designed for gripping flexible packaging
- Thin and wavy lips mold perfectly to any shape of packaging
- Gripping ability allows for high production rates

P_{3/4}

MVS



Soft Suction Cups for High Speed Applications

- Suction cups with 1.5 and 2.5 bellows
- 9 models
- Silicone: FDA and CE standard
- Used to grip delicate objects. Very flexible lip (opening bags, gripping tins and flexible aluminum or plastic bottles, etc.).
- High throughput rate
- Used to grip of flexible products

P_{3/7}

MVP



Suction Cups with 4.5 Bellows

- Suction cups with 4.5 bellows
- 4 diameters available: 20 to 50 mm
- Materials: nitrile and silicone (FDA and CE standards)
- The handling of raw food or flexible packaging
- Thin and flexible shaped lip for a perfect handling at high production rates
- The 4.5 bellows give a swivelling effect

P_{3/10}

VSAF



Suction Cup for Cheese

- Suction cup with 1.5 bellows
- Ø 50 mm
- Silicone: FDA and CE standard
- Suction cup specially designed for gripping fragile foods such as soft cheese
- Accessory: Stainless steel grid prevents deformation of the food

P_{3/13}

VSAOF



Oblong Suction Cup for Cheese

- Oval suction cup with 1.5 bellows
- Dim. 65x150 mm
- Silicone: FDA and CE standard
- Suction cup specially designed for gripping fragile foods such as soft cheese
- Accessory: Stainless steel grid prevents deformation of the food

P_{3/14}

VSD VSE VSP



Suction Cups For Bakery Applications

- Suction cups with 2.5 to 5.5 bellows
- 11 models
- Silicone: FDA and CE standard
- Range specially developed for gripping delicate objects such as cakes (buns, biscuits, etc.)
- Specific shapes and shore A hardness depending on the applications
- Resistance to temperature: -40 °C to +220 °C

P_{3/15}

Special Purpose Suction Cups

Chapter 3

3

VSO



Suction Cups for Egg-Handling

- Suction cups with 2.5 and 3.5 bellows
- 3 models
- Silicone: FDA and CE standard 1935/2004
- Range specially designed to meet constraints involved when handling eggs.
- Very flexible lip
- Different shapes of suction cup

P 3/17

VSBO VSBO+ VSBO LM/BM



Suction Cups for Bottle Handling

- Suction cups with 4.5 bellows
- 8 models
- High tensile force
- Highly flexible and long stroke
- Used to grip 750 ml bottles, Magnums bottles and special bottles with textured surfaces
- Bottles gripped from the side, vertical and horizontal handling
- Suction cup with stainless steel reinforcement in the bellows
- Available with integrated sensing valve

P 3/18

VBO



Suction Cup for Bottle Handling via the Punt

- Suction cup system comprised of a 62mm cup with 2.5 bellows and a silicone gripping disc (COVAL-Flex).
- The VBO suction cup system is designed for gripping bottles by the punt on disgorging stations.
- Excellent sealing when gripping different types of bottles.

P 3/27

VPBO



Coupler Plates for gripping bottles by the Punt

- Coupler Plates for gripping bottles by the punt
- 3 diameters: Ø65, 75 and 95 mm
- Natural rubber
- The VPBO Coupler Plates are designed for gripping bottles by the punt on disgorging stations (1/2 bottles, 75cl bottles and Magnum)

P 3/28

VPA



Suction Cups for Paper Applications

- Flat suction cups
- 9 models
- Very flexible lip
- Materials: natural rubber and silicone (food compatibility)
- Range of suction cups with very flexible lip used to handle very flexible materials
- Very resistant to abrasion (for paper, cardboard)
- Very flexible gripping lip which molds to the shape of the object to be handled

P 3/29

VPAL

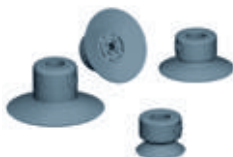

Suction Cups for Labels

- Extra-flat shape suction cups
- 3 models
- Material: silicone (food compatibility)
- The VPAL suction cups are especially adapted for gripping and handling IML labels or flexible materials
- Great lip flexibility

P 3/31

VSAPL



Suction Cups with 1.5 Bellows for Labels

- Suction cup with 1.5 bellows
- Ø 11 mm
- Silicone: FDA and CE standard
- The VSAPL suction cup is especially adapted for gripping and handling IML labels or flexible materials
- Great lip flexibility

P 3/32

Special Purpose Suction Cups

Chapter 3

3

VPR



Suction Cups for Mailing Applications

- Flat suction cups
- 4 models
- Material: natural rubber
- Range of suction cups designed to meet the requirements of mailing applications
- Envelope stuffing, film-wrapping, mailing (picking)
- Very resistant to abrasion

P 3/33

VPAG



Curved Suction Cups

- Curved suction cups
- 2 models
- Material: natural rubber
- Thanks to very flexible lips and a curved shape, the VPAG range is adapted to gripping flexible materials such as labels or sheets of paper - or textured objects
- Very resistant to abrasion

P 3/34

VPSC



Ultra-flat, Non-Marking Suction Cups

- Ultra flat suction cups
- Ø 40 and 80 mm
- Materials : Polyurethane and silicone (FDA and CE standards)
- Suction cup specially designed not to deform the gripped product.
- Vacuum distributed across the entire surface of the suction cup for optimal gripping force.
- Extra-thin sealing lip designed to contour to the shape of the product being handled

P 3/35

VPYR



Radial Ball-joint Suction Cups

- Flat suction cups with radial ball-joint system
- 4 models (Ø50 to 100mm)
- Materials: nitrile and silicone
- The range of ball-joint suction cups is recommended for gripping curved or rotating products which requires a lot of force and mechanical resistance

P 3/36

SPL



Heavy Load Suction Cups

- "Heavy load" flat suction cups
- 5 models (Ø240 to 600mm)
- Materials: nitrile and silicone
- SPL suction cups are used to handle heavy loads such as sheet metal or glass panels. They have internal cleats allowing them to handle thin metal sheets without distorting them and for vertical handling (non-slip)

P 3/37

STEEL



Steel Suction Cups

- Flat suction cups with a bonded foam seal
- 9 round models (Ø 150 to 580 mm)
- 9 rectangular models (175x115 to 705x385mm)
- For horizontal handling of heavy loads (thick sheet metal) or objects with an uneven surface such as concrete slabs, wood, etc.
- Wide choice of dimensions

P 3/38

FPC/FPCX

FlowPack Suction Cups



Combining great flexibility and food compatibility, the new FPC and FPCX Series suction cups have been specially designed to optimize the handling of packed bags from 100 g to 5 kg. E.g. - FlowPack, DoyPack, etc.

- Its gripping ability allows for high production rates.
- No interruption in the packaging line due to faulty gripping.
- Suction cup made of silicone, a material that is recommended for its temperature resistance and food safety (FDA and CE 1935/2004).
- Energy Savings: the airtightness of FPC and FPCX Series suction cups avoids the need for an oversized vacuum generator.

Different forms and dimensions for a suitable solution.

- Round Ø 35 1.5 bellows, Round Ø 45 and Ø 60 mm or elliptical 120 x 100 mm.

Applications

The FPC and FPCX series suction cups are dedicated to the handling of flexible packaging such as FlowPack, Doypack, etc. :

- FlowPack < 0.5 kg: suction cup Ø 35 mm, FPC351.5.
- FlowPack < 1 kg: suction cup Ø 45 mm, FPC45.
- FlowPack < 1.5kg: suction cup Ø 60 mm, FPC60/ FPCX60.
- FlowPack ≤ 5 kg: elliptical suction cup 120x100 mm, FPC120100.

Industry-specific application

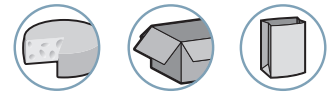

Types of use



Materials

Suction cups:	SIBL3 Blue silicone 35 Shore A
	SIBL5 Blue silicone 50 Shore A
Fittings:	Plastic POM-C and PETP
Flat seal:	Silicone
Screw:	Stainless steel

FPC and FPCX suction cups are compatible with FDA food standards (FDA 21 CFR 177.2600.) and meet the European regulation (EC) 1935/2004.

Innovations

The shape of the lip has been designed to match the deformation of flexible packaging and ensure the best possible seal during positioning; which, as an additional advantage, allows for a reduction in power of the vacuum generator. The FPC/FPCX suction cups are also equipped with cleats that stiffen the lip and reinforce the clamping effect.

- 1 Thin and wavy fl wer-shaped lips that perfectly mold to the packaging, whatever the shape.
- 2 Internal cleats that allow for optimized vacuum while preventing any crushing and also strengthen the hold on the product being handled.
- 3 Fittings featuring a lateral vacuum distributor that prevent any loss in efficiency when the product is held.
- 4 Materials: Food-grade silicone and plastic insert meets FDA and CE standards.

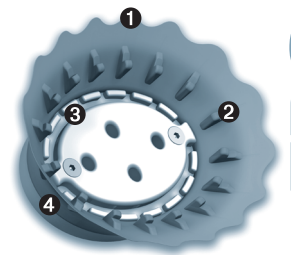

FPCX60SIBL5: A variant of the FPC60SIBL5 suction cup is available with a slightly thicker lip, providing it with greater durability over time

Suction Cup characteristics

Image	Dim. (mm)	Volume (cm³)	Force (N) (1)	SIBL3	SIBL5
				Part number suction cup + fittin	Part number suction cup + fittin
	Ø 35	7.2	5	FPC351.5SIBL3IF14PC	FPC351.5SIBL5IF14PC
	Ø 45	13	10	FPC45SIBL3IF38PC	FPC45SIBL5IF38PC
	Ø 60	24.5	15	FPC60SIBL3IF38PC	FPC60SIBL5IF38PC
	Ø 60	24.5	15	-	FPCX60SIBL5IF38PC
	120x100	167	50	FPC120100SIBL3IF38P1V	FPC120100SIBL5IF38P1V

(1) Force measured at 65% vacuum, without safety factor.

Range

FPC351.5...IF14PC
Round Ø 35 mm
1.5 bellows

FPC45...IF38PC
Round Ø 45 mm

FPC60...IF38PC
Round Ø 60 mm

FPCX60...IF38PC
Round Ø 60 mm

FPC120100...IF38P1V
Elliptical 120 x 100 mm

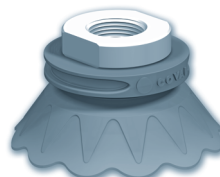

Specify the part number e.g.: FPC60SIBL3IF38PC
Please refer to the characteristics table above

FPC/FPCX

FlowPack Suction Cups

Dimensions

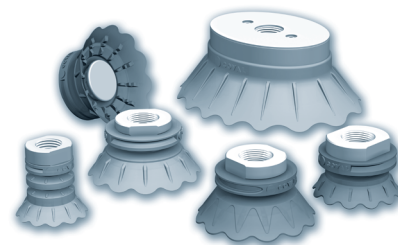

Suction Cup + fittin

FPC351.5---IF14PC

Round, Ø 35 mm, 1.5 bellows

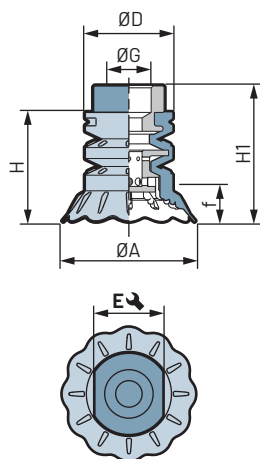

FPC45---IF38PC

FPC60/FPCX60---IF38PC

Round, Ø 45 and 60 mm

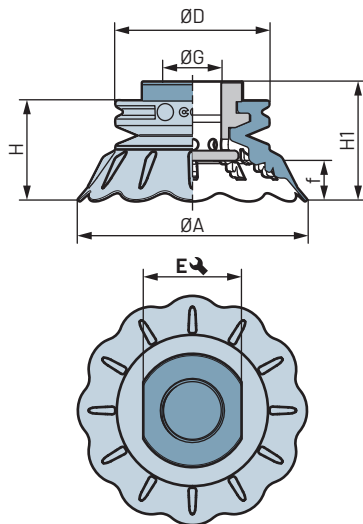

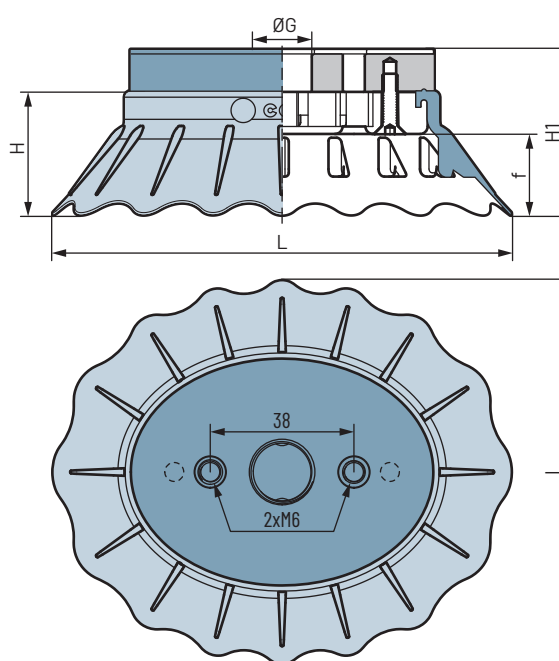

FPC120100---IF38P1V

Elliptical, 120 x 100 mm



3 FPC/FPCX

	Ø A	Ø D	L	I	f ⁽¹⁾	H	H1	Ø G	E ↺	 (g)
FPC351.5---IF14PC	35	23	-	-	10	29	36	G1/4"-F	19	9.9
FPC45---IF38PC	45	39	-	-	7	23	30	G3/8"-F	26	20
FPC60---IF38PC	60	40	-	-	10	26	33	G3/8"-F	26	21.5
FPCX60---IF38PC	60	40	-	-	10	26	33	G3/8"-F	26	21.5
FPC120100---IF38P1V	-	-	120	100	15	32.5	42.5	G3/8"-F	-	92.1

(1) f = Deflection of the suction cup

Mounting Configurations

FPC351.5/FPC45/FPC60/FPCX60

Via connection:

- FPC351.5: G1/4"-F
- FPC45/FPC60/FPCX60: G3/8"-F

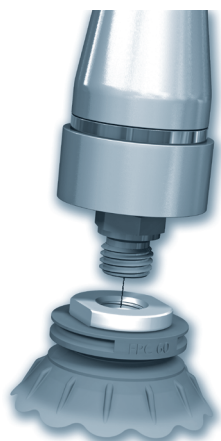

FPC120100

From below:

2 M5x20 screws (not included)

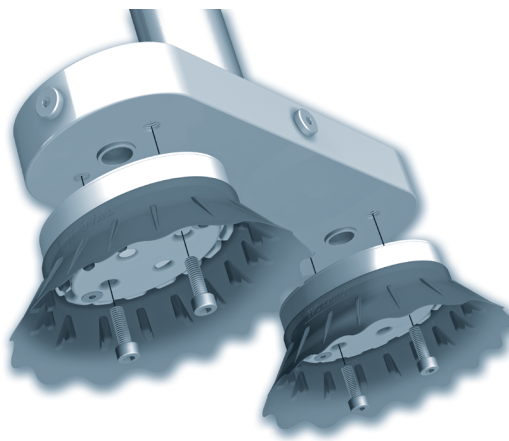

From above:

2 M6x16 screws (not included)

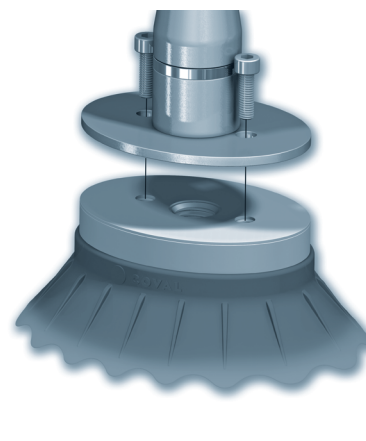

The values represent the average characteristics of our products.
Note: All dimensions are in mm

FPC/FPCX

FlowPack Suction Cups Part Configurations



FPC351.5

Round, Ø 35 mm, 1.5 bellows
COMPLETE PART CONFIGURATION

SUCTION CUP
+
UPPER G1/4"-F FITTING
+
LOWER PLATE

- Hardness 35 Shore
FPC351.5SIBL3IF14PC
- Hardness 50 Shore
FPC351.5SIBL5IF14PC



INDIVIDUAL PART REFERENCE

UPPER G1/4"-F FITTING ONLY:
IF14PFPC35

SUCTION CUP ONLY:
■ Hardness 35 Shore
FPC351.5SIBL3
■ Hardness 50 Shore
FPC351.5SIBL5

LOWER PLATE ONLY:
IL1PFPC35

FPC45/FPC60/FPCX60

Round, Ø 45 and 60 mm
COMPLETE PART CONFIGURATION

SUCTION CUP
+
G3/8"-F FITTING:

FPC45

- Hardness 35 Shore
FPC45SIBL3IF38PC
- Hardness 50 Shore
FPC45SIBL5IF38PC

FPC60

- Hardness 35 Shore
FPC60SIBL3IF38PC
- Hardness 50 Shore
FPC60SIBL5IF38PC

FPCX60

- Hardness 35 Shore
FPCX60SIBL5IF38PC

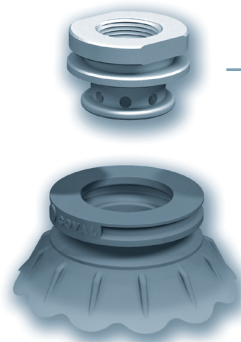

INDIVIDUAL PART REFERENCE

UPPER G3/8"-F ONLY:
IF38PFPC60

FPC45

SUCTION CUP ONLY:
■ Hardness 35 Shore
FPC45SIBL3
■ Hardness 50 Shore
FPC45SIBL5

FPC60

SUCTION CUP ONLY:
■ Hardness 35 Shore
FPC60SIBL3
■ Hardness 50 Shore
FPC60SIBL5

FPCX60

■ Hardness 50 Shore
FPCX60SIBL5

FPC120100

Elliptical, 120 x 100 mm
RÉFÉRENCE DES VENTOUSES COMPLÈTES

SUCTION CUP
+
LOWER PLATE
+
UPPER PLATE G3/8"-F
+
FLAT SEAL:

- Hardness 35 Shore
FPC120100SIBL3IF38P1V
- Hardness 50 Shore
FPC120100SIBL5IF38P1V

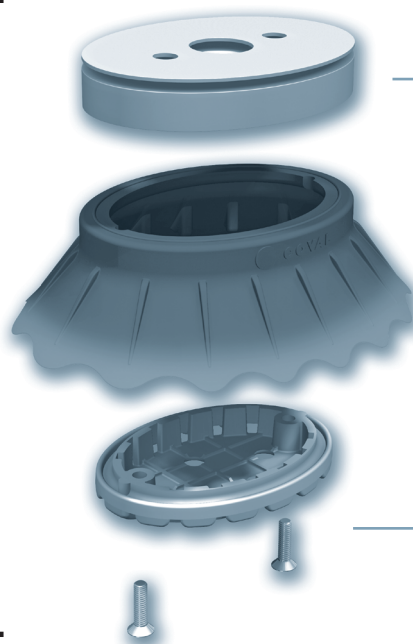

INDIVIDUAL PART REFERENCE

UPPER PLATE G3/8"-F + FLAT SEAL:
IF38PFPC120

SUCTION CUP ONLY:
■ Hardness 35 Shore
FPC120100SIBL3
■ Hardness 50 Shore
FPC120100SIBL5

LOWER PLATE + 2 STAINLESS SCREWS M4x16:
IL1PFPC120

Standard configurations (suction cup + fitting) are delivered unassembled.

Soft Suction Cups for High Speed Applications



Industry-specific application

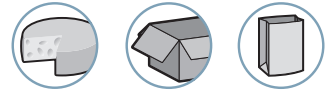

Types of use



COVAL has designed a range of high performance cups in order to meet demanding industry requirements for gripping soft or flexible products at high speeds.

- Soft, thin sealing lip and optional cleats provide a perfect grip during high work rates for all types of flexible shapes and materials.
- Food-grade silicone meets FDA and CE 1935/2004 standards.
- Available in 1.5, 2.5 and 3.5 bellows.
- Available in Ø 20-40 mm.

Applications

This flexibility allows for high speed gripping of all types of materials and foods: FlowPack, DoyPack, thermoformed food trays, raw materials (sausage, fresh fish, cookies, chocolates)... Speeds of 120 or more grip and release cycles per minute.

Materials

SIB 35 Shore A white silicone

SIT5 50 Shore A Translucent silicone

Suction Cup Characteristics

Suction Cup Icon	Ø (mm)	Volume (cm ³)	Holding Force (N) ⁽¹⁾	Silicone		Aluminum fittings		FDA fittings		
				Reference	Reference	G1/4"-M	G1/4"-F	G1/4"-M	G1/4"-F	G1/8"-M
	20	4	3.1	MVS202.5SIBG	MVS202.5SIT5G	-	-	-	-	IM18SP1251
	20	4	3.3	MVS202.5SIBC	MVS202.5SIT5C	-	-	-	-	IM18SP1251
	30	7	7.8	MVS301.5SIBG	MVS301.5SIT5G	IM51SP143	IF50SP143	IM14PMVS30	IF14PMVS30	-
	30	7	10.1	MVS301.5SIBC	MVS301.5SIT5C	IM51SP143	IF50SP143	IM14PMVS30	IF14PMVS30	-
	30	11.2	7.6	MVS302.5SIBG	MVS302.5SIT5G	IM51SP143	IF50SP143	IM14PMVS30	IF14PMVS30	-
	30	11.2	8.5	MVS302.5SIBC	MVS302.5SIT5C	IM51SP143	IF50SP143	IM14PMVS30	IF14PMVS30	-
	30	11.6	8.4	MVS303.5SIBC	-	IM51SP143	IF50SP143	IM14PMVS30	IF14PMVS30	-
	40	7.3	12.7	MVS401.5SIBC	MVS401.5SIT5C	IM51SP143	IF50SP143	-	-	-
	40	13	8.2	MVS402.5SIBC	MVS402.5SIT5C	IM51SP143	IF50SP143	-	-	-

(1) Actual holding force of the suction cup at a vacuum of 65% on flat and smooth surface and safety factor of 2 included.

MVS---G



MVS---C



For applications requiring suction cups with a smaller diameter, we recommend the VSA series in the SIB version, see page 2/27.



Specify the part number e.g.: **MVS302.5SIBC**
Please refer to the characteristics table above

Note: Nozzle fitting IM5M S see page 4/10.

Accessories

To optimize the use of your suction cups, Coval offers a comprehensive range of accessories (nozzle fittings, spring extensions, and feeder systems, etc.), see chapters 4 and 14.



Suction Cups

MVS202.5...G

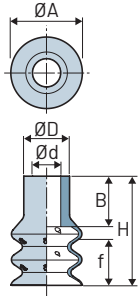

MVS202.5...C

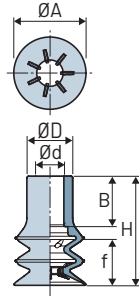

MVS301.5...G

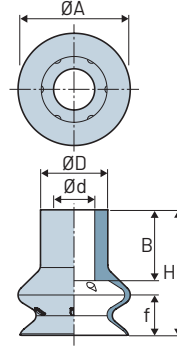

MVS301.5...C

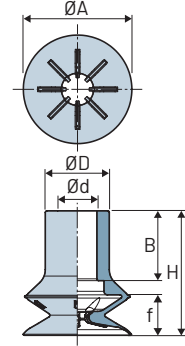

MVS302.5...G

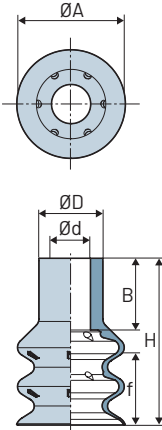

MVS302.5...C

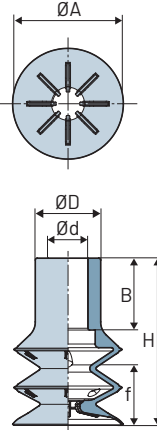

MVS303.5...C

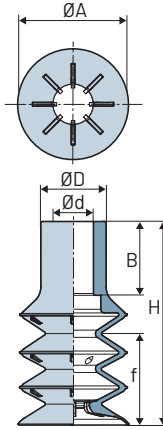

MVS401.5...C

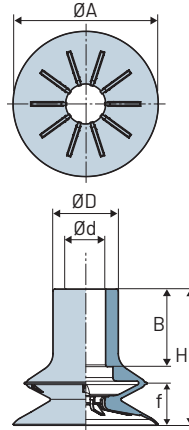

MVS402.5...C

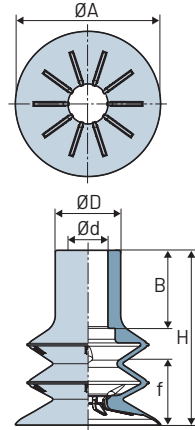

	Ø A	H	Ø d	Ø D	f ⁽²⁾	B	(g)
MVS202.5...G	20	31	8	13	10	13	2.3
MVS202.5...C	20	31	8	13	10	13	3
MVS301.5...G	30	35	11	18	10	19.5	5.9
MVS301.5...C	30	35	11	18	9	19.5	6.5
MVS302.5...G	30	46	11	18	17.5	19.5	6.8
MVS302.5...C	30	46	11	18	15.5	19.5	8.2
MVS303.5...C	30	56	11	18	22.5	20.6	9.4
MVS401.5...C	40	37.5	11	18	7	21.5	8.7
MVS402.5...C	40	48	11	18	15.5	21.5	10.5

(2) f = Deflection of the suction cup.

Barbed Fittings

Male fittings

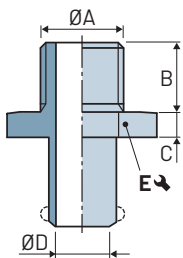

Female fittings

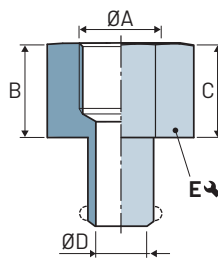

	Ø A	B	C	Ø D	E	Materials	(g)
IM 18 SP1251	G1/8"-M	8	5	4.8	14	POM-C	2.5
IM 51 SP143	G1/4"-M	11	6	8	21	Aluminum	10.5
IF 50 SP143	G1/4"-F	10	15	8	21	Aluminum	14.4
IM 14 P MVS30	G1/4"-M	11	6	8	21	POM-C	5.2
IF 14 P MVS30	G1/4"-F	12.5	17	8	21	POM-C	8.3

The values represent the average characteristics of our products.

Note: All dimensions are in mm

Suction Cups with 4.5 Bellows



The MVP series suction cups are designed to the handling of raw food or flexible packaging at high speeds. The thin gripping lip allows to fit with the product to be handled and the 4.5 bellows give a swivelling effect to ensure the positioning of the suction cup when the product is held. Furthermore, once in grip, the rigidity of the compressed bellows ensures a very good prehension of the object and avoids the swing effect.

- Thin and flexible shaped lip for a perfect handling at high production rates
- 4.5 bellows
- Ø 20-30-40-50 mm
- Available in 3 materials:
 - Blue Silicone (SIBL5) to meet FDA and CE 1935/2004 standards.
 - Detectable Blue Silicone (SI5BD), load with 30% of detectable particles and meets the CE 1935/2004 standards.
 - Nitrile (NBR)
- Fittings available with or without inner filtering grid.
- Male fittings (IM) equipped with O-ring sealing

Applications

The high flexibility of the MVP suction cups lips allows to handle at great speed all kind of materials or foodstuff: Flowpack, Doypack, pouch bags, thermoformed trays, raw products (sausage, fresh fish, biscuits, chocolates)...

Industry-specific applications

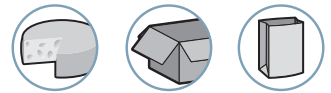

Types of use





Materials

NBR Nitrile

SIBL5 Blue silicone 50 shore A

SI5BD Blue silicone 50 shore A detectable

Suction Cup Characteristics

	Ø (mm)	 (cm ³)	 (N) ⁽¹⁾	NBR	SIBL5	SI5BD
MVP204.5	20	3.2	4.3	MVP204.5NBR	MVP204.5SIBL5	MVP204.5SI5BD(*)
MVP304.5	30	11.6	12.5	MVP304.5NBR	MVP304.5SIBL5	MVP304.5SI5BD(*)
MVP404.5	40	25.3	16.5	MVP404.5NBR	MVP404.5SIBL5	MVP404.5SI5BD(*)
MVP504.5	50	50.4	27.8	MVP504.5NBR	MVP504.5SIBL5	MVP504.5SI5BD(*)

(1) Actual holding force of the suction cup at a vacuum of 65% on flat and smooth surface and safety factor of 2 included.

(*) On request

Choice of Fittings

 (Ø)	G1/8"-M	G1/8"-F	G1/4"-M	G3/8"-M
20	■	-	-	-
30	-	■	■	■
40	-	■	■	■
50	-	-	■	■

■ Standard available configurations (suction cup + fitting) Fitting: M = male F = female refer to page 3/11

Type of Assembly



Version E: Pressed fitting



Specify the part number e.g.: MVP304.5SIBL5
Please refer to the characteristics table above



MVP 3

References - "Suction Cup + Fitting"

Ø 20 mm	G1/8"-M	
	Fitting with filter	Fitting without filter
	MVP204.5NBR	MVP204.5NBRIM18F MVP204.5NBRIM18
	MVP204.5SIBL5	MVP204.5SIBL5IM18F MVP204.5SIBL5IM18
MVP204.5SI5BD	on request	on request

Ø 30 - 40 mm	G1/8"-F		G1/4"-M		G3/8"-M	
	Fitting with filter	Fitting without filter	Fitting with filter	Fitting without filter	Fitting with filter	Fitting without filter
	MVP304.5NBR	MVP304.5NBRIF18F MVP304.5NBRIF18	MVP304.5NBRIM14F MVP304.5NBRIM14	MVP304.5NBRIM38F MVP304.5NBRIM38		
	MVP304.5SIBL5	MVP304.5SIBL5IF18F MVP304.5SIBL5IF18	MVP304.5SIBL5IM14F MVP304.5SIBL5IM14	MVP304.5SIBL5IM38F MVP304.5SIBL5IM38		
	MVP304.5SI5BD	on request	on request	on request		
	MVP404.5NBR	MVP404.5NBRIF18F MVP404.5NBRIF18	MVP404.5NBRIM14F MVP404.5NBRIM14	MVP404.5NBRIM38F MVP404.5NBRIM38		
	MVP404.5SIBL5	MVP404.5SIBL5IF18F MVP404.5SIBL5IF18	MVP404.5SIBL5IM14F MVP404.5SIBL5IM14	MVP404.5SIBL5IM38F MVP404.5SIBL5IM38		
	MVP404.5SI5BD	on request	on request	on request		

Ø 50 mm	G1/4"-M		G3/8"-M	
	Fitting with filter	Fitting without filter	Fitting with filter	Fitting without filter
	MVP504.5NBR	MVP504.5NBRIM14F MVP504.5NBRIM14	MVP504.5NBRIM38F MVP504.5NBRIM38	
	MVP504.5SIBL5	MVP504.5SIBL5IM14F MVP504.5SIBL5IM14	MVP504.5SIBL5IM38F MVP504.5SIBL5IM38	
MVP504.5SI5BD	on request	on request	on request	

Dimensions «Suction Cup + Fitting»

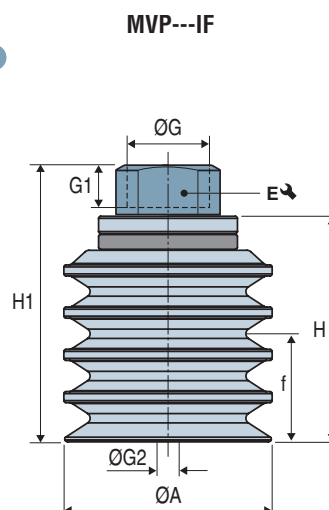
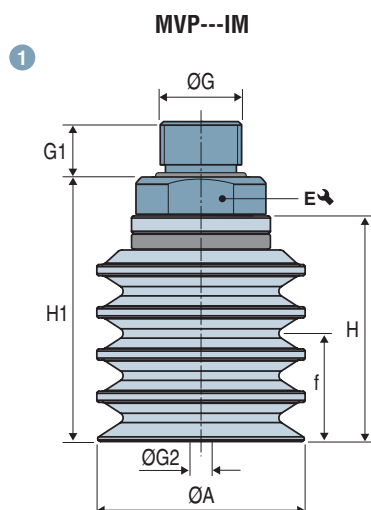

	Diagram	ØA	f ⁽¹⁾	H	H1	ØG	G1	ØG2 ⁽²⁾	E ↺	⊞ (g)
MVP204.5...IM18-	1	20	13.2	22.3	27.3	G1/8"-M	7	4	13	5.3
MVP304.5...IF18-	2	30	20.2	32.5	40.5	G1/8"-F	6.6	5	17	11.5
MVP304.5...IM14-	1	30	20.2	32.5	38.5	G1/4"-M	9	5	19	12.4
MVP304.5...IM38-	1	30	20.2	32.5	38.5	G3/8"-M	10	5	22	17
MVP404.5...IF18-	2	40	27	41.2	49.2	G1/8"-F	6.6	5	17	18.8
MVP404.5...IM14-	1	40	27	41.2	47.2	G1/4"-M	9	5	19	19.7
MVP404.5...IM38-	1	40	27	41.2	47.2	G3/8"-M	10	5	22	24.3
MVP504.5...IM14-	1	50	32.8	52.1	58.1	G1/4"-M	9	6	22	35.6
MVP504.5...IM38-	1	50	32.8	52.1	58.1	G3/8"-M	10	6	23.9	38.6

Note: All dimensions are in mm.

(1) f = Deflection of the suction cup.

(2) Ø G2 = Ø internal orifice of the fitting.



Assembly Diagrams

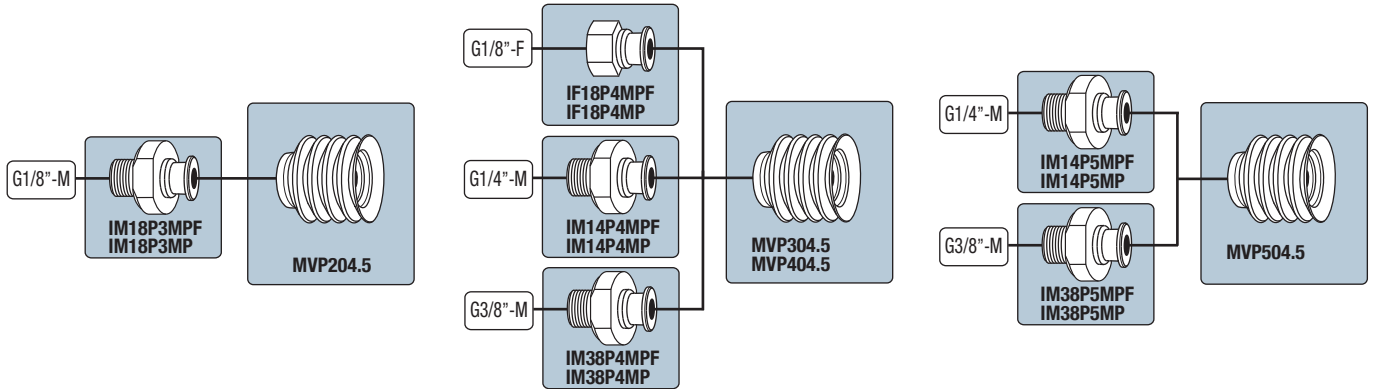

Dimensions Suction Cups

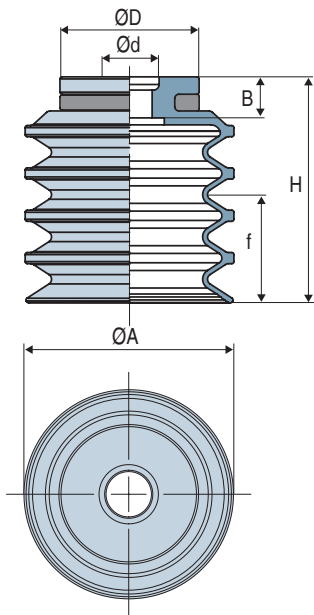

	ØA	H	Ød	ØD	f ⁽²⁾	B	⚖ (g)
MVP204.5	20	22.3	6	14	13.2	4.8	2.1
MVP304.5	30	32.5	6.5	20	20.2	6.9	5.4
MVP404.5	40	41.2	6.5	19.5	27	6.9	12.7
MVP504.5	50	52.1	6.5	27	32.8	9.9	23.5

(2) f = Deflection of the suction cup.

Dimensions Fittings

Male fittings

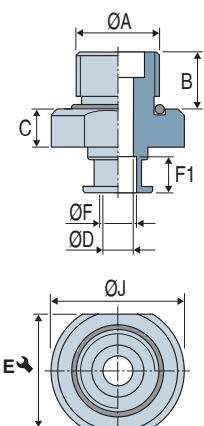

Female fittings

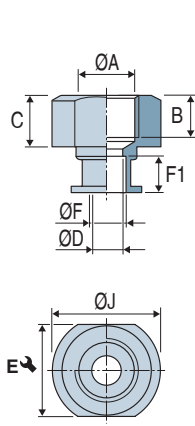

Fitting with stainless steel filter 200 µm	Fitting without filter	ØA	B	C	ØD	E ↘	ØJ	ØF	F1	Materials Fitting*	⚖ (g)
IM18P3MPF	IM18P3MP	G1/8"-M	7	5	4	13	15	5	4.7	Aluminum	3.2
IF18P4MPF	IF18P4MP	G1/8"-F	6.6	8	5	17	20	6	5.7	Aluminum	6.1
IM14P4MPF	IM14P4MP	G1/4"-M	9	6	5	19	21	6	5.7	Aluminum	7
IM14P5MPF	IM14P5MP	G1/4"-M	9	6	6	22	28	10	8.7	Aluminum	12.1
IM38P4MPF	IM38P4MP	G3/8"-M	10	6	5	22	24	6	5.7	Aluminum	11.6
IM38P5MPF	IM38P5MP	G3/8"-M	10	6	6	23.9	28	10	8.7	Aluminum	15.1

*Male fittings (IM) equipped with O-ring sealing

The values represent the average characteristics of our products.
Note: All dimensions are in mm

VSAF

Suction cup with 1.5 bellow Specifically designed for cheese

To meet the requirements of applications for handling soft and fragile food products such as soft cheese, COVAL has developed a 1.5 bellow suction cup made of food-grade silicone that can be fitted with a stainless steel grid, which prevents deforming the food product.

- Suction cup made of 50 Shore A blue silicone that complies with food standards (FDA and CE 1935/2004).
- 1.5 bellow
- Ø 50 mm



Industry-specific applications



Types of use





3

Materials

SIBL5 50 Shore A blue silicone

Suction Cup Characteristics

	Ø (mm)	 (cm ³)	 (N) ⁽¹⁾
VSAF50SIBL5	50	24.1	19

(1) Actual force of suction cup in use with 20% vacuum and including a safety factor of 2.

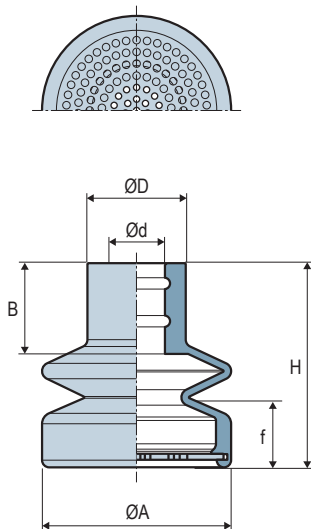

Dimensions

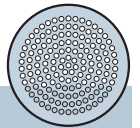

Accessory

Stainless steel grid 50 mm in diameter for suction cup VSAF50:
Part no.: 80002171
Weight: 18 g



	Ø A	H	Ø d	Ø D	B	f ⁽²⁾	 (g)
VSAF50SIBL5	50	54	15	26	24	11	28

(2) f = Deflection of suction cup.



Specify the part number: **VSAF50SIBL5**
+ stainless steel grid Part no. 80002171

The values represent the average characteristics of our products.
Note: All dimensions are in mm

VSAOF

Oblong suction cup with 1.5 bellow Specifically designed for cheese



Industry-specific applications



Types of use





To meet the requirements of applications for handling soft and fragile food products such as soft cheese, COVAL has developed a 1.5 bellow oblong suction cup made of food-grade silicone that can be fitted with a stainless steel grid, which prevents deforming the food product.

- Suction cup made of 50 Shore A blue silicone that complies with food standards (FDA and CE 1935/2004).
- 1.5 bellow
- Dimensions: 65 x 150 mm

Materials

SIBL5 50 Shore A blue silicone

Suction Cup Characteristics

	Dim. (mm)	 (cm ³)	 (N) ⁽¹⁾
VSAOF65150SIBL5	65x150	298	51.5

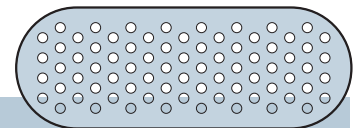
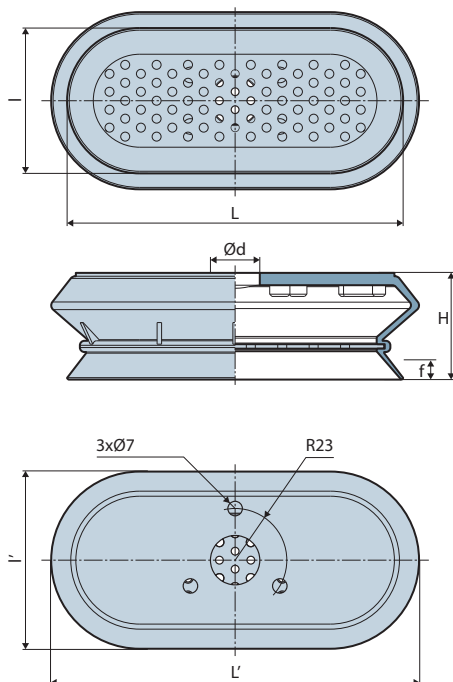

(1) Actual force of suction cup in use with 20% vacuum and including a safety factor of 2.

Dimensions



Accessory

Stainless steel grid for suction cup
VSAOF65150:
Part no.: 80002470
Weight: 80 g

	L	I	L'	I	Ø d	f ⁽²⁾	 (g)
VSAOF65150SIBL5	149.8	64.8	164	79	22	26	124

(2) f = Deflection of suction cup.



Specify the part number: **VSAOF65150SIBL5**
+ stainless steel grid Part no. 80002470

The values represent the average characteristics of our products.
Note: All dimensions are in mm

VSD, VSE, VSP

Suction Cups for Bakery Applications



Suction cups specially developed for gripping delicate objects such as cakes (buns, biscuits, etc.). Specific shape and shore hardness options are available depending on the application. Food-grade silicone (FDA and CE 1935/2004) allows the suction cups to be used at temperatures between - 40 °C to + 220 °C (-40 °F to 428 °F).

Industry-specific applications

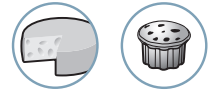

Types of use



Materials

Si Silicone	SIT3 35 Shore A translucent silicone
SI3 35 Shore A silicone	SIT5 50 Shore A translucent silicone
SI5 50 Shore A silicone	SIT6 60 Shore A translucent silicone

Suction Cup Characteristics

Icon	dim. (mm)	f ⁽¹⁾	maximum vacuum (%)	shore hardness	⚖️ (g)	Fittings	
						M5-M	G1/8"-M
	Ø 25	24	90	30	6.5	-	-
	Ø 37	21	20	50	6.3	-	-
	Ø 35	26	20	30	8.8	-	-
	Ø 35	26	30	50	8.8	-	-
	Ø 39	28	30	50	11.5	-	-
	Ø 14	9	70	35 ⁽²⁾	0.9	IM21SP139	IM11ASP139
	Ø 14	9	90	60	0.9	IM21SP139	IM11ASP139
	22 x 58	8	20	50	12.5	-	-
	27 x 47	26	15	30	9.8	-	-
	38 x 56	28	15	50	11.8	-	-
	23 x 76	14	15	50	13.5	-	-

(1) f = Deflection of the suction cup. (2) Non-toxic red silicone

Suction Cup Dimensions

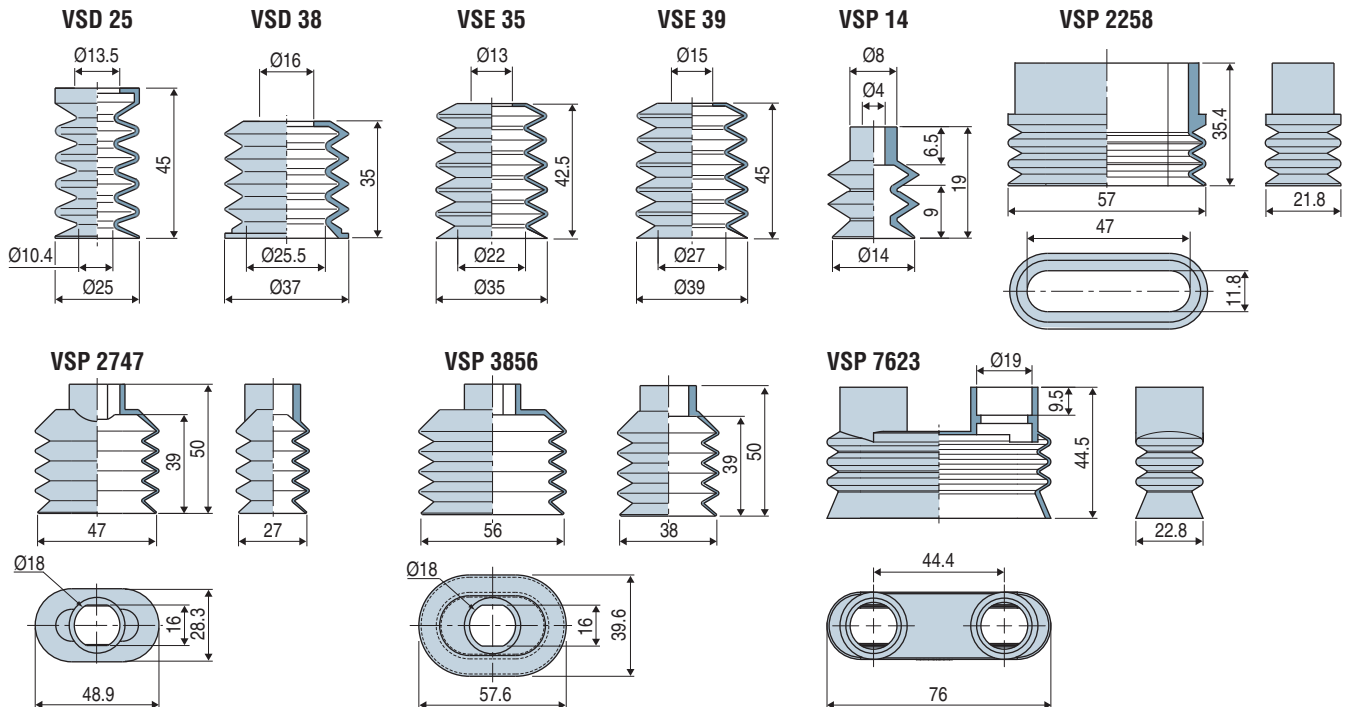

The values represent the average characteristics of our products.
Note: All dimensions are in mm

Accessories

To optimize the use of your suction cups, Coval offers a comprehensive range of accessories (nozzle fittings, spring extensions, and feeder systems, etc.), see chapters 4 and 14.



Specify the part number e.g.: **VSP14SIT6**
Please refer to the characteristics table above

3 VSD, VSE, VSP

VSD, VSE, VSP

Suction Cups for Bakery Applications



Barbed Fittings

Male - IM

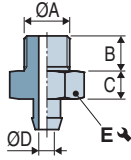

	ØA	B	C	ØD	E ↘	Material	⚖ (g)
IM 11 ASP 139	G1/8"-M	7.5	6	3.5	14	Aluminum	4.1
IM 21 SP 139	M5-M	4.5	5	2.5	7	Brass	2.8



Industry-specific applications



Types of use



The VSO range of suction cups has been specially designed to meet the constraints involved when handling eggs.

- Very flexible lip
- Different shapes of suction cup
- Food-grade silicone meets FDA and CE 1935/2004 standards.

Materials

SI 35 Shore A red silicone



SIT3 35 Shore A translucent silicone

SIT5 50 Shore A translucent silicone

3

VSO



Suction Cup Characteristics

	Ø (mm)	 (cm ³)	 (N) ⁽¹⁾	SI	SIT3	SIT5
VSO 30	30	40	1.1	VS030SI	-	-
VSO 33	33	13	1.1	-	-	VS033SIT5
VSO 36	36	34	1.1	-	VS036SIT3	-

(1) at 30% vacuum with a safety factor of 2 included.

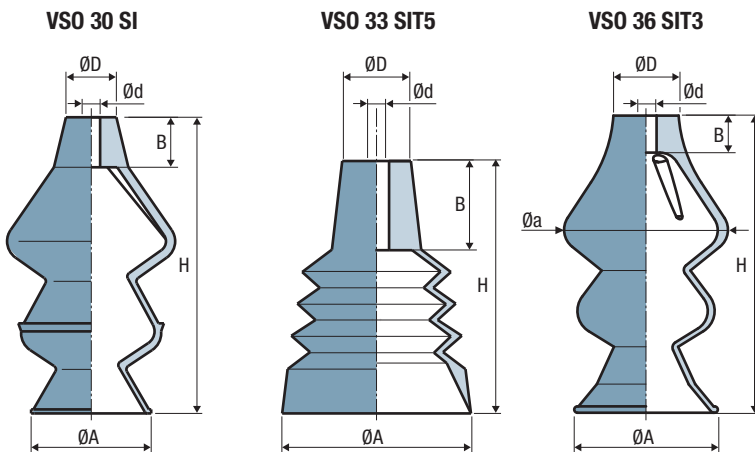
Suction Cup Dimensions



	Ø A	H	Ø a	Ø d	Ø D	B	 (g)
VSO 30	30	74	-	4.5	12.6	12.5	17
VSO 33	33	46	-	4.5	12.5	14	7.3
VSO 36	36	75	41	5.3	16.4	9.2	16.36



Specify the part number e.g.: **VSO 30 SI**
Please refer to the characteristics table above

The values represent the average characteristics of our products.
Note: All dimensions are in mm

VSBO, VSBO+, VSBO LM/BM

Bottle Suction Cups - Product Selection Guide



40 x 95 mm Bottle Suction Cups

p. 3/19



VSBO 4095 C NBR D5 X 30

TYPE	MATERIAL	REINFORCEMENTS	MOUNTING DISTANCE
Version VSBO -	NBR Nitrile	D5 <ul style="list-style-type: none"> 1 upper insert: stainless steel 4 reinforcements: stainless steel wire 1 lower reinforcement: stainless steel 	30 30 mm
Version VSBO+ C	NR Natural rubber	D6 <ul style="list-style-type: none"> 1 upper insert: stainless steel 4 reinforcements: stainless steel plates 1 lower reinforcement: stainless steel 	45 45 mm
		D5P <ul style="list-style-type: none"> 1 upper insert: stainless steel 4 reinforcements: stainless steel wire 1 lower reinforcement: polypropylene 	-
		D6P <ul style="list-style-type: none"> 1 upper insert: stainless steel 4 reinforcements: stainless steel plates 1 lower reinforcement: polypropylene 	30 and 45 mm (only available for VSBO+, cutout to be made on suction cup)

Note: 40 mm mounting hole distance available upon request

40 x 95 mm Bottle Suction Cups with Sensing Valve

p. 3/21



VSBO 4095 C NBR D5 CH4 30

TYPE	MATERIAL	REINFORCEMENTS	VALVE TECHNOLOGY	MOUNTING DISTANCE
Version VSBO -	NBR Nitrile	D5P <ul style="list-style-type: none"> 1 upper insert 3 reinforcements: stainless steel wire 1 lower reinforcement: polypropylene 	CH2 V2 mechanical sensing valve (only with D6P reinforcements)	30 30 mm
Version VSBO+ C	NR Natural rubber	D6P <ul style="list-style-type: none"> 1 upper insert 3 reinforcements: stainless steel plates 1 lower reinforcement: polypropylene 	CH4 V4 mechanical sensing valve	45 45 mm

Note: Version CHV_, including valve with calibrated leakage, available upon request.

Note: 40 mm mounting hole distance available upon request

Bottle Suction Cups with Gripping Interface

p. 3/24



VSBO 50105 NBR D5 X 45 BM10N

REINFORCEMENTS	INTERFACE
<ul style="list-style-type: none"> 1 upper insert: stainless steel 4 reinforcements: stainless steel wire 1 lower reinforcement: stainless steel 	BM10N POM support with 10 mm thick EPDM foam strip
<ul style="list-style-type: none"> 1 upper insert: stainless steel 4 reinforcements: stainless steel plates 1 lower reinforcement: stainless steel 	LMNBR Nitrile Magnum lip 50 x 105 mm

VSBO, VSBO+

40 x 95 mm Bottle Suction Cups



Industry-specific applications



Types of use



COVAL has designed a complete range of 4.5 bellows suction cups, including internal reinforcements and a 40 x 95 mm gripping lip, to meet application requirements for handling 75 cl bottles from the side during vertical or horizontal gripping. To increase the lifting force while maintaining a long travel distance and great flexibility, **VSBO** and **VSBO+** suction cups include a stainless steel upper insert, four stainless steel reinforcements inside the bellows, and a lower reinforcement, available either in stainless steel or polypropylene.

VSBO+ suction cups feature anti-slip cleats on the lip to ensure that 75 cl bottles can be handled at high rates and in humid environments.

■ **Dual mounting option:** To provide users with more options, the bottle suction cups feature M6 threads, so that they can be mounted from the inside using with two M5 screws or from the top using two M6 screws.

Note: To handle magnum bottles or textured bottles, COVAL has designed a range of suction cups with various gripping interfaces (see VSBO LM/BM).

Materials

Suction cups

NBR Nitrile
NR Natural rubber



VSBO



VSBO+



Suction Cup Characteristics

	Volume (cm ³)	Force (N) (1)	Force (N) (1)	f (2) (mm)	Weight (g)
VSBO 4095 (VSBO)	112.5	158	83	34	120
VSBO 4095C (VSBO+)	112.5	158	83	35.5	120

(1) Force measured at 65% on dry and smooth bottles without safety factor.

(2) f = Suction cup deflection.

Insert and Reinforcements

Version D5

- (a) 1 upper insert: stainless steel
- (b) 4 reinforcements: stainless steel wire
- (c) 1 lower reinforcement: stainless steel

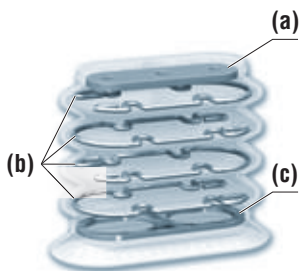

Version D5P

- (a) 1 upper insert: stainless steel
- (b) 4 reinforcements: stainless steel wire
- (c) 1 lower reinforcement: polypropylene

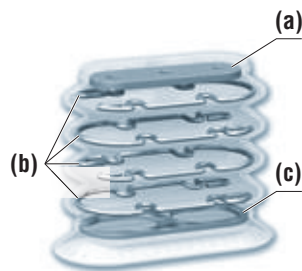

Version D6

- (a) 1 upper insert: stainless steel
- (b) 4 reinforcements: stainless steel plate
- (c) 1 lower reinforcement: stainless steel

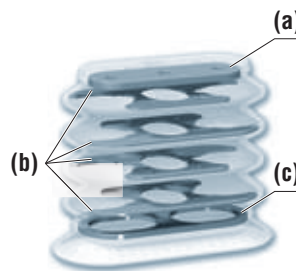

Version D6P

- (a) 1 upper insert: stainless steel
- (b) 4 reinforcements: stainless steel plate
- (c) 1 lower reinforcement: polypropylene

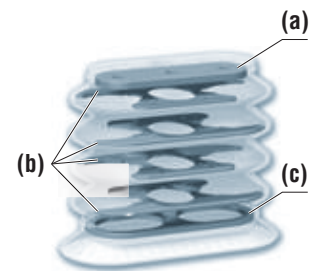

Mounting Hole Distance

VSBO and VSBO+ suction cups offer a choice of two mounting hole distances: 30 or 45 mm.

VSBO+ suction cups come in a version where the mounting holes have not been perforated, allowing users to choose during installation either a 30 mm or a 45 mm distance between mounting holes.

VSBO+ suction cups include integrated seals for easier mounting.

Available upon request: Vacuum switch connector

The VSBO and VSBO+ suction cups have a Ø 5 mm connector for a vacuum switch or blow-off valve. This option is only available for suction cups with a distance of 45 mm between mounting holes.

Integrated seals on VSBO+ suction cups

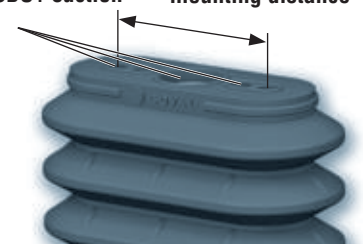

VSBO, VSBO+

40 x 95 mm Bottle Suction Cups



How To Order



VSBO 4095 C NBR D5 X 30

TYPE	MATERIAL	REINFORCEMENTS	MOUNTING DISTANCE
Version VSBO -	NBR Nitrile	<ul style="list-style-type: none"> 1 upper insert: stainless steel 4 reinforcements: stainless steel wire 	30 30 mm
Version VSBO+ C	NR Natural rubber	<ul style="list-style-type: none"> 1 lower reinforcement: stainless steel 	45 45 mm
		<ul style="list-style-type: none"> 1 upper insert: stainless steel 4 reinforcements: stainless steel plates 	- 30 and 45 mm (only available for VSBO+, cutout to be made on suction cup)
		<ul style="list-style-type: none"> 1 lower reinforcement: stainless steel 	
		<ul style="list-style-type: none"> 1 upper insert: stainless steel 4 reinforcements: stainless steel wire 	
		<ul style="list-style-type: none"> 1 lower reinforcement: polypropylene 	
		<ul style="list-style-type: none"> 1 upper insert: stainless steel 4 reinforcements: stainless steel plates 	
		<ul style="list-style-type: none"> 1 lower reinforcement: polypropylene 	

Note: 40 mm mounting hole distance available upon request

Suction Cup Dimensions

VSBO (VSBO4095)

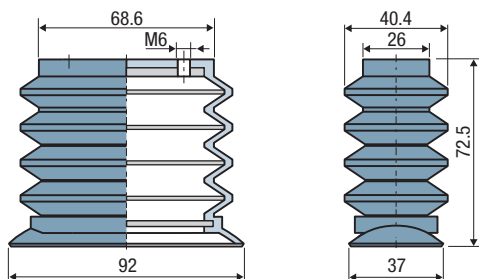

VSBO+ (VSBO4095C)

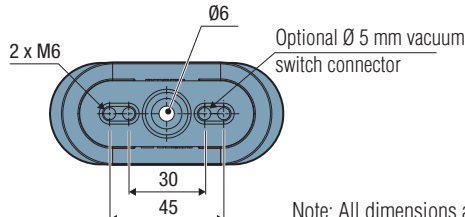
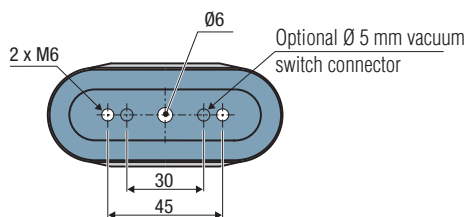
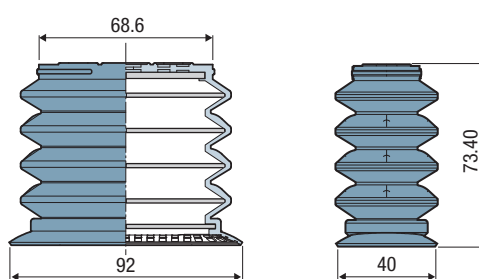

Note: All dimensions are in mm.

Replacement suction cups without insert or reinforcement



VSBO R 4095 C NBR N6 X 30

TYPE	MATERIAL	MOUNTING DISTANCE
Version VSBO -	NBR Nitrile	30 30 mm
Version VSBO+ C	NR Natural rubber	45 45 mm
		- 30 and 45 mm (only available for VSBO+, cutout to be made on suction cup)

VSBO, VSBO+

40 x 95 mm Bottle Suction Cups with Sensing Valve



Industry-specific applications



Types of use



VSBO_CH2_



VSBO_CH4_

COVAL has designed a complete range of 4.5 bellows suction cups, featuring a sensing valve, internal reinforcements, a 40 x 95 mm gripping lip to handle 750 ml bottles, as well as the ability to limit vacuum leakage from the network should a bottle be missing.

VSBO and **VSBO+** suction cups are made for handling bottles from the side during vertical or horizontal gripping.

VSBO+ suction cups feature anti-slip cleats on the lip to ensure that 750 ml bottles can be handled at high rates and in humid environments.

VSBO and VSBO+ suction cup technology features two different mechanical sensing valves that isolate the suction cups should a bottle be missing.





To increase the lifting force while maintaining a long travel distance and great flexibility for packing/unpacking applications, VSBO and VSBO+ suction cups feature an upper insert, three reinforcements inside the bellows, and a lower reinforcement or a trigger plate.

Materials

Suction cups

NBR Nitrile
NR Natural rubber

Suction Cup Characteristics

	 (cm ³)	 (N) ⁽¹⁾	 (N) ⁽¹⁾	 ⁽²⁾ (mm)	 (g)
VSBO / VSBO+_CH2	112.5	158	83	34	125
VSBO / VSBO+_CH4	112.5	158	83	22	125

(1) Force measured at 65% on dry and smooth bottles without safety factor.

(2) f = Suction cup deflection.

Sensing Valve Technologies

CH2 mechanical sensing valve

The **CH2 sensing valve** opens as pressure is exerted on the suction cup by an **internal** reinforcement, called a “**trigger plate**”.

The CH2 sensing valve is only compatible with stainless steel reinforcement plates (version D6P).

Sensing valve
CH2

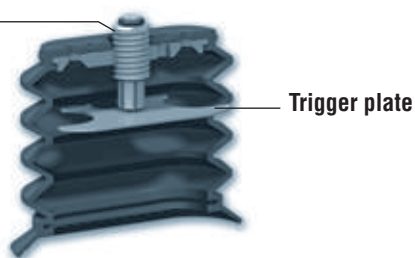

Trigger plate

Advantages:

- Suction cup travel is not lost when suction cup is evacuated
- Adjustable valve
- Robust mechanical design

Materials:

- Upper insert: aluminum
- Valve body: aluminum
- O-ring: nitrile
- Spring: stainless steel
- Trigger plate: stainless steel

CH4 mechanical sensing valve

The **CH4 sensing valve** opens as soon as pressure is exerted on the suction cup by a **lower** reinforcement called “**trigger plate**”.

The CH4 sensing valve is compatible with stainless steel reinforcement wire or plates (versions D5P and D6P).

Sensing valve
CH4

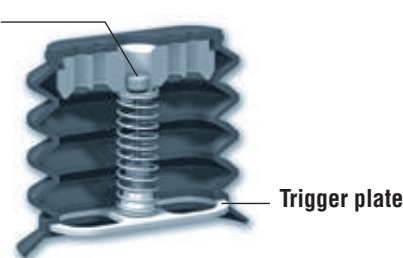

Trigger plate

Advantages:

- Valve is adjusted from underneath the suction cup
- Suction cup is evacuated immediately as soon as pressure is applied

Materials:

- Upper insert: POM
- Pin: nylon
- Cone: aluminum
- O-ring: nitrile
- Spring: stainless steel
- Trigger plate: HDPE

Sensing valve with calibrated leakage (CHV_)

COVAL has designed sensing valve solutions with calibrated leakage. Leakage calibration depends on the application and requires an engineering study (available upon request).

3 VSBO, VSBO+

VSBO, VSBO+

40 x 95 mm Bottle Suction Cups with Sensing Valve



Insert and Reinforcements

Version D5P

- (a) 3 reinforcements: stainless steel wire
- (b) 1 lower reinforcement: polypropylene

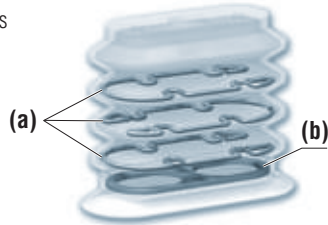

Version D6P

- (a) 3 reinforcements: stainless steel plate
- (b) 1 lower reinforcement: polypropylene

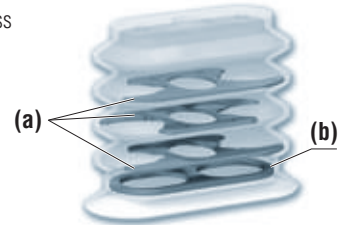

Mounting Hole Distance

VSBO and VSBO+ suction cups offer a choice of two mounting hole distances: 30 or 45 mm.
VSBO+ suction cups include integrated seals for easier mounting.

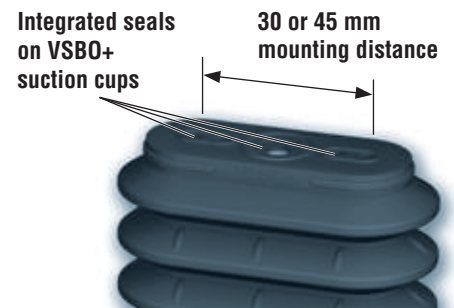

Available upon request: Vacuum switch connector

The VSBO and VSBO+ suction cups with sensing valve have a $\varnothing 5$ mm connector for a vacuum switch or blow-off valve. This option is only compatible with suction cups with a 45 mm distance between mounting holes.

Suction Cup Dimensions

CH2 sensing valve

VSBO
(VSBO4095_D6PCH2_)

VSBO+
(VSBO4095C_D6PCH2_)

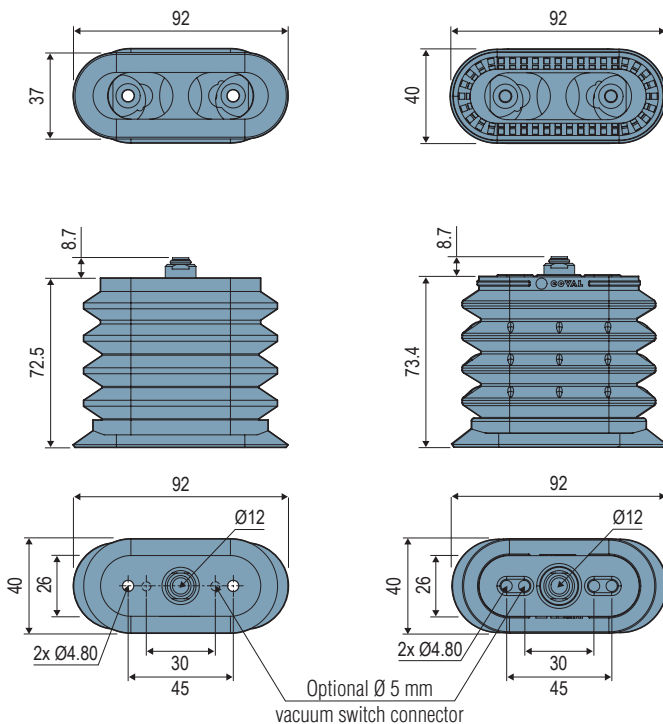

CH4 sensing valve

VSBO
(VSBO4095_D_PCH4_)

VSBO+
(VSBO4095C_D_PCH4_)

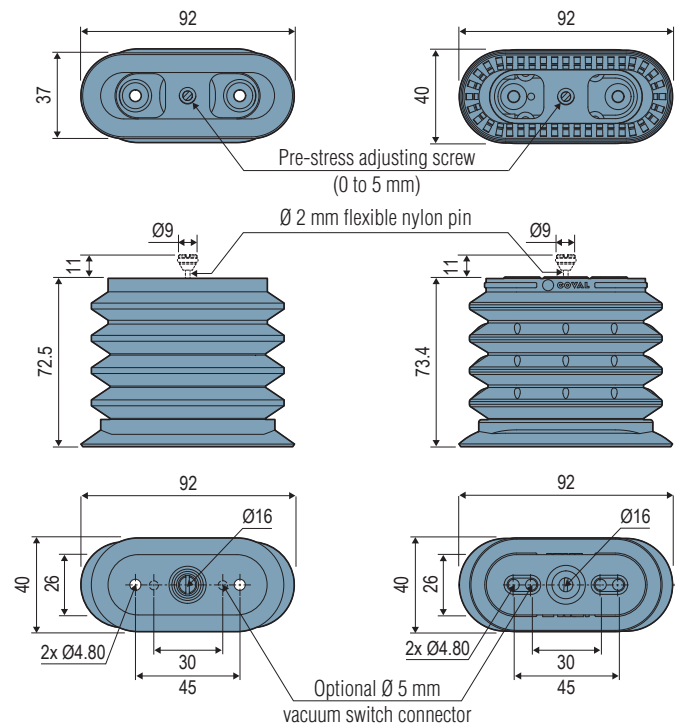

3
VSBO, VSBO+

VSBO, VSBO+

40 x 95 mm Bottle Suction Cups with Sensing Valve



Modular Bottle Suction Cups

VSBO__CH2

VSBO series suction cup VSBO+ series suction cups

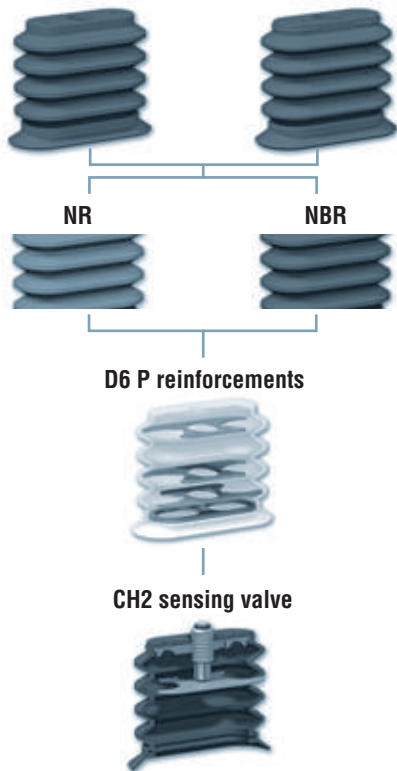

VSBO__CH4

VSBO series suction cup VSBO+ series suction cups

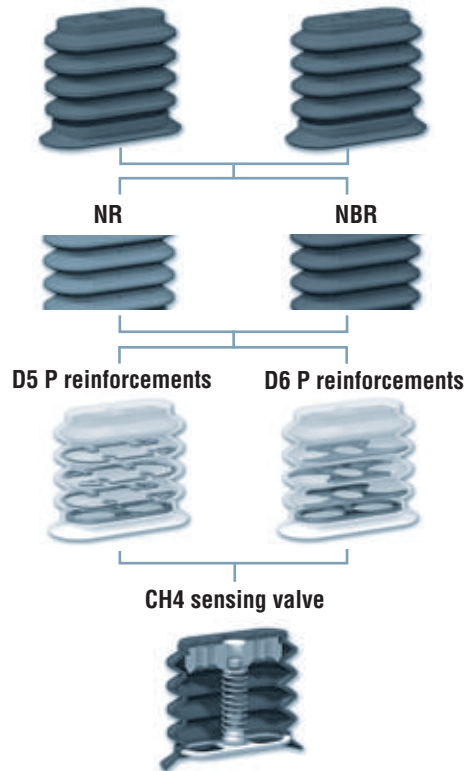

How To Order



VSBO 4095 C NBR D5 CH4 30

TYPE		MATERIAL	REINFORCEMENTS	VALVE TECHNOLOGY	MOUNTING DISTANCE	
Version VSBO	-				NBR NR	D5P <ul style="list-style-type: none"> 1 upper insert 3 reinforcements: stainless steel wire 1 lower reinforcement: polypropylene D6P <ul style="list-style-type: none"> 1 upper insert 3 reinforcements: stainless steel plates 1 lower reinforcement: polypropylene
Version VSBO+	C	45	45 mm			

Note: 40 mm mounting hole distance available upon request

Replacement suction cups without insert or reinforcement



VSBO R 4095 C NBR N16 X 30

TYPE		MATERIAL	Ø OF VACUUM FLOW	MOUNTING DISTANCE	
Version VSBO	-			NBR NR	N12 12mm Ø of vacuum flow for mounting with mechanical sensing valve V2 (CH2) N16 16mm Ø of vacuum flow for mounting with mechanical sensing valve V4 (CH4)
Version VSBO+	C	45	45 mm		

VSBO LM/BM

Bottle Suction Cups with Gripping Interface

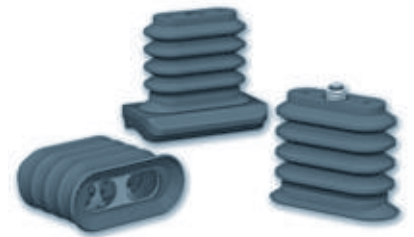

Industry-specific applications



Types of use



To meet the requirements for handling magnum bottles and textured bottles, COVAL has designed a range of 4.5 bellows suction cups, including internal reinforcements and a choice of two gripping interfaces.

- A magnum bottle interface featuring a lip shape and surface suited for the weight and diameter of magnum bottles
- A foam strip interface featuring a support shape and foam strip that compensates for any irregular surfaces on specific types of bottles (e.g. textured or faceted surface, coat of arms, etc.)

To increase the lifting force while maintaining a long travel distance and great flexibility for packing/unpacking applications, VSBO LM/BM suction cups are feature an upper insert, three reinforcements inside the bellows, and a lower reinforcement to fit the desired interface.

The **VSBO LM/BM** series suction cups are designed for handling bottles from the side.

- Version VSBO LM: vertical or horizontal gripping
- Version VSBO BM: horizontal gripping

Materials

Suction cups





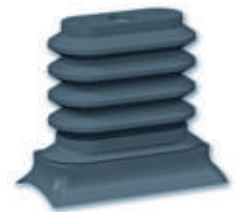
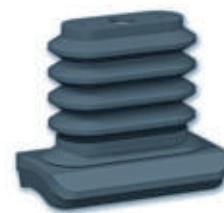

NBR Nitrile

VSBO50105NBR_BM10N



VSBO50105NBR_LMNBR

Suction Cup Characteristics

	 (cm ³)	 (N) ⁽¹⁾	 (N) ⁽¹⁾	 f ⁽²⁾ (mm)	 (g)
VSBO50105NBR_BM10N	150	230	70	7 + 34	205
VSBO50105NBR_LMNBR	142.5	245	83	2.5 + 34	205

(1) Force measured at 65% on dry and smooth bottles without safety factor.

(2) f = Suction cup deflection.

Bottle Suction Cups with Gripping Interface

For textured bottles

Part no.: VSBO50105NBR_BM10N

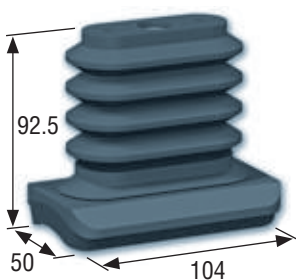

The **VSBO50105_BM10N** suction cup is designed for handling textured bottles. It features a curved gripping interface that fits the shape of the bottle and includes an EPDM foam seal that compensates for any irregular surfaces and guarantees an airtight seal.

For Magnum bottles

Part no.: VSBO50105NBR_LMNBR

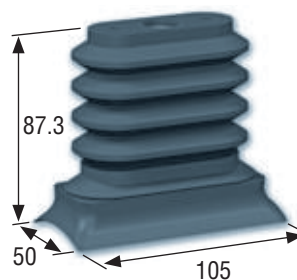

The **VSBO50105_LMNBR** suction cup is designed for handling magnum bottles. It features a lip shape and surface suited for the weight and diameter of magnum bottles.

The suction cup includes the following:

- One stainless steel upper insert
- One nitrile suction cup with 4 bellows, VSBO4095NBR
- Four stainless steel internal reinforcements
- One stainless steel lower reinforcement
- One gripping interface with 10 mm EPDM foam seal

The suction cup includes the following:

- One stainless steel upper insert
- One nitrile suction cup with 4 bellows, VSBO4095NBR
- Four stainless steel internal reinforcements
- One stainless steel lower reinforcement
- One 50 x 105 mm Magnum nitrile lip

VSBO LM/BM

Bottle Suction Cups with Gripping Interface

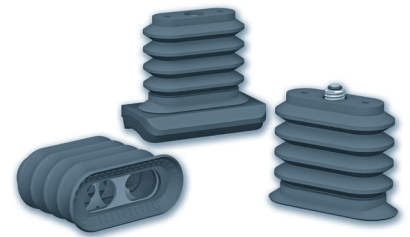

Reinforcements

Version D5

- (a) 1 upper insert: stainless steel
- (b) 4 reinforcements: stainless steel wire
- (c) 1 lower reinforcement: stainless steel

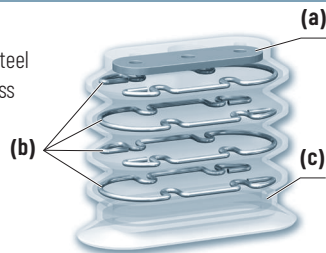

Version D6

- (a) 1 upper insert: stainless steel
- (b) 4 reinforcements: stainless steel plate
- (c) 1 lower reinforcement: stainless steel

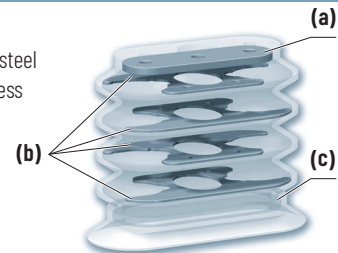

3

VSBO LM/BM

Bottle Suction Cups with Modular Gripping Interfaces

PART NUMBER FOR COMPLETE SUCTION CUPS

including gripping interface with foam seal:

- With stainless steel reinforcement wire (version D5):
Part no.: **VSBO50105NBRD5X45BM10N**
- With stainless steel reinforcement plate (version D6):
Part no.: **VSBO50105NBRD6X45BM10N**

Bottle suction cup
VSBO4095NBR



4 reinforcements:
stainless steel wire
D5

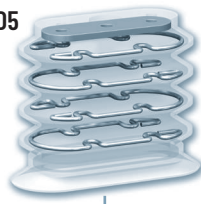

4 reinforcements:
stainless steel plate
D6

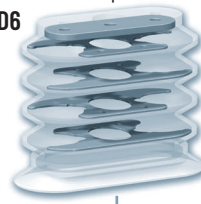

Gripping interface kit with
memory foam seal,
VSBOKIT50105BM10N

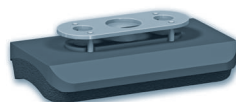

Magnum lip kit,
VSBOKIT50105LMNBR

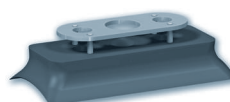

PART NUMBER FOR COMPLETE SUCTION CUPS

including gripping interface with
50 x 105 mm nitrile lip seal:

- With stainless steel reinforcement wire (version D5):
Part no.: **VSBO50105NBRD5X45LMNBR**
- With stainless steel reinforcement plate (version D6):
Part no.: **VSBO50105NBRD6X45LMNBR**

How To Order



VSBO 50105 NBR D5 X 45 BM10N

REINFORCEMENTS		INTERFACE
<ul style="list-style-type: none"> ■ 1 upper insert: stainless steel ■ 4 reinforcements: stainless steel wire ■ 1 lower reinforcement: stainless steel 	D5	<p>BM10N POM support with 10 mm thick EPDM foam strip</p>
<ul style="list-style-type: none"> ■ 1 upper insert: stainless steel ■ 4 reinforcements: stainless steel plates ■ 1 lower reinforcement: stainless steel 	D6	<p>LMNBR Nitrile Magnum lip 50 x 105 mm</p>

Available upon request: Vacuum switch connector

VSBO LM/BM suction cups feature an optional Ø 5 mm connector for a vacuum switch or blow-off valve.

VSBO LM/BM

Bottle Suction Cups with Gripping Interface



Suction Cup Dimensions

VSBO50105NBR_X45BM10N

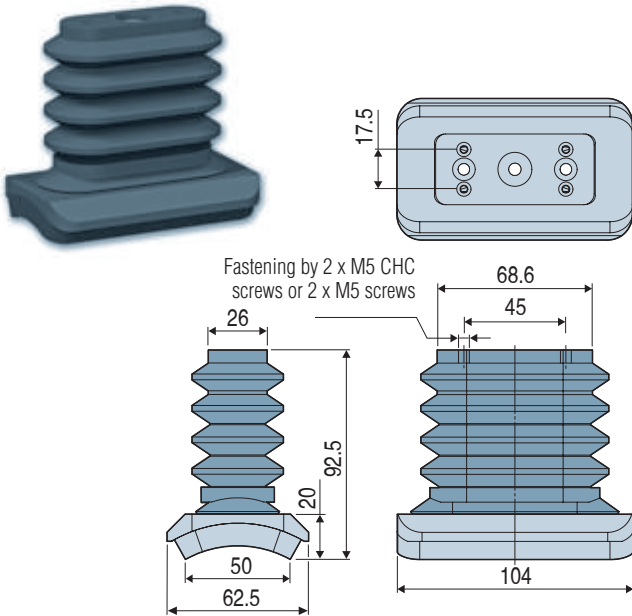

VSBO50105NBR_X45LMNBR

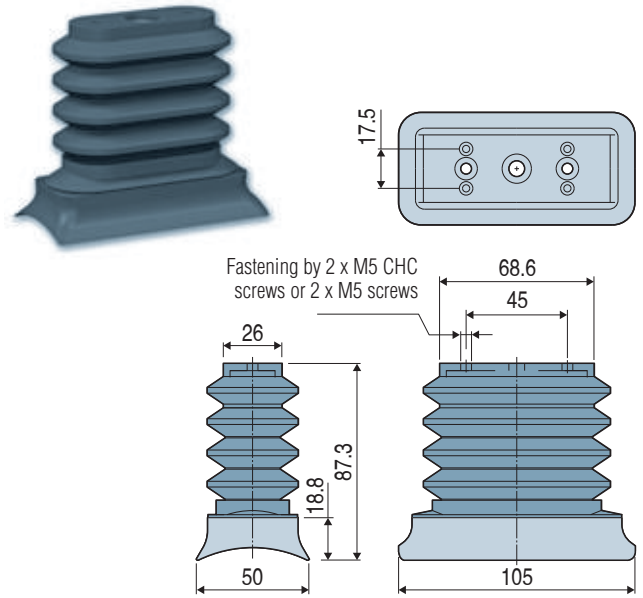

Gripping Interface Kits

Gripping interface kits are used to turn 40 x 95 mm bottle suction cups (part no. VSBO4095NBR) into magnum bottle suction cups or suction cups with a foam gripping interface.

The kits include the reinforcement to fit the interface under the suction cup.

- Gripping interface kit with memory foam seal, 10 mm thick:
Part no.: **VSBOKIT50105BM10N**
- Nitrile Magnum lip kit 50 x 105 mm
Part no.: **VSBOKIT50105LMNBR**

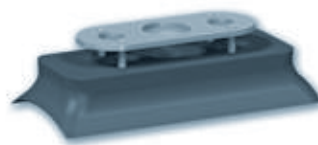
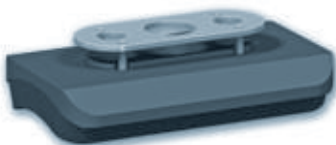

Part Numbers for Spare Parts

- Nitrile suction cup with 4.5 bellows (without insert or reinforcement):
Part no.: **VSBOR4095NBRN6X45**
- POM curved gripping interface with memory foam seal, 10 mm th.
Part no.: **VSBOR50105BM10N**
- 50 x 105 mm nitrile lip:
Part no.: **VSBOR50105LMNBR**

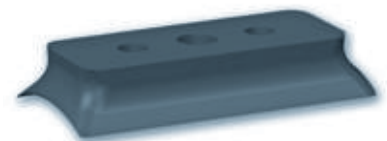
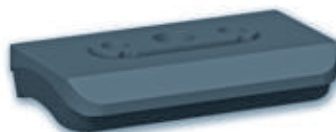

VBO

Suction Cup for Bottle Handling via the Punt



Industry-specific application



Types of use



Developed in partnership with manufacturers in the wine sector, the VBO suction cup system is designed for gripping bottles by the punt on disgorging stations.

Its modular design allows for a high degree of flexibility in positioning the whole assembly when gripping the base, as well as excellent sealing when gripping different types of bottles

The VBO suction cup system consists of:

- A 2.5 bellows suction cup, Ø62 mm in Nitrile with 31mm stroke, ensuring a high degree of flexibility in positioning on the bottle base (swivel effect, deflection).
- An aluminium fitting threaded G1/4" -Male allowing the assembly to be mounted on the tool.
- Aluminium top and bottom coupler plates for joining the suction cup to the gripping disc.
- A silicone gripping disc (COVAL-Flex) ensures the tightness of the grip on various punts.

Materials

Suction Cup: NBR - Nitrile

Fitting and Couplers: Aluminum

Gripping Disc: SI - Silicone

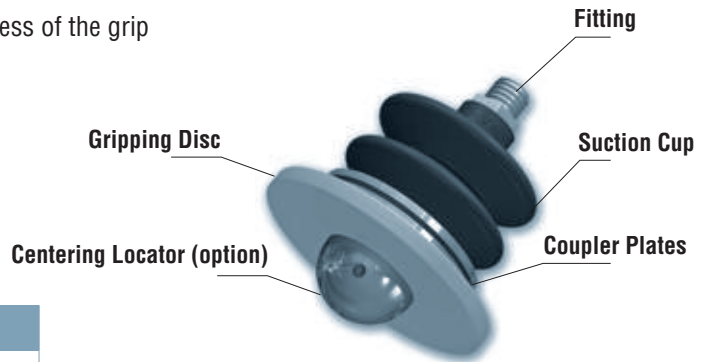

Suction Cup Characteristics

	Ø (mm)	Volume (cm ³)	Force (N) ⁽¹⁾
VBO60D85A2.5X62NBRM14C0	85	72.5	-

Force to be determined depending on application

Suction Cup Dimensions

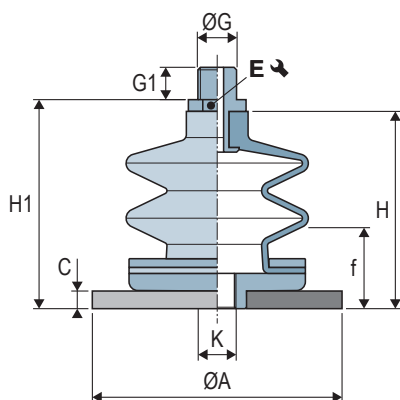

	Ø A	C	f ⁽²⁾	H	H1	Ø G	G1	E ↘	K	Weight (g)
VBO60D85A2.5X62NBRM14C0	85	6	31	65	69	G1/4"-M	11	Hexa 17	M14-F	130

(2) f = Deflection of the suction cup.



Please specify part n°
VBO60D85A2.5X62NBRM14C0
See table of properties above.

The values represent the average characteristics of our products.
Note: All dimensions are in mm.

VPBO

Coupler Plates for gripping bottles by the Punt



The VPBO Coupler Plates are designed for gripping bottles by the Punt on disgorging stations.

3 diameters available:

- Ø 65 mm for 1/2 bottles
- Ø 75 mm for 75 cl bottles
- Ø 95 mm for Magnum

Materials

NR Natural rubber 45 Shore A

Industry-specific applications



Types of use





3
VPBO

Characteristics

	Ø (mm)
VPB065NR	65
VPB075NR	75
VPB095NR	95

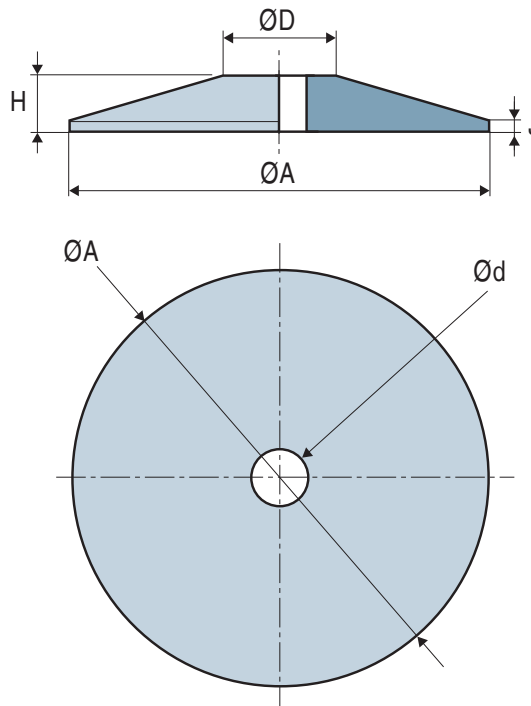
Dimensions



	Ø A	H	Ø d	Ø D	J	 (g)
VPB065NR	65	10	10	23	2	19
VPB075NR	75	10	10	20	2	24
VPB095NR	95	10	10	49	2	47

 Specify the part number e.g.: VPB095NR
Please refer to the characteristics table above

The values represent the average characteristics of our products.
Note: All dimensions are in mm.

VPA

Suction Cups for Paper Applications



Industry-specific applications



Types of use





The VPA series is a range of suction cups with a very flexible lip used to handle highly flexible materials. These suction cups are specially designed for gripping in applications such as label placement, plastic films and printing. They are mainly produced in natural rubber (NR) to provide resistance to abrasion caused by paper and cardboard or in silicone (SIT5) for food compatibility (FDA and CE 1935/2004).

Materials

NBR	Nitrile	NR	Natural rubber
SIT5	Translucent silicone	STN	SITON®

Suction Cup Characteristics

	Ø (mm)	 (N) ⁽¹⁾	NBR	SIT5	NR	STN
VPA 15	15	2.9	-	VPA15SIT5	VPA15NR	-
VPA 20	20	4.3	-	VPA20SIT5	VPA20NR	-
VPA 25	25	6.5	-	VPA25SIT5	VPA25NR	-
VPA 26	26	6.5	-	-	VPA26NR	VPA26STN
VPA 30	30	9.4	VPA30NBR	VPA30SIT5	VPA30NR	VPA30STN
VPA 35 A	35	12.3	-	-	VPA35NR	-
VPA 40	40	20.9	-	VPA40SIT5	VPA40NR	-
VPA 25000	25.5	7.2	-	VPA25000SIT5	VPA25000NR	-
VPA 25001	25.5	7.2	-	VPA25001SIT5	VPA25001NR	-

(1) Actual force of the suction cup with 65% vacuum and a safety factor of 2 included.

VPA 15...40

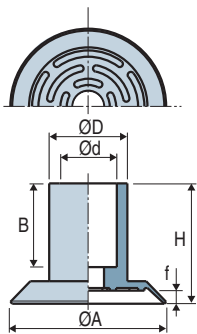

VPA 25000

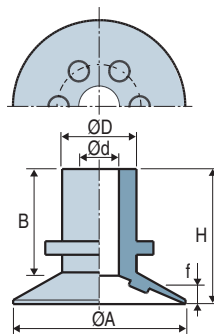

VPA 25001

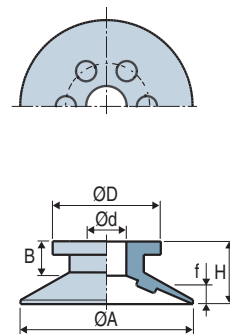

Suction Cup Dimensions

	ØA	H	Ød	ØD	f ⁽²⁾	B
VPA 15	15	9.8	5	9	0.8	7
VPA 20	20	10.3	5	10	1.3	7
VPA 25	25	10.8	5	10	1.8	7
VPA 26	26	21.5	6	14	1.9	13.5
VPA 30	30	23	11	15	2.5	16
VPA 35 A	35	23	11	15	2.5	16
VPA 40	40	20	8	16	2	15
VPA 25000	25.5	20	5.8	11	3	15.8
VPA 25001	25.5	9.5	5.8	16	3	5.1

(2) f = Deflection of the suction cup.

The values represent the average characteristics of our products.
Note: All dimensions are in mm

Accessories

To optimize the use of your suction cups, Coval offers a comprehensive range of accessories (nozzle fittings, spring extensions, and feeder systems, etc.), see chapters 4 and 14.



Specify the part number e.g.: VPA20NR
Please refer to the characteristics table above



Choice of Fittings

	Male fittings				Female fittings	
	G1/8"-M	G1/4"-M	M5-M	M6-M	G1/8"-F	G1/4"-F
VPA 15	IM11A	-	IM21	IM22	IF10A	-
VPA 20	IM11A	-	IM21	IM22	IF10A	-
VPA 25	IM11A	-	IM21	IM22	IF10A	-
VPA 26	-	-	-	-	-	-
VPA 30	-	IM51SP143	IM5VPA30	-	-	IF50SP143
VPA 35 A	-	IM51SP143	IM5VPA30	-	-	IF50SP143
VPA 40	-	IM41SP477	-	-	-	IF40SP477
VPA 25000	-	-	-	-	-	-
VPA 25001	IM11ASP082	-	-	-	IF10ASP082	-

Male fittings
VPA 15...25

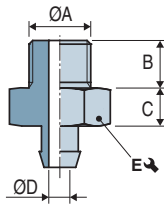

Female fittings
VPA 15...25

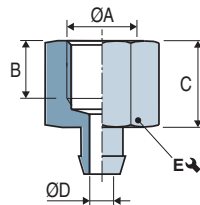

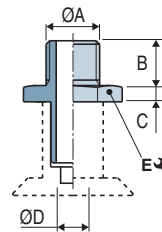

Male fittings
VPA 30...40

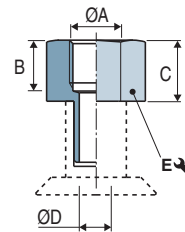

Female fittings
VPA 30...40



Barbed Fittings

Model	ØA	B	C	ØD	E 	Materials	 (g)
IM 11 A	G1/8"-M	7.5	6	3.5	14	Aluminum	4.1
IM 11 A SP082	G1/8"-M	7.5	6	3.5	14	Aluminum	4.1
IM 21 ⁽¹⁾	M5-M	4.5	5	2.5	7	Nickel-plated brass	3.1
IM 22 ⁽¹⁾	M6-M	5	5	3.5	7	Nickel-plated brass	2.7
IM 41 SP477	G1/4"-M	11	4	4.4	17	Aluminum	7.5
IM 51 SP143	G1/4"-M	11	6	8	21	Aluminum	10.5
IM 5 VPA30	M5-M	5	3	2.5	13	Aluminum	5.7
IF 10 A	G1/8"-F	8	12	3.5	14	Aluminum	4
IF 10 A SP082	G1/8"-F	8	12	3.5	14	Aluminum	4
IF 50 SP143	G1/4"-F	10	15	8	21	Aluminum	14.4
IF 40 SP477	G1/4"-F	10	15	4.4	17	Aluminum	8

(1) Flow control nozzle available: orifice calibrated to reduce the leakage in case of use of a multi-cup gripper (refer to page 4/10)

VPAL

Suction Cups for Labels

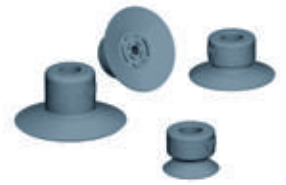

Thanks to their extra-flat shape and great lip flexibility, the VPAL suction cups are especially adapted for gripping and handling IML labels or flexible materials. They are made of silicone to meet food compatibility standards (FDA and CE 1935/2004).

Industry-specific applications





Types of use



Materials

SIBL5 Blue Silicone 50 Shore

Suction Cup Characteristics

	Ø (mm)	 (N) ⁽¹⁾	SIBL5
VPAL 10	10	1.5	VPAL10SIBL5
VPAL 15	15.5	2.1	VPAL15SIBL5
VPAL 20	20	4.4	VPAL20SIBL5

(1) Actual force of the suction cup with 65% vacuum and a safety factor of 2 included.

Suction Cup Dimensions

	ØA	H	Ød	ØD	f ⁽²⁾	B
VPAL 10	10	7.5	4	8.5	1.5	4
VPAL 15	15.5	7.5	4	8.5	1.5	4
VPAL 20	20	9.9	4	9	1.4	4

(2) f = Deflection of the suction cup.

VPAL10

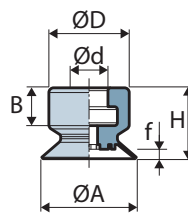

VPAL15

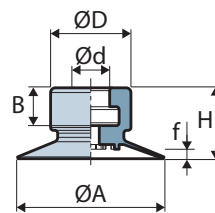
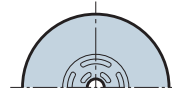

VPAL20

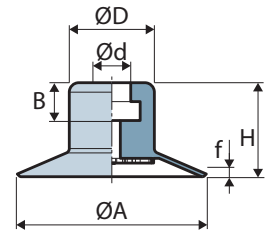
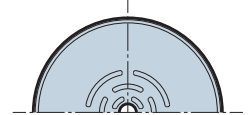

Choice of Fittings

	Male fittings		Female fittings	
	G1/8"-M	M5-M	G1/8"-F	M5-F
VPAL 10	IM18VPG5	IM5VPG5	IF18VPG5	IF5VPG5
VPAL 15	IM18VPG5	IM5VPG5	IF18VPG5	IF5VPG5
VPAL 20	IM18VPG5	IM5VPG5	IF18VPG5	IF5VPG5

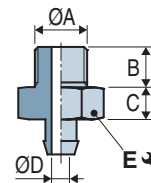

Male fittings
VPAL 10...20

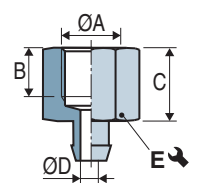

Female fittings
VPAL 10...20



Barbed Fittings

Model	ØA	B	C	ØD	E 	Materials	 (g)
IM 5 VPG 5	M5-M	4.5	3.5	2.2	7	Aluminum	0.7
IM 18 VPG 5	G1/8"-M	8	5	2.2	14	Aluminum	3.9
IF 5 VPG 5	M5-F	6	9	2.2	8	Aluminum	1.2
IF 18 VPG 5	G1/8"-M	9	15	2.2	14	Aluminum	5.1

The values represent the average characteristics of our products.
Note: All dimensions are in mm

Accessories

To optimize the use of your suction cups, Coval offers a comprehensive range of accessories (nozzle fittings, spring extensions, and feeder systems, etc.), see chapters 4 and 14.



Specify the part number e.g.: **VPAL15SIBL5**
Please refer to the characteristics table above

VSAPL

Suction Cups with 1.5 Bellows for Labels



The 1.5 bellows VSAPL suction cup is especially adapted for gripping and handling IML labels or flexible materials.

They are made of silicone to meet food compatibility standards (FDA and CE 1935/2004).

Materials

SIBL5 Blue Silicone 50 Shore A



Industry-specific applications



Types of use



Suction Cup Characteristics

	Ø (mm)	 (N) ⁽¹⁾	 (g)	Fitting M5-M
VSAPL11SIBL5	11	1.5	0.7	IM5VPG5

(1) Actual force of the suction cup with 65% vacuum and a safety factor of 2 included.

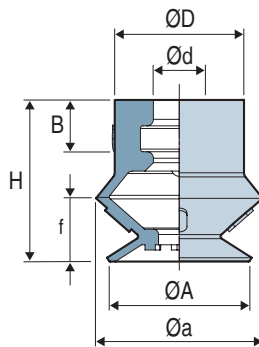



Suction Cup Dimensions

	ØA	H	Øa	Ød	ØD	f ⁽²⁾	B
VSAPL11SIBL5	11.2	12.5	12.9	4	10	5	4

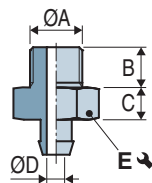
(2) f = Deflection of the suction cup.



Barbed Fittings

Model	ØA	B	C	ØD	E 	Materials	 (g)
IM 5 VPG 5	M5-M	4.5	3.5	2.2	7	Aluminum	0.7



Specify the part number e.g.: VSAPL11SIBL5
Please refer to the characteristics table above

The values represent the average characteristics of our products.
Note: All dimensions are in mm

VPR

Suction Cups for Mailing Applications



The COVAL range of mailing application suction cups is designed to meet the requirements of the mailing industry. The improved characteristics mean you can optimize production equipment in your branch, such as:

- Envelope stuffing
- Film wrapping
- Envelope insertion
- Mailing (picking).

Industry-specific applications

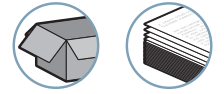

Types of use



3

Material

NR Natural rubber

Advantages

- Longer life expectancy
- Optimized for high throughput rates
- Excellent resistance to abrasion and slipping
- 100% compatible with machines currently on the market

Suction Cup Characteristics

	ØA	H	Ød	Ød1	ØD	B	Color	NR
VPR 001	24.4	15	5.9	7.8	13.8	8	green	VPR001NR
VPR 002	25.7	14.5	5.9	7.8	14	9	brown	VPR002NR
VPR 003	20	14.2	5.7	4	13.8	6	red	VPR003NR
VPR 004	20	14.2	5.7	5	14.8	6	black	VPR004NR

VPR 001 - 002

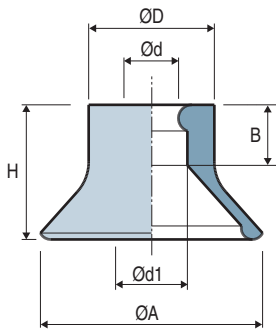

VPR 003 - 004

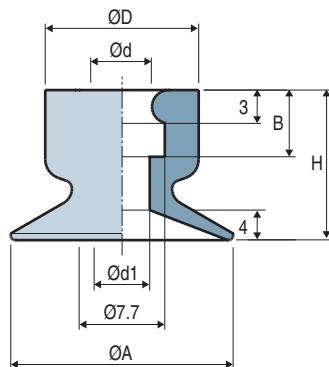

The values represent the average characteristics of our products.
Note: All dimensions are in mm



Specify the part number e.g.: VPR003NR
Please refer to the characteristics table above

VPAG

Rounded Suction Cups

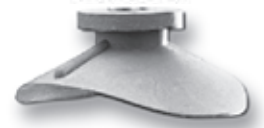

Thanks to very flexible lips, the VPAG range is suitable for gripping flexible materials such as labels or sheets of paper as well as textured objects. Their shape allows them to be used for unstacking.

Industry-specific applications

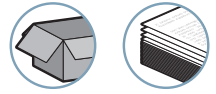

Types of use



Materials

NR Natural rubber

Suction Cup Characteristics

	NR	Fittings	
		G1/8"-M	G1/8"-F
VPAG 25	VPAG25NR	IM11ASP082	IF10ASP082
VPAG 3536	VPAG3536NR	-	-

Suction Cup Dimensions

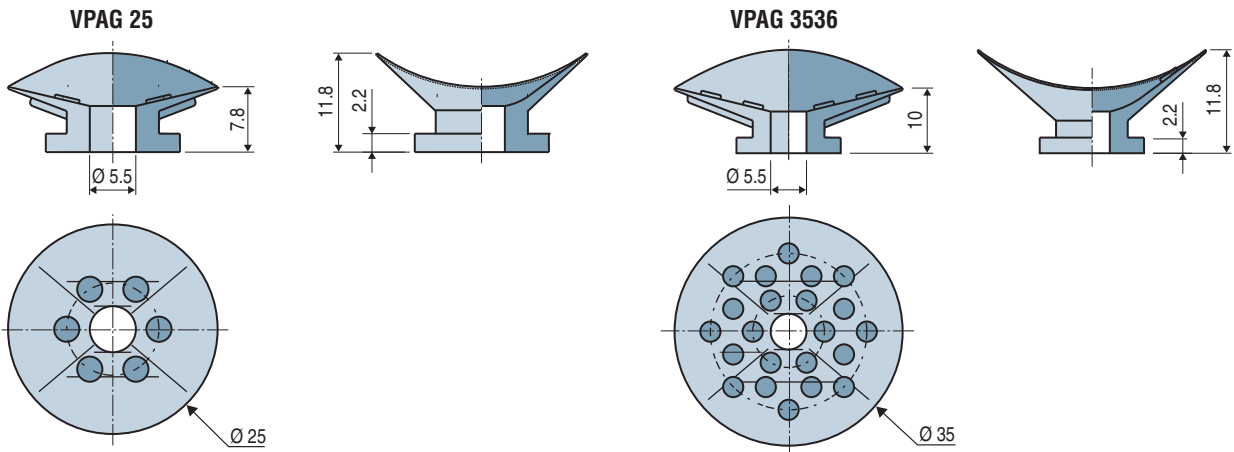

Barbed Fittings

Male - IM

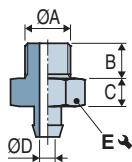

Female - IF

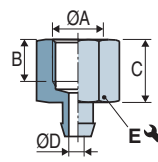

	ØA	B	C	ØD	E	Materials	g (g)
IM 11 A SP082	G1/8"-M	7.5	6	3.5	14	Aluminum	4.1
IF 10 A SP082	G1/8"-F	8	12	3.5	14	Aluminum	4.0

The values represent the average characteristics of our products.
Note: All dimensions are in mm



Specify the part number e.g.: VPAG3536NR
Please refer to the characteristics table above.

Accessories

To optimize the use of your suction cups, Coval offers a comprehensive range of accessories (nozzle fittings, spring extensions, and feeder systems, etc.), see chapters 4 and 14.

VPSC

Ultra-Flat, Non-Marking Suction Cups

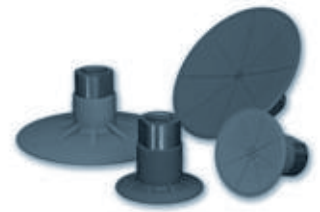

Industry-specific applications



Types of use



Developed through partnerships with the composite material industry, the VPSC suction cups are dedicated to the handling of raw composite. Their ultra-flat profile and innovative system of vacuum distribution across the surface of the cups provide optimized gripping with no mark and no deformation. The extra thin sealing lip contours to the product shape without restriction.

The specific characteristics of these suction cups enable its use in other fields such as cheese handling or other fragile, easily deformed products.

The VPSC cups are available in two materials to meet all the applications:

- Polyurethane (PU), high resistance to hydrocarbons and high durability.
- Silicone (SIBL5), food compliance. FDA and CE 1935/2004 standards.

The VPSC suction cups are equipped with a G1/4" female pressed aluminum fitting.

3



VPSC

Materials

PU Polyurethane 60 Shore A

SIBL5 Blue Silicone 50 Shore A

Suction Cup Characteristics



	Ø (mm)	Volume (cm ³)	Force (N) ⁽¹⁾	Force (N) ⁽¹⁾	PU	SIBL5
 VPSC 40	40	5.6	27	15	VPSC40PUIF14	VPSC40SIBL5IF14
 VPSC 80	80	11.2	92.6	46.3	VPSC80PUIF14	VPSC80SIBL5IF14

(1) Actual force of the suction cup in use with 65% vacuum and including a safety factor of 2 for horizontal handling and a factor of 4 for vertical handling.

When used on deformable materials, the indicated forces may require more consideration. Please contact us, particularly for composite applications.

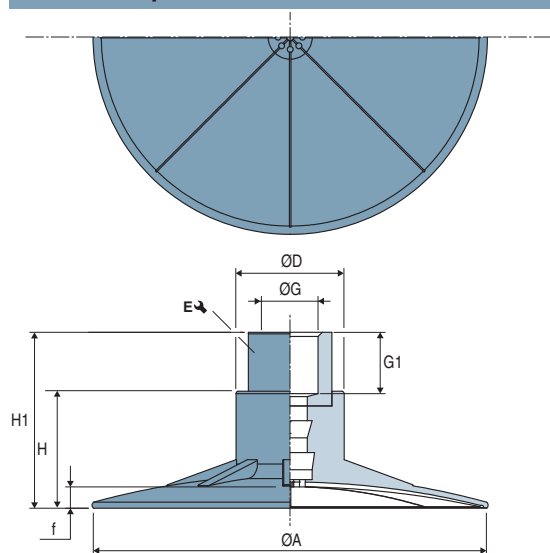
Suction Cup Dimensions



	Ø A	Ø D	f ⁽²⁾	H	H1	Ø G	E	Weight (g)
 VPSC 40	40	21	1.5	21.8	33.8	G1/4"-F	17	16
 VPSC 80	80	22	4	23.8	35.8	G1/4"-F	17	26

(2) f = Deflection of the suction cup.



Specify the part number e.g.: **VPSC80PUIF14**
Please refer to the characteristics table above

The values represent the average characteristics of our products.
Note: All dimensions are in mm

VPYR

Radial Ball-joint Suction Cups



VPYR series ball-joints are recommended for gripping rounded or rotating products. They are also recommended for gripping requiring high mechanical resistance and force.

Industry-specific applications

Materials

Suction cups

NBR Nitrile
SI Silicone

Ball-joint

Nickel-plated brass and zinc-plated steel

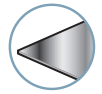

Types of use



Suction Cup Characteristics

	(N) ⁽¹⁾	R_{min}	$\varnothing A$	B	C	D	E	E1	f ⁽²⁾	NBR	SI	(g)
VPYR 50	65	41	50	60	12	42	19	-	4	VPYR50NBR	VPYR50SI	117
VPYR 60	93.7	70	60	93	16	58	21	19	5	VPYR60NBR	VPYR60SI	352
VPYR 80	166.1	100	80	95	18	60	21	19	6	VPYR80NBR	VPYR80SI	444
VPYR 100	260	150	100	95	18	60	21	19	6	VPYR100NBR	VPYR100SI	568

(1) Actual force of the suction cup with 65% vacuum and a safety factor of 2 included.

(2) f = Deflection of the suction cup.

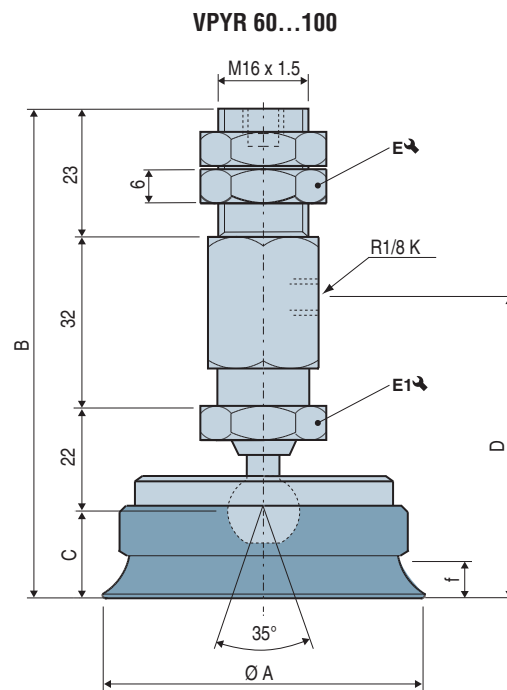
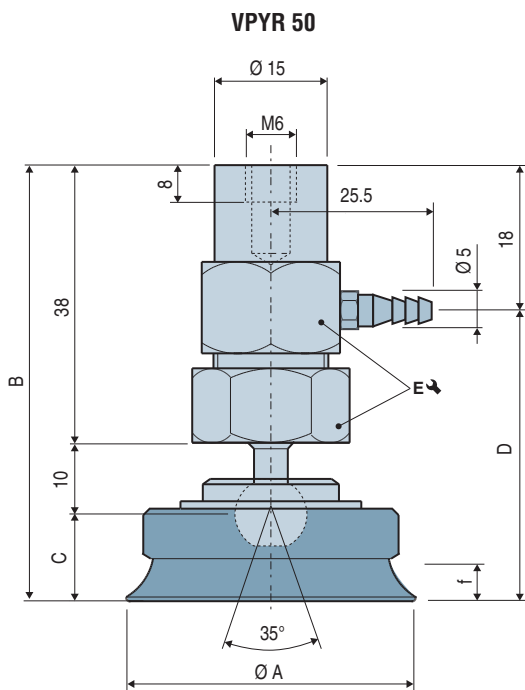

Replacement suction cup

If the suction cup becomes worn, the VPR suction cup can be ordered alone, specifying the diameter ($\varnothing A$) and material of the suction cup. Example VPR 50 NBR.

The values represent the average characteristics of our products.
Note: All dimensions are in mm



Specify the part number e.g.: VPYR50NBR
Please refer to the characteristics table above.

Accessories

Possibility of telescopic spring-mounting on request.

SPL

Heavy Load Suction Cups

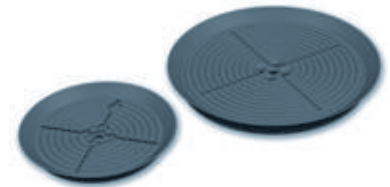

SPL suction cups are used to handle heavy loads such as sheet metal or glass panels. They have internal cleats allowing them to handle thin sheet metal without distorting them and for vertical handling (non-slip).

SPL suction cups are delivered without holes for fittings or you can choose from our range of standard models or specific models on request.

Industry-specific applications

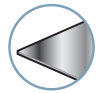

Types of use



Materials

NBR Nitrile
SI Silicone

3

SPL

Suction Cup Characteristics

	Volume (cm ³)	Force (N) (1)	Force (N) (1)	Ø A	H	Ø D	f (2)	NBR	SI	Fittings (3)	Weight (kg)
SPL 240	510	1300	650	240	28	200	14	SPL240NBR	SPL240SI	Steel	2.2
SPL 340	720	2744	1372	340	32	300	15	SPL340NBR	SPL340SI	Steel	5.5
SPL 400	850	3611	1806	400	46	300	25	SPL400NBR	SPL400SI	Steel	7.6
SPL 500	1050	5778	2889	500	46	400	25	SPL500NBR	-	Steel	12
SPL 600	1300	7944	3972	600	46	500	25	SPL600NBR	-	Steel	18

(1) Actual force of the suction cup in use with 65% vacuum and including a safety factor of 2 for horizontal handling and a factor of 4 for vertical handling.

(2) f = Deflection of the suction cup.

(3) Thickness of the steel fitting: 8 mm

Standard internal threads

The threads given below are for mounting on the COVAL spring systems (not supplied with the suction cup).

RSC1: specify **G38 RS1** in the order number

RSC2: specify **G38 RS2** in the order number

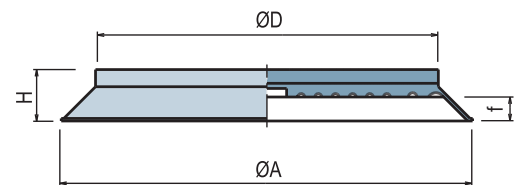

Internal Thread

	TS5 + IFA 12120	RSC1 (1)	RSC2 (1)
SPL 240	■	■	-
SPL 340	■	■	■
SPL 400	-	-	■

(1) A G3/8" internal thread is available for connection to the vacuum system.

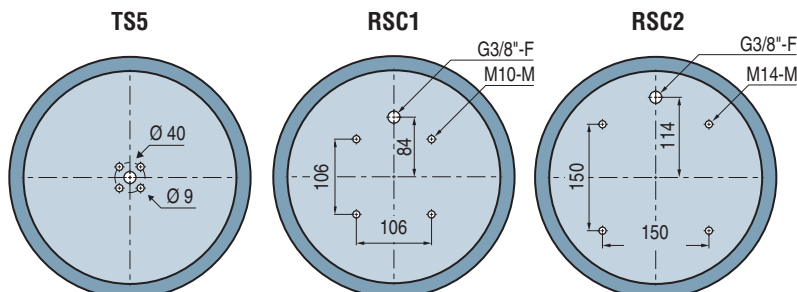
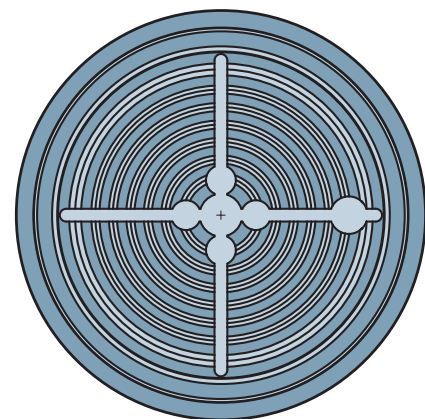

The values represent the average characteristics of our products.
Note: All dimensions are in mm

Accessories

Suction cups from the SPL series can be mounted on RSC series spring systems. SPL 240 suction cups can be mounted on the IFA 12 120 fitting and the TS560 spring system. See page 4/5.



For all orders, please specify the part number from characteristics table and any required threadings
E.g.: **SPL240NBRG38RS1**

STEEL

Steel Suction Cups with Bonded Seal With Bonded Seal

For horizontal handling of heavy loads (very thick sheet metal) or objects with an uneven surface such as concrete slabs or wood, etc.

Advantage: wide selection of shapes and sizes.

Materials

Body Painted steel
Foam seal Nitrile

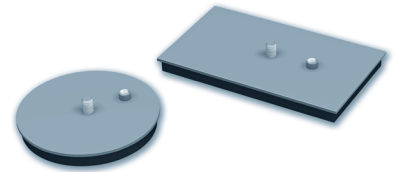

Industry-specific application

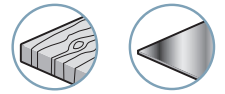

Types of use



Suction Cup Characteristics

Round suction cups				Rectangular suction cups								
	Ø A	H	$(N)^{(1)}$		L	I	H	M1/M2	Rac. ⁽²⁾	$(N)^{(1)}$	Type of seal	
5020	150	25	311	6020	175	115	25	40	G1/4"-F	332	BM 2020 SPTR	
5028	170	25	433	6028	215	115	25	45	G1/4"-F	426	BM 2020 SPTR	
5035	190	25	571	6035	225	125	25	50	G1/4"-F	513	BM 2020 SPTR	
5050	210	25	737	6050	250	150	25	60	G1/4"-F	751	BM 2020 SPTR	
5085	260	25	1235	6085	305	180	25	70	G1/4"-F	1206	BM 2020 SPTR	
5150	350	35	2145	6150	410	250	35	80	G3/8"-F	2159	BM 3030 SPTR	
5240	420	35	3308	6240	480	310	35	100	G3/8"-F	3416	BM 3030 SPTR	
5330	500	35	4940	6330	575	330	35	120	G3/8"-F	4521	BM 3030 SPTR	
5500	580	35	6897	6500	705	385	35	140	G3/8"-F	6811	BM 3030 SPTR	

(1) Force measured at 65% vacuum including a factor of 2.

Dimensions

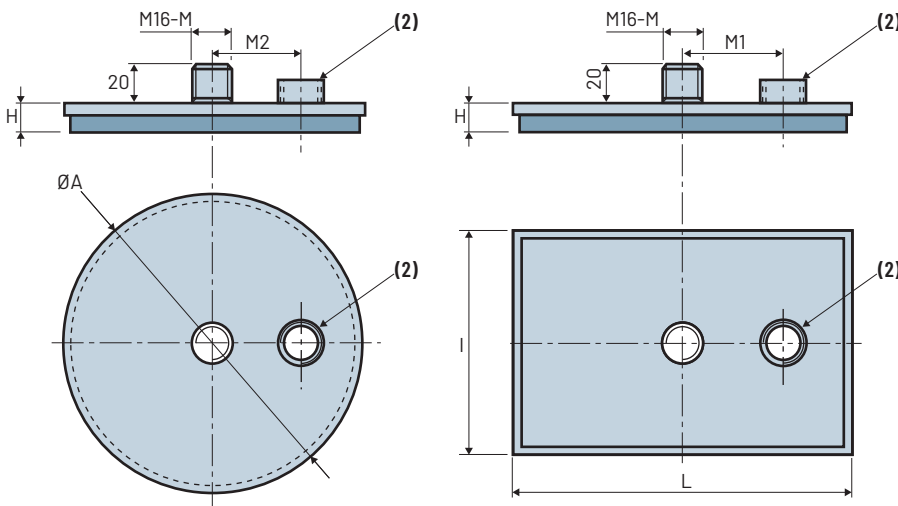

Accessory

- Ring fitting
E.g.: 5000AN

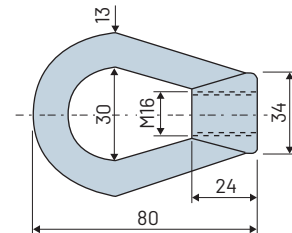

The values represent the average characteristics of our products.
Note: All dimensions are in mm

Specify the part number e.g.: 5020
Please refer to the characteristics table above.

Option

Spring system mounting, see page 4/5.

Suction Cup Accessories

Chapter 4

4

TS11



Level Compensators

- Stroke available from 7 to 40 mm
- Protected internal spring
- The TS 11 series spring systems are recommended for horizontal handling of objects located on different levels. The spring function also ensures the gripping points are applied on the same plane when gripping using multiple suction cups.

P_{4/3}

TS



Level Compensators TS1 – TS2 – TS3

- 4 models
- 5 to 70 mm stroke available
- TS Series spring systems are recommended for horizontal handling of parts at different levels. The spring function also ensures the gripping points are applied on the same plane when gripping using multiple suction cups.

P_{4/4}

TS



Level Compensators TS4 - TS5

- 3 models available
- Stroke 40 mm and 60 mm
- Available connections to suction cups: G3/8"-M and G1/2"-M
- TS Series spring systems are recommended for horizontal handling of parts at different levels. The spring function also ensures the gripping points are applied on the same plane when gripping using multiple suction cups.

P_{4/5}

RSC



Multi-Compensator Systems

- 2 models
- 30 mm stroke + 10° ball-joint effect
- Possibility of mounting on square tube with fitting system
- The system of 4 compensated springs is particularly recommended for horizontal handling requiring large diameter suction cups. The springs compensate for different levels between the suction cups (ball-joint effect).

P_{4/5}

TSOP



Anti-Rotation Level Compensators

- 4 models
- Anti-rotation
- 7 to 40 mm stroke available
- Protected spring
- The TSOP series anti-rotation spring systems are used for horizontal handling of objects at different levels. The anti-rotation function ensures that objects are always gripped in the same position.

P_{4/6}

TSOG



Anti-Rotation Level Compensators

- 8 models
- Anti-rotation
- 10 to 80 mm stroke available
- Protected spring
- The TSOG series anti-rotation spring systems are used for horizontal handling of objects at different levels. The anti-rotation function ensures that objects are always gripped in the same position.

P_{4/7}

Suction Cup Accessories

Chapter 4

L



Mounting Extensions

- 4 ranges (G1/4"-M, G1/8"-M, G3/8"-M and G3/8"-F)
- 3 possible strokes

- The L series extensions are used for gripping on various levels using the same installation plate. These extensions are adjustable to different heights.

P 4/8

Flow Control Fittings



Groups 1 and 2

- 13 models
- (Hollow screw or hollow shaft fitting)

- These fittings are designed for installations requiring a large number of suction cups connected to the same vacuum source, particularly for situations where parts may be missing in the layer to be handled. Using flow-controlled fittings reduces the loss of flow and therefore optimizes the size of the vacuum generator.

P 4/10

PMG2



Mechanical Feelers

- Mechanical feelers
- 5 models
- For VP series Ø30 to 60 mm suction cups

- The PMG2 series mechanical feelers are mounted on VP series diameter 30 to 60 mm flat suction cups in all types of material. The feeler is activated by the object to be handled, causing it to open and free the route for the vacuum.

P 4/11

IMU



Axial Ball-Joints

- Ball-joint fitting
- 4 models

- IMU series ball-joints are recommended for gripping rounded products.
- When installed on a flat suction cup, they provide greater force than a bellows suction cup.

P 4/12

CSP



Piloted Safety Valves

- Vacuum check-valve
- Directly mounted on the suction cup
- Release by blow-off

- The piloted safety valve CSP series mounts directly on the suction cup and allows to maintain the vacuum in it, in case of emergency stop or malfunctioning of the vacuum generator. The controlled dropping is done by connecting the fitting attached to the compressed air.

P 4/13

BM

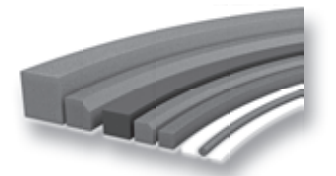

Foam Seals

- Foam strip (airtight cells)
- 9 models
- 2 types of material (Nitrile and Natural rubber)

- The foam strip is designed for gripping products with an uneven or ridged surface: sawn wood, metal sheets, flat surfaces with bumps or hollows.
- All granular surfaces to which suction cups cannot adhere correctly and therefore cannot be airtight.

P 4/14

TS 11

Level Compensators



The TS 11 series compensated spring systems are recommended for horizontal handling of objects at different levels. The spring function also ensures that the gripping points are applied on the same plane when gripping with multiple suction cups.

- Protected spring.

Materials

Spring Stainless steel
Tubing Zinc-plated steel
Slider Brass

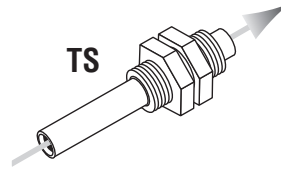

4

TS 11

Characteristics

References	A	F1	F2	C	D	L	1	2	k (N/mm)	Frep (N)	(g)
TS11 7	M5-F	M5-F	G1/8"-M	7	19	43	7	14	0.68	1.3	20
TS11 10	M5-F	M5-F	G1/8"-M	10	22	49	7	14	0.45	1.8	22
TS11 20	M5-F	M5-F	G1/8"-M	20	39	76	7	14	0.24	1.7	33
TS11 40	M5-F	M5-F	G1/8"-M	40	64	121	7	14	0.13	1.6	50

Note: All dimensions are in mm

C = Stroke

k = Spring stiffness

Frep = Force at rest

TS11

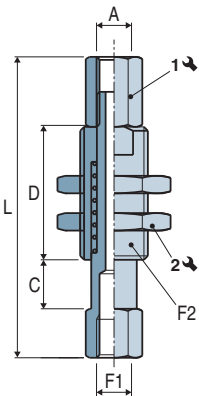

Suction cup mounting

The TS 11 series spring system can be fitted on all suction cups in group 1 (VP, VSA, VS Ø 5 to 25 mm) for IM21 and on suction cups in series VPG 5 to 20.



Please specify the part n° e.g.: TS1140
 See part n° table above.

TS

Level Compensators



TS series compensated spring systems are recommended for horizontal handling of parts at different levels. The spring function also ensures that the gripping points are applied on the same plane when gripping with multiple suction cups.

Materials

- Spring** Stainless steel
- Tubing** Zinc-plated steel
- Slider** Brass

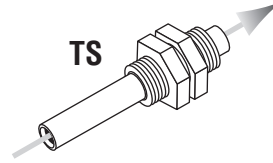

Characteristics

Models	TS1				TS2				TS3				TS1.20 LG
Stroke	05	10	20	30	10	30	50	70	10	30	50	70	20
L	29	39	59	79	48	88	128	168	48	88	128	168	59
k (N/mm)	0.36	0.15	0.07	0.045	0.9	0.2	0.115	0.08	0.9	0.2	0.115	0.08	0.07
Frep (N)	1.00	1.70	1.45	2	8.1	4.2	4.5	4.5	5.1	4.2	4.5	4.5	1.45

Note: All dimensions are in mm

k = Spring stiffness

Frep = Force at rest

4
TS

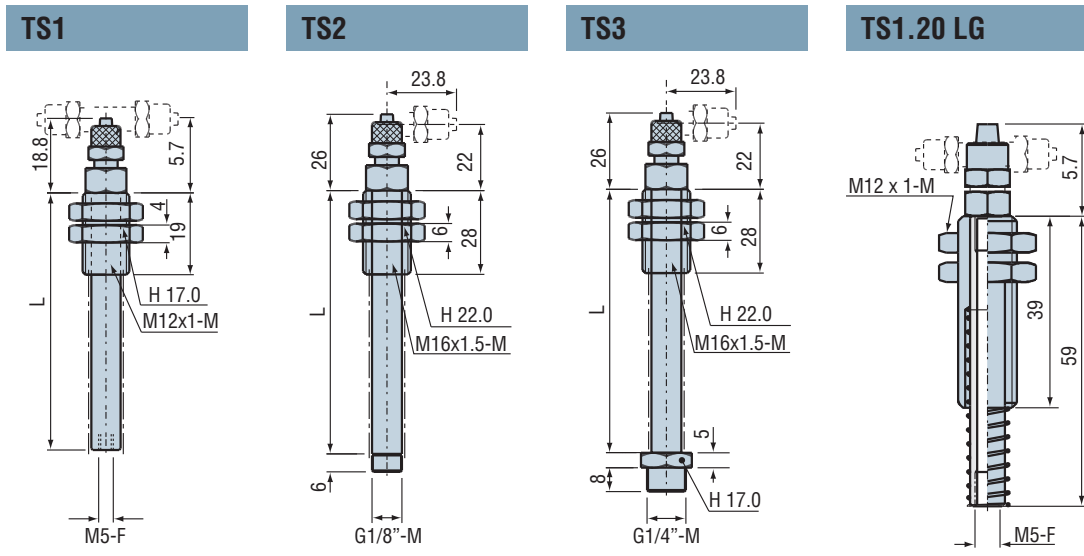

Please specify the part n° e.g.:
Model + Spring stroke + Fitting
e.g.: TS350C46

1: Model	2: Spring stroke	3: Fittings (for TS series)
TS1	05 - 10 - 20 - 30 (TS1)	D46 (Straight 4 x 6 - TS1, TS2, TS3)
TS2	10 - 30 - 50 - 70 (TS2, TS3)	D68 (Straight 6 x 8 - TS2, TS3)
TS3		C46 (Elbow 4 x 6 - TS1, TS2, TS3)
		C68 (Elbow 6 x 8 - TS2, TS3)
		T46 ¹ (T-shape 4 x 6 - TS1)
		N ² (Without fitting)

Advantage of the TS120LG
 The adjustment height is twice that of the standard TS1 spring system and its spring is protected.

(1) versions T46 and T68 on request for TS2 and TS3.
 (2) For TS1 model, vacuum connection M5-F and for models TS2 and TS3 vacuum connection G1/8"-M.

TS

Level Compensators



Characteristics

Models	TS4 50	TS5 60
Stroke	45	60
L	196	234
k (N/mm)	0.47	1.23
Force at rest (N)	4	0

k = Spring stiffness

Materials

Spring Stainless steel
Tube Zinc-plated steel
Slider Zinc-plated steel

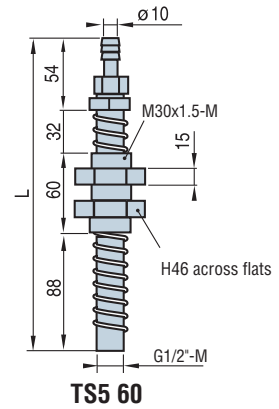
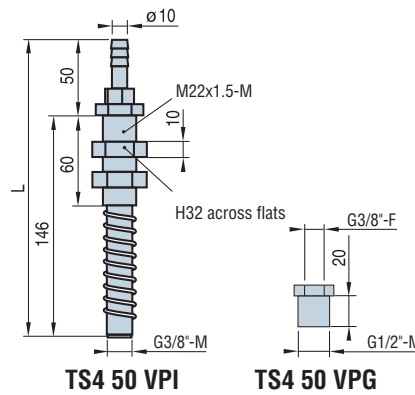

Note: All dimensions are in mm

4

TS - RSC

RSC

Multi-Compensator Systems

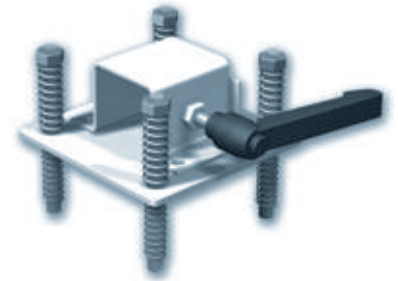

Use

The system of 4 compensated springs is particularly recommended for horizontal handling requiring large diameter suction cups. The upper stainless steel springs act as dampers for all vertical movements. They compensate for different levels between the suction cups. The system of 4 compensated springs mounted in a square gives the assembly a ball-joint effect.

Materials

Spring Stainless steel
Damper Stainless steel
Studs A 60
Colour Yellow RAL 1023

Characteristics

Models	Max. load (N)	Stroke under traction	Vertical force (N)	Maxi. weight (kg)	Ball-joint angle	Tube mounted	A	B	C	D	E	F	G	H	I	J	K	L
RSC1	2000	30	160	1.3	10°	50	140	106	88	50	M8-F	M10-M	8	120	5	52	52	9
RSC2	4000	30	340	3.4	10°	80	190	150	114	80	M8-F	M14-M	8	130	8	83	83	13

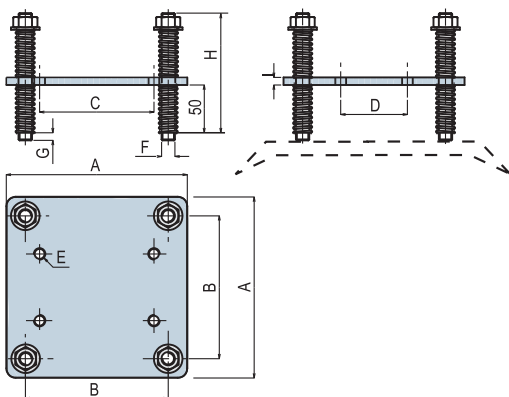

RSC option...VAC

Square tube mounting options (Tightening by indexable lever).

- RSC1 VAC on 50 mm square tube.
- RSC2 VAC on 80 mm square tube.

Note: All dimensions are in mm

Note:

- RSC1: for SPL 240 suction cups, 5085 steel suction cups.
- RSC2: for SPL 340 suction cups, 5150 steel suction cups.



Please specify the part:
Model + Type + Tube mounting option
 e.g.: RSC2VAC

1: Model	2: Type	3: Tube-mounting option
RSC	1	max. 2000 N
	2	max. 4000 N
	VAC	with tube-mounting option

TSOP

Anti-Rotation Level Compensators



The TSOP and TSOG series spring systems are anti-rotation spring systems. They are used for horizontal handling of parts at different levels. The anti-rotation function ensures that objects are always gripped in the same position. The TSOP range is designed for applications requiring very precise handling.

- The hexagonal rod prevents the suction cup from rotating.
- Protected spring.

Characteristics - TSOP

References	A	F1	F2	C	D	L	1	2	k (N/mm)	Frep (N)	(g)
TSOP 107	M5-F	M5-F	G1/8"-M	7	18	42	7	14	0.68	1.3	20
TSOP 110	M5-F	M5-F	G1/8"-M	10	22	49	7	14	0.45	1.8	22
TSOP 120	M5-F	M5-F	G1/8"-M	20	39	73.5	7	14	0.24	1.7	33
TSOP 140	M5-F	M5-F	G1/8"-M	40	64	118.5	7	14	0.13	1.6	50

Note: All dimensions are in mm

C = Stroke

k = Spring stiffness

Frep = Force at rest

Materials

- Spring** Stainless steel
- Tubing** Anodized aluminum
- Slider** Nickel-plated steel

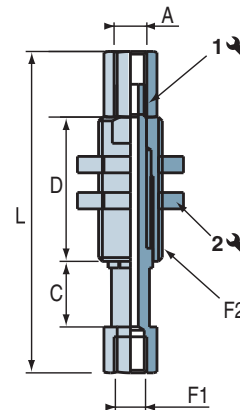

4
TSOP



Please specify the part e.g.: TSOP140
See part n° table above.

TSOG

Anti-Rotation Level Compensators



The anti-rotation spring system TSOG serie allows to compensate for differences in height and to handle parts at different levels with ensuring precise positioning of the suction cup.

They are perfect to equip end of arm tooling in plastics processing and packaging.

The TSOG range is designed for applications requiring very precise handling.

- Lightness thanks to the aluminium design
- Protected spring
- Accurate anti-rotation system
- Wide range of stroke and connections

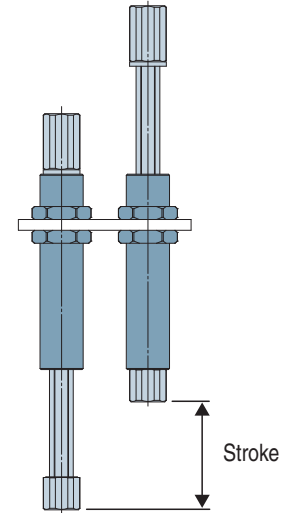

4
TSOG

Characteristics - TSOG

References	A	F1	F2	C	B	D	E	G	L	↻ 1	↻ 2	↻ 3	k (N/mm)	Frep (N)	Fcomp (N)	⚖️ (g)
TSOG110FM12	M5-F	M5-F	M12x1-M	10	17	25	5.5	5.5	60	10	15	10	0.21	1.9	4.1	17
TSOG125FM12	M5-F	M5-F	M12x1-M	25	17	44	5.5	5.5	94	10	15	10	0.12	2	5	23
TSOG220FM16	G1/8"-F	G1/8"-F	M16x1-M	20	20	38.5	9	7	100	12	19	12	0.27	3.6	9	36
TSOG235FM16	G1/8"-F	G1/8"-F	M16x1-M	35	20	58.5	9	7	131.5	12	19	12	0.15	4.3	9.5	46
TSOG325FM20	G1/4"-F	G1/4"-F	M20x1.5-M	25	23	50	10	10	113	16	24	16	0.27	4.1	11	64
TSOG350FM20	G1/4"-F	G1/4"-F	M20x1.5-M	50	23	82.5	10	10	170.5	16	24	16	0.14	4.3	11.4	90
TSOG440FM25	G3/8"-F	G3/8"-F	M25x1.5-M	40	33	71	11	11	159	22	32	22	0.27	5.6	16.5	164
TSOG480FM25	G3/8"-F	G3/8"-F	M25x1.5-M	80	33	121	11	11	249	22	32	22	0.14	6	17	231

Note: All dimensions are in mm

C = Stroke

k = Spring stiffness

Frep = Spring force

Fcomp = Force at rest

Materials

- Spring** Stainless steel
- Tubing** Anodized aluminum
- Slider** Anodized aluminum
- Nuts** Anodized aluminum

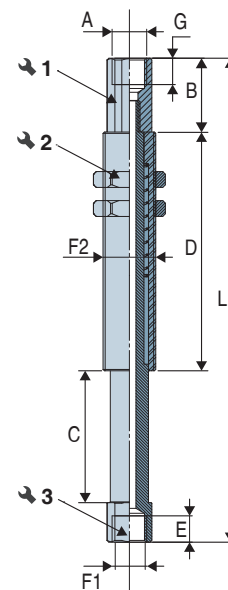

Please specify the part e.g.: TSOG350FM20
See part n° table above.



Mounting Extensions



The L series extensions are used for gripping on various levels using the same installation plate. These extensions are adjustable to different heights. This system is especially useful for 2.5 bellows type suction cups, as height adjustment is made easier by the deflection of the suction cup. Spring systems should be chosen, instead, for flat suction cups with low deflection.

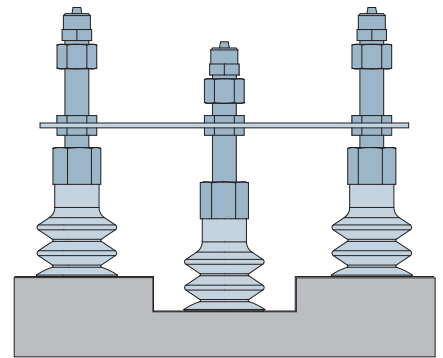

Materials

Threaded rod and nut Brass
Screwed vacuum fitting Nickel-plated brass

Characteristics

Models	A ⁽¹⁾			B	C	h		Ød	ØL	D	P
G1/8"-M	22	42	52	25	19	3	14	6	G1/8"-M	-	-
G1/4"-M	19	49	69	29	24	4	19	9	G1/4"-M	-	-
G3/8"-F	19	49	69	20.5	19.5	4	23	-	G3/8"-F	19	22
G3/8"-M	19	49	69	20.5	19.5	4	23	10	G3/8"-M	-	-

(1) Other lengths available on request for a minimum quantity of 10 pieces.



G1/4"-M - G1/8"-M

Straight

Elbow

G3/8"-F

Straight or elbow 6x8 or 8x10

G3/8"-M

Straight or elbow 6x8 or 8x10

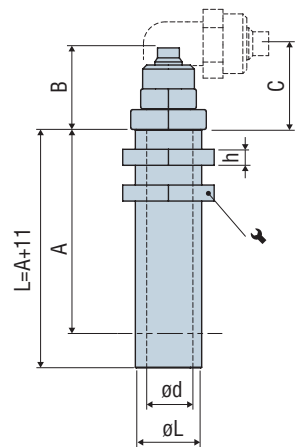
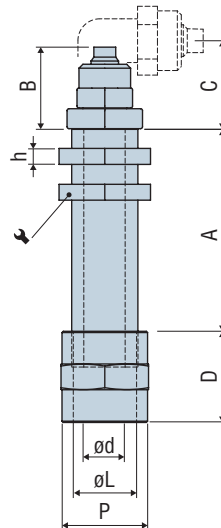
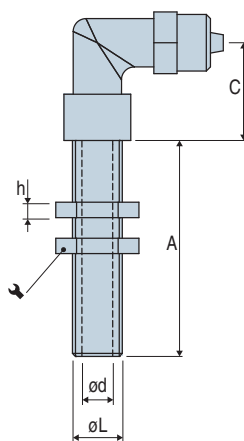
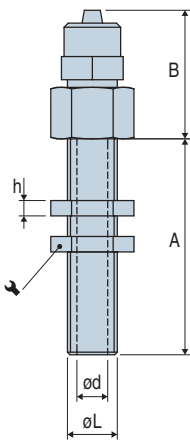

Please specify the part:
Model + Thread + Adjustable stroke + Fitting + Suction cup fitting
 e.g.: L1449C68F

1: Model	2: Thread	3: Adjustable stroke	4: Fittings	5: Suction cup fitting G3/8" version
L	18 G1/8"	22 - 42 - 52	G1/8"	D46 Straight 4 x 6
	14 G1/4"		G1/4"	D68 Straight 6 x 8
	38 G3/8"	19 - 49 - 69	G3/8"	C46 Elbow 4 x 6
				C68 Elbow 6 x 8
				N Without fitting
			D810 Straight 8 x 10	
			C810 Elbow 8 x 10	

Note: All dimensions are in mm

G3/8" extensions are compatible with C Series high performance suction pads (see page 2/59) and CTC Series (see page 2/63).

Miscellaneous Gripping

Principle

In many cases when using a multi-suction cup installation, some of the cups will not be covered by the product(s) to be handled. This leads to a high risk of reduced grip from the covered suction cups, or may even prevent them gripping at all.

Examples

- Gripping of panels, sheet metal, etc. in a wide variety of sizes by a vacuum lifter equipped with suction cups.

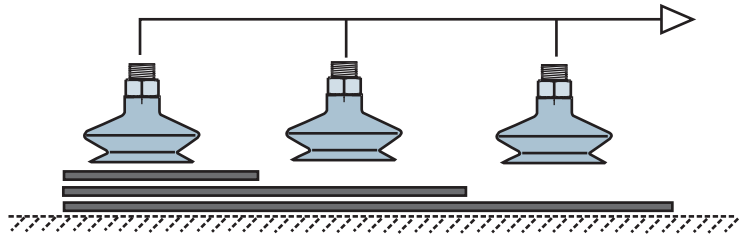

- Uncertain position of the object(s).

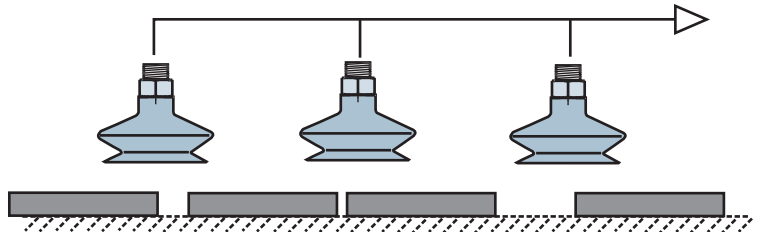

- Gripping several objects at one time, some of which may be missing.

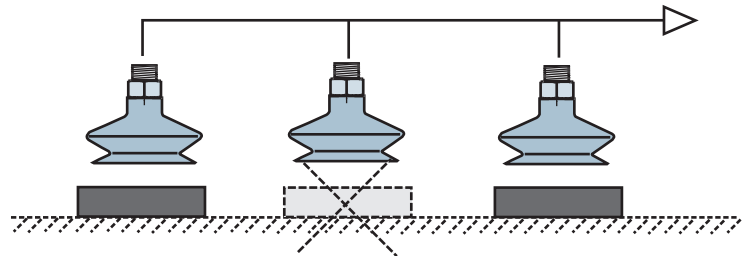

Solutions

- Independent ejector

Mounting an ejector for each suction cup guarantees the installation will operate perfectly even if one or more suction cups are not covered.

The COVAL solutions are the VR, GVR, CVP and CVPC series micro-ejectors.

For further information, see chapter 6.

- Flow control fittings

Flow control fittings are incorporated as part of the suction cup mounting, thus reducing leakage in that cup with no part present during the vacuum cycle.

This technical solution is particularly suitable for vacuum grippers with a large number of suction cups.

To determine the diameter of the nozzle, COVAL has developed a specific CAD.

- Mechanical feelers

See following pages. COVAL offers four solutions depending on the application, with their advantages and drawbacks.

Flow Control Fittings

Groups 1 and 2



These fittings are designed for installations with a large number of suction cups connected to the same vacuum generator (vacuum gripper technology), particularly in cases where there may be objects missing from the layer of objects to be handled. Using flow-controlled fittings reduces the loss of flow and therefore optimizes the size of the vacuum generator.

Caution, do not use this type of fitting for applications in a dusty environment.

Characteristics

References	ØA	ØD	B	C
IM5 MVSD1.1	M5-M	1.1	8	5
IM21 SP058	M5-M	0.45	4.5	5
IM21 SP094	M5-M	0.6	4.5	5
IM60 SP335	M6-M	0.6	7	11
IM60 SP387	M6-M	1.2	7	11
IM60 SP461	M6-M	0.9	7	11
IM60 SP483	M6-M	1	7	11
IM60 SP510	M6-M	1.7	7	11
IM60 SP511	M6-M	2.5	7	11
IMCM5 D0.6	M5-M	0.6	8	5
IMCM5 SP691	M5-M	1.1	8	5
IMCM5 SP701	M5-M	1.5	8	5

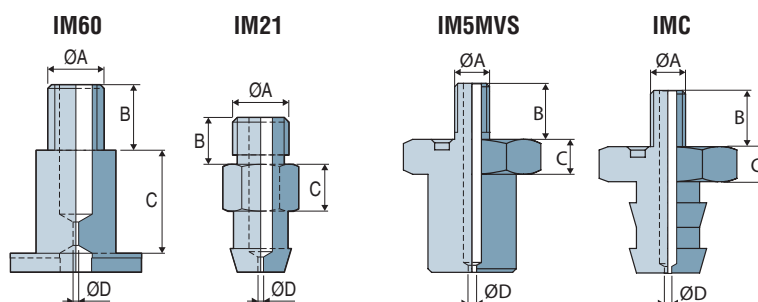

4

Maximum suction per nozzle diameter

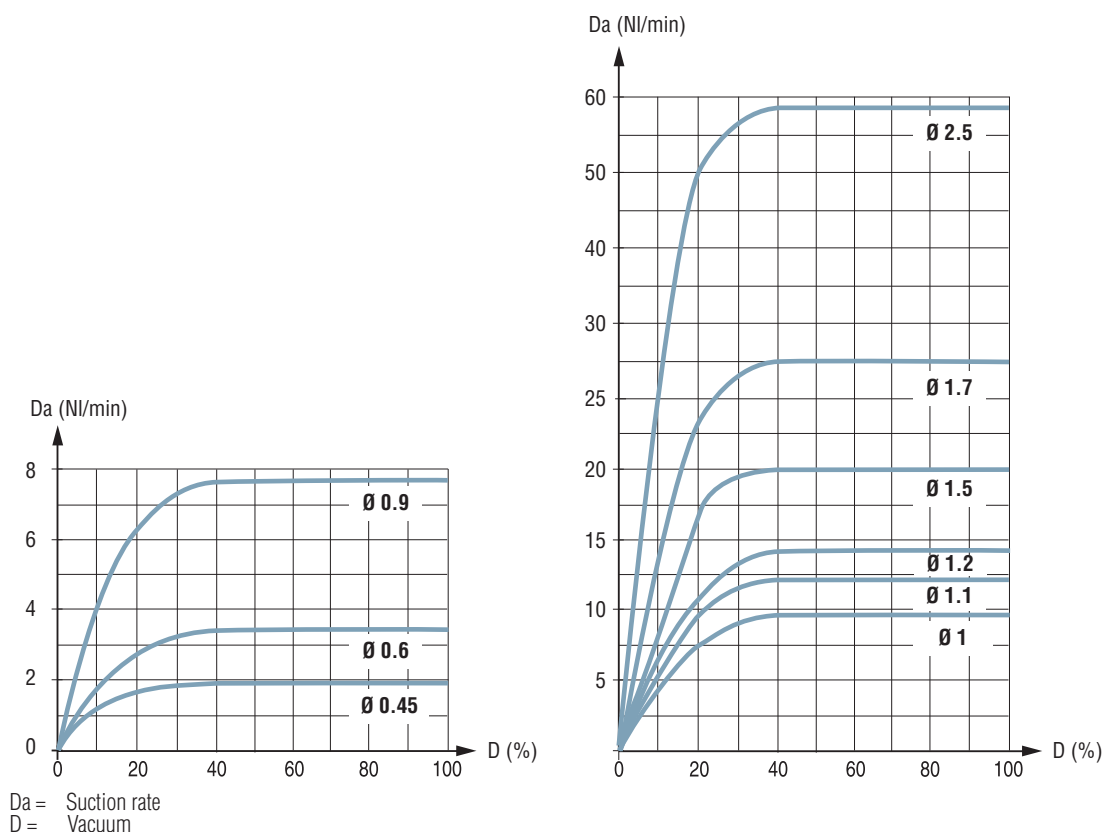

 Please specify the part e.g.: IM60SP387
See part n° table above.

Note: All dimensions are in mm

PMG2

Mechanical Feelers



The PMG2 series mechanical feelers are mounted on VP series diameter 30 to 60 mm flat suction cups in all types of material (group 2 suction cups).

The mechanical feeler blocks the path from the vacuum source to the suction cup.

The feeler is actuated by the object, causing it to open and free the path for the vacuum.

Materials

Body Nickel-plated brass

Spring Stainless steel

Feeler Delrin and brass

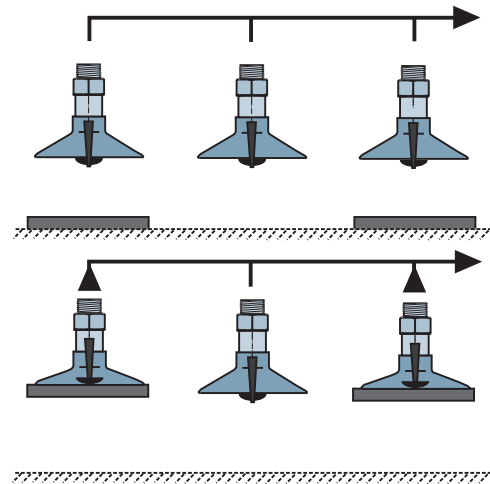

4

PMG2

Advantages

- Simple to install and operate.
- Very efficient air-tightness for non-covered suction cups.
- Little risk of marking delicate objects, as the feeler has a rounded surface.

Mounting

The feelers are mounted by press fitting. It is preferable to allow us to assemble the feeler onto the suction cup.

Characteristics

	VP 30	VP 35	VP 40	VP 50	VP 60
d (mm)	3.9	2.9	2.9	0.9	0.9
H (mm)	19	20	20	22	22

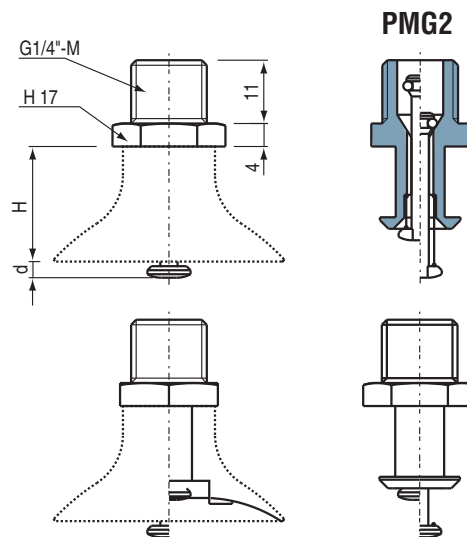

Leakage rate

No leakage if all the suction cups are correctly placed. This represents substantial savings in power with regard to the vacuum source: pneumatic ejector or electric vacuum pumps.



Please specify the part: PMG2

Accessories

Mounting on spring or ball-joint systems (see chapter 4).

IMU

Axial Ball-Joints



IMU series ball-joints are recommended for gripping rounded or rotating products.

When installed on a flat suction cup, they provide greater force than a bellows suction cup.

The vacuum connection is axial and sealing is ensured by a special seal always in contact with the spherical articulation.

The suction pad installed over the axial ball joint is free to rotate on its axis around 360° and can incline up to 15°

The ball joints are manufactured entirely in copper except the spherical joint made in stainless steel.

Materials

Ball-joint Zinc-plated steel and brass

Seal Nitrile (NBR)

Characteristics

References	G	G1	C2	C	E ↻	E1 ↻	H	 (g)
IMU 18	G1/8"-F	G1/8"-M	8	8.5	11	18	43	40
IMU 14	G1/4"-F	G1/4"-M	8	10	15	18	44.6	56
IMU 38	G3/8"-F	G3/8"-M	13	13	26	28	63.3	206
IMU 12	G1/2"-F	G1/2"-M	15	17	26	28	72.3	232

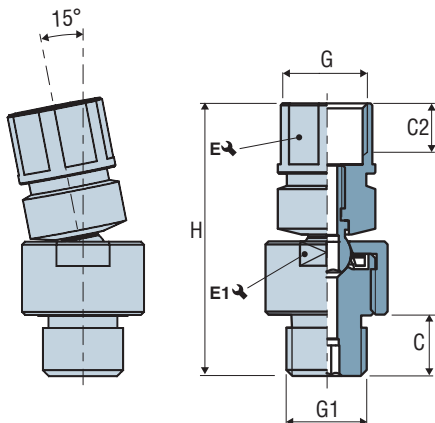

Please specify the part e.g.: IMU14
See part n° table above.

Note: All dimensions are in mm



The piloted vacuum valve CSP series mounts directly on the suction cup and allows to maintain the vacuum in it, in case of emergency stop or malfunctioning of the vacuum generator.

The controlled dropping is done by connecting the fitting attached to the compressed air.

Note: The empty valve is not a positive safety feature. Regular maintenance is needed to ensure the proper functioning of the valve.

Materials

Valve Nitrile (NBR)

Body Anodized aluminum

Filter Stainless steel screen 200 μ

4

CSP

Characteristics

Reference	$\varnothing G$	$\varnothing G1$	D	F	L	J	E 
CSP 14	G1/4"-F	G1/4"-M	4x6	25	33	12.8	21

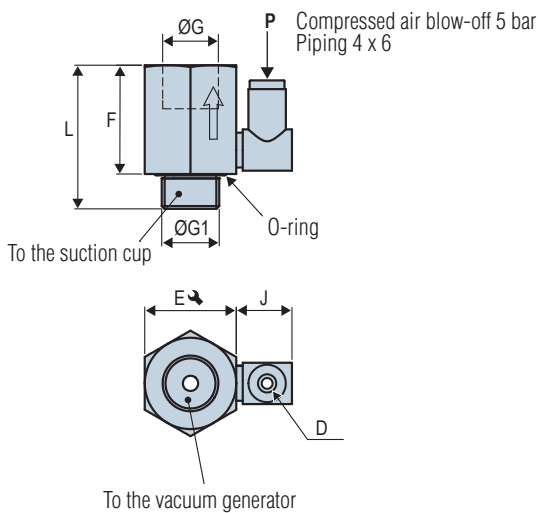

Mounting

- One piloted vacuum valve by suction cup.
- Blow-off pressure, minimum 5 bar.

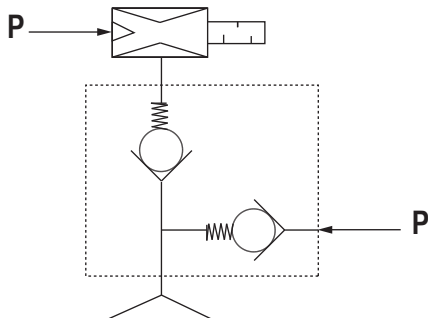

Please specify the part e.g.: CSP14
See part n° table above.

Note: All dimensions are in mm

BM Foam Strips



Industry-specific applications



Nitrile foam strip: 10m roll

Mounting

Mounting with contact adhesive or flush-mounted at a depth adapted to the height and potential flush-mounting of the seal subject to the vacuum: 50% to 70% of the new height.

References	A	B
BM 1510	15	10
BM 1010	10	10
BM 1515	15	15
BM 2020	20	20
BM 3030	30	30

Support

- All supports, particularly steel, aluminum, etc.
- Closed cells.
- Tube of neoprene adhesive (120 ml): Part No. 095.99.006.

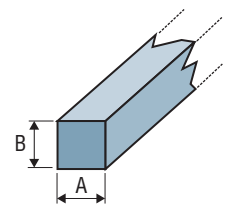

Nitrile beveled foam strip: 10m roll

- The beveling facilitates gripping of products with uneven surfaces.
- Closed cells.
- Contact adhesive reference: BOSTIK 1400 (Neoprene adhesive).

References	A	B
BM 2020 SPTR	20	20
BM 3020 SPTR	20	30
BM 3030 SPTR	30	30

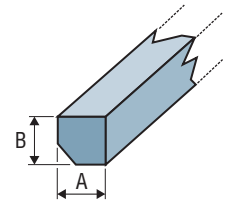

Natural rubber foam strips: Length 1m

- Flush-mounting.
- Use with turbine (strong suction) for gripping products with very uneven surfaces, such as slabs of washed gravel.
- Open cells.
- Contact adhesive reference: BOSTIK 1400 (Neoprene adhesive)

Reference	A	B
BMS 3025	30	25

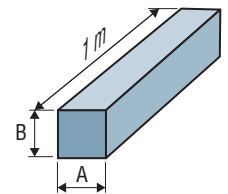

Please specify the part e.g.: BM1510
See part n° table above.

Note: All dimensions are in mm

Vacuum Pumps Overview

Chapter 5

General Points	p. 5/2
Choosing a Vacuum Pump	p. 5/3
Comparison of Vacuum Pumps and Air Amplifiers	p. 5/4
COVAL's Family of Intelligent Vacuum Pumps	p. 5/6
Vacuum Pump Range	p. 5/8
Evacuation Time and Weight of Vacuum Pumps	p. 5/11

Vacuum Pumps Overview

General Points

What is vacuum?

5

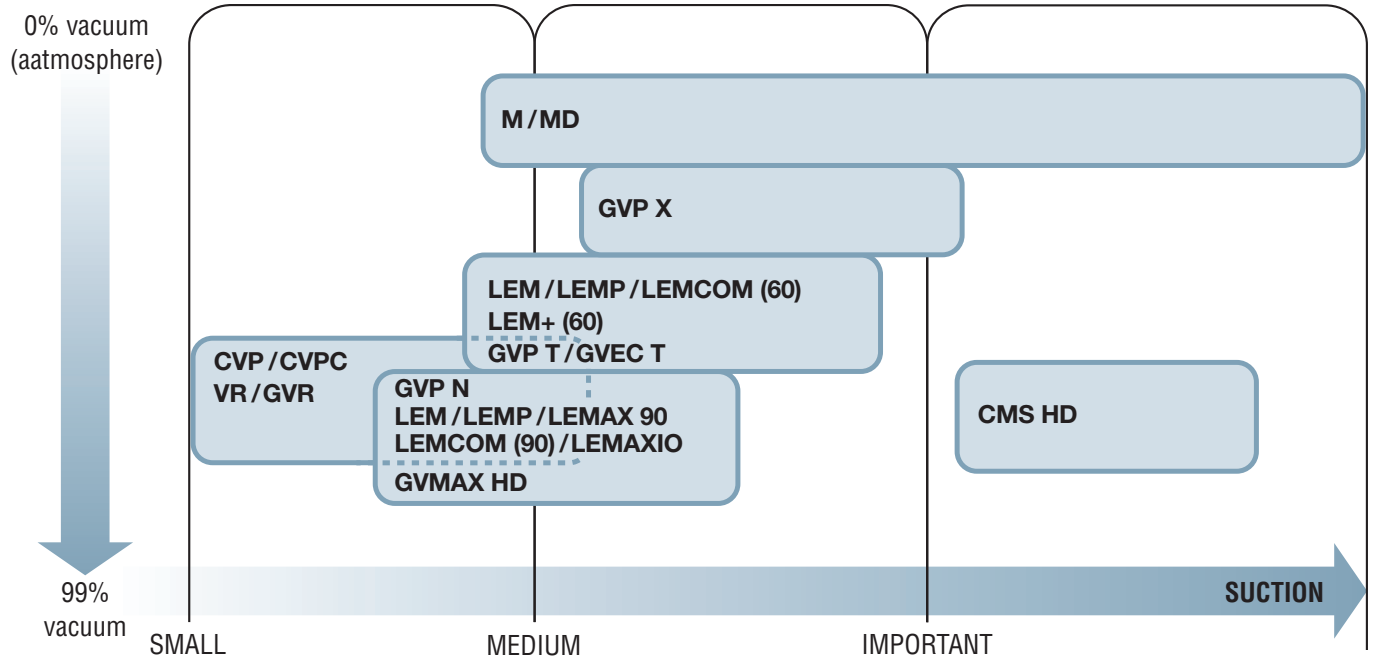

HOW A VENTURI WORKS

The COVAL vacuum pump works on the Venturi principle. The filtered, non-lubricated compressed air in **A** is blown through nozzle **D** and speeds up. It then goes into mixer **E** and finally escapes through silencer **B**. The vacuum is caused by the pressure drop in the chamber around nozzle **D**. The air sucked in **C** follows the same route to end up in silencer **B**.

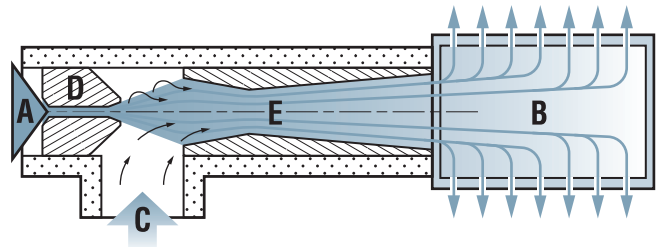

PRESSURE UNIT CONVERSION

Units	Bar 10 N/cm ² = 100 kPa	Atm kp/cm ²	Torr mm of Hg
Bar = 10 N/cm ² = 100 kPa	1	0.986923	750.0617
Atm = kp/cm ²	1.01325	1	760
Torr = mm of Hg	0.0013332	0.001316	1

CONVERSION ACCORDING TO THE PERCENTAGE OF VACUUM

%	Bar (10 N/cm ² = 100 kPa)	Atm (kp/cm ²)	mm of water column
10%	-0.101	-0.103	1000
20%	-0.203	-0.207	2000
30%	-0.304	-0.310	3000
40%	-0.405	-0.413	4000
50%	-0.507	-0.517	5000
60%	-0.608	-0.620	6000
70%	-0.709	-0.723	7000
80%	-0.811	-0.827	8000
90%	-0.912	-0.930	9000

Vacuum Pumps Overview

Choosing a Vacuum Pump

The role of the vacuum pump is to generate a vacuum relative to a specific capacity. For vacuum handling, this capacity generally consists of:

- the internal volume of the suction cups to be evacuated,
- the volume of the network (piping).

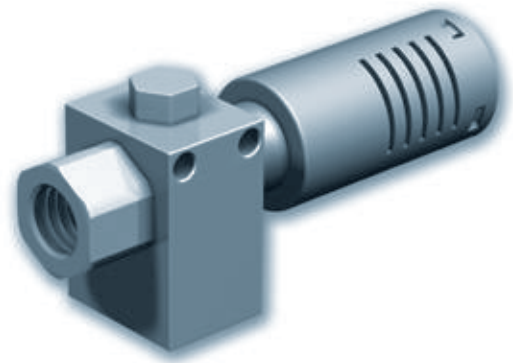

GRIPPING AIRTIGHT AND POROUS OBJECTS

Airtight objects

Only the volume of the cups and vacuum network needs to be considered. The choice of vacuum pump will correspond directly to the evacuation time required by the application. By nature of the product, it is ideal and more efficient to select pumps with a maximum vacuum level of 85% or more.

CALCULATING THE LEAKAGE RATE

First, choose a suction cup with a diameter compatible with the object to be gripped.

Second, equip a vacuum pump (with known characteristics) with a pressure gauge and a vacuum gauge. Then supply the pump with optimal pressure (e.g. 5 bar).

Finally, apply the suction cup to the surface to be tested.

Three possible cases may arise:

- The vacuum gauge indicates the maximum vacuum achieved for this type of pump: the object is airtight.
- The vacuum gauge does not measure any vacuum: choose a more efficient vacuum pump as the leakage rate is higher than the maximum vacuum pump flow.
- The vacuum gauge displays a vacuum value, e.g. -300 mb (30% vacuum), refer to the vacuum pump curve. Read the flow corresponding to -300 mb (e.g. 75 NI/minute).

Porous objects

In this case, it is not possible to fully evacuate the vacuum system. The leakage rate from the suction cup network must be considered as well as the volume. A vacuum pump equipped to handle this application will be one whose flow is significantly greater than that of the leakage in the system, thus allowing vacuum pressure to build. For these products, it is preferable to choose a pump with high flow rates and a reduced maximum vacuum level of 50-60%.

For example, the leakage rate at -300mb is measured at 75 NL/min for the suction cup used.

Using this data, calculate the forces to be applied to handle the object:

At -300mb the theoretical force of the suction cup is:

F = S x 0.3 with:

S = surface of the suction cup in cm², **F** in daN.

(-300 mbar = -0.3 bar, for calculation use 0.3).

To grip the object safely, (factor of 2 for horizontal gripping and 4 for vertical gripping), one must account for the varying characteristics of the vacuum pumps.

5

THINGS TO REMEMBER

"An installation must breathe properly".

The throughput for a machine includes:

- gripping time,
 - transfer time,
 - release time.
- Install vacuum pump as close as possible to the suction cups,
 - Choose suction cups with the smallest possible internal volume,
 - Identify suitable sizes of piping and fittings to limit pressure losses.

Vacuum Pumps Overview

Comparison of Vacuum Pumps and Air Amplifiers

AIR AMPLIFIER

Optimal usage zone: 0 to 12% vacuum.

Maximum usage range: 0 to 15% vacuum.

■ Applications:

TRANSPORT - DRYING - DEGASSING

Handling very porous, lightweight products: carpet, textiles, foam, etc...

Transporting small objects: granules, grains of coffee, rice, paperclips, etc...

Smoke extraction, degassing.



5

TYPES OF VACUUM PUMPS

■ Version 60% vacuum

Optimal usage zone: 30 to 55% vacuum.

Use of vacuum pumps optimized at 60% maximum vacuum implies high suction flow to account for the drop in vacuum pressure.

■ Version 85 % vacuum

Optimal usage zone: 55 to 80% vacuum.

The importance of a vacuum pump which can create an 85% vacuum is to generate high vacuum and therefore a high force/surface ratio.

■ Applications:

HANDLING - SUCTION - EMPTYING - DOSING

Handling porous, semi-porous and airtight products.

High-speed pick and place.

Air and/or liquid dosing.



COMMENTS

The optimal use zones recommended as follows are the most adapted to the different types of technology. However they are in no way restrictive or limiting.

The notes are valid for both COVAL product groups: air amplifiers and vacuum pumps and also apply to all products using the same technology.

NOTE

The following curves have been established using COVAL equipment: M 10 C air amplifier, LEM60X14 and LEM90X14 vacuum pumps.

The values given are values for identical compressed air consumption and optimal characteristics of each of the vacuum generation procedures.

Vacuum Pumps Overview

Comparison of Vacuum Pumps and Air Amplifiers

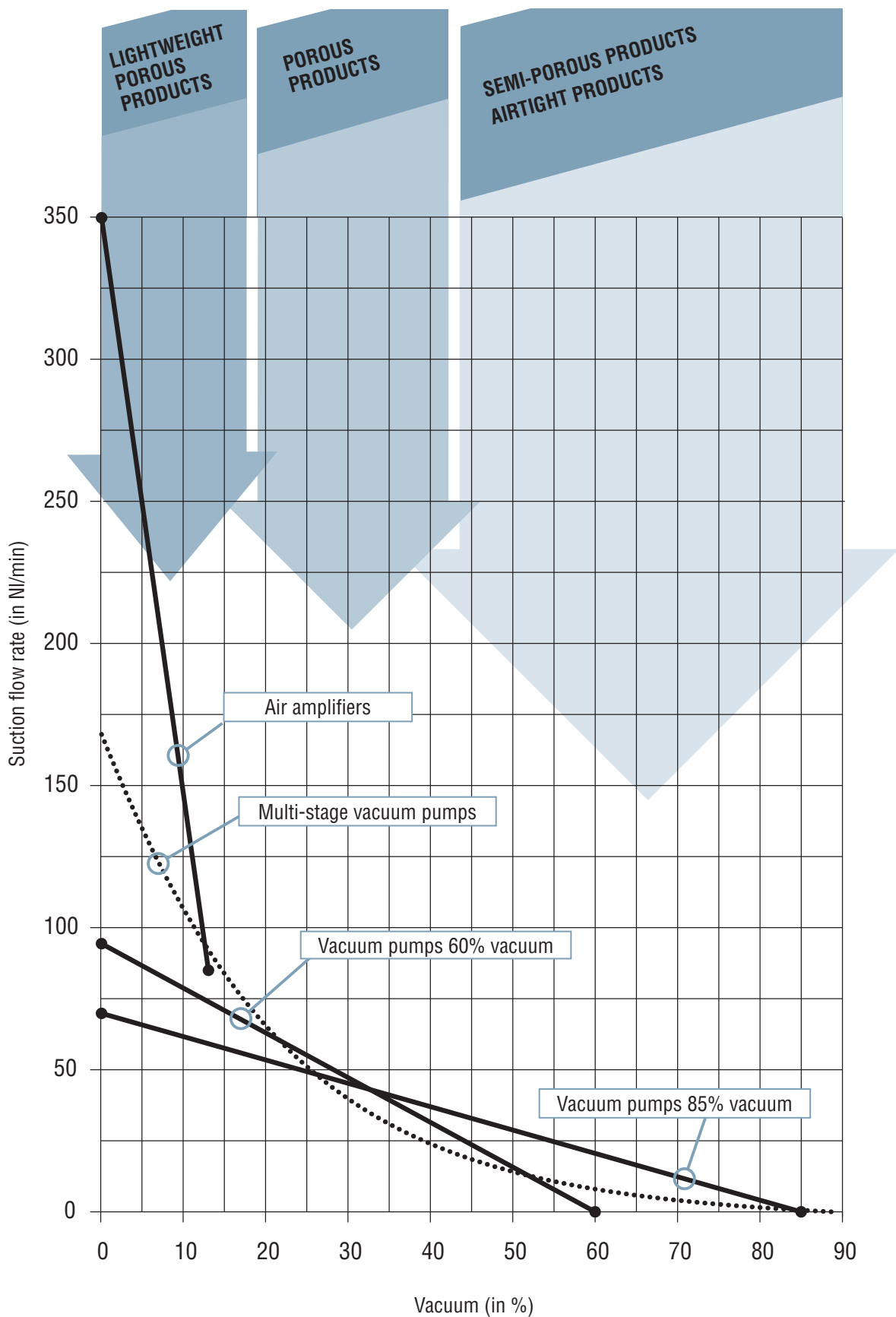

COVAL's Family of Intelligent Vacuum Pumps

Vacuum pumps are used in a wide variety of automated systems, primarily to generate and control vacuum in suction cups to ensure the gripping of objects. They must be easily integrated into a process and communicate the information necessary to ensure proper production.

To meet the expectations of manufacturers and the demands of automated applications, COVAL offers a complete range of vacuum pumps to meet different needs: vacuum levels, suction rates, control types, communication technologies, and energy savings.



Communication needs vary depending on the industry and application, but more and more, an efficient and real time communication system allows for increased flexibility of the machine.

In addition, the simplification of wiring and configuration is a benefit for integrators, while expanding the possibilities of diagnosis and optimization.

Key points of intelligent vacuum pumps



5

Functions	Model	LEMP	LEM	LEMAX	LEMAX IO	LEMCOM	LEM+	LEMAX+	GVMAX HD	CMS HD
Recommended for porous products		■	■			■	■			■
Recommended for airtight products				■	■	■		■	■	
Suction flow rate from 29 to 92 NI/min		■	■	■	■	■				
Suction flow rate from 125 to 275 NI/min							■	■	■	
Suction flow rate from 700 to 1600 NI/min										■
Maximum vacuum level: 60%		■	■			■	■			
Maximum vacuum level: 80 or 85%		■	■	■	■	■	■	■	■	■
Vacuum control			■	■	■	■	■	■	■	■
Blow-off control			■	■	■	■	■	■	■	■
Integrated pressure regulator (ASR)		■	■	■	■	■	■	■		
Powerful blow-off							□	□	□	
Electronic vacuum switch with display		□	□	■			□	■	■	□
Electronic vacuum switch					■	■				
Pressure sensor									■	□
Vacuum check-valve				■	■	■		■	■	
Automatic vacuum regulation (ASC)				■	■	■		■	■	
M8 connections		□	■	■	■	■				
M12 connections							■	■	■	■
Island Assembly Available		■	■	■	■	■			■	
SMART SWAP Quick-mounting system									■	
Field bus EtherNet/IP™ / PROFINET						■				
IO-Link					■				■	□
NFC									■	□

■: Standard or integrated □: Option

Energy Savings

COVAL is committed to making your vacuum handling system energy-efficient.

Our goal is to optimize the overall performance of your equipment by operating on the following three principles:

- Analyzing the system to identify the potential for savings.
- Selecting the most appropriate solution.
- Including COVAL energy-saving technologies, such as ASR and ASC, in our products.



ASR (Air Saving Regulator)

A "venturi pressure regulator" that guarantees optimized operation at 3.5 bar.

Ideal for gripping of porous products or rough surfaces.

Advantage: Up to **40 %** energy savings.



ASC (Air Saving Control)

A vacuum regulation system that auto-adjusts to the product being handled.

Ideal for gripping airtight products.

Advantage: Up to **90 %** energy savings.

COVAL's Family of Intelligent Vacuum Pumps

A vast ecosystem of vacuum pumps to meet all needs. From simple control to communication technologies designed for the industry of the future...

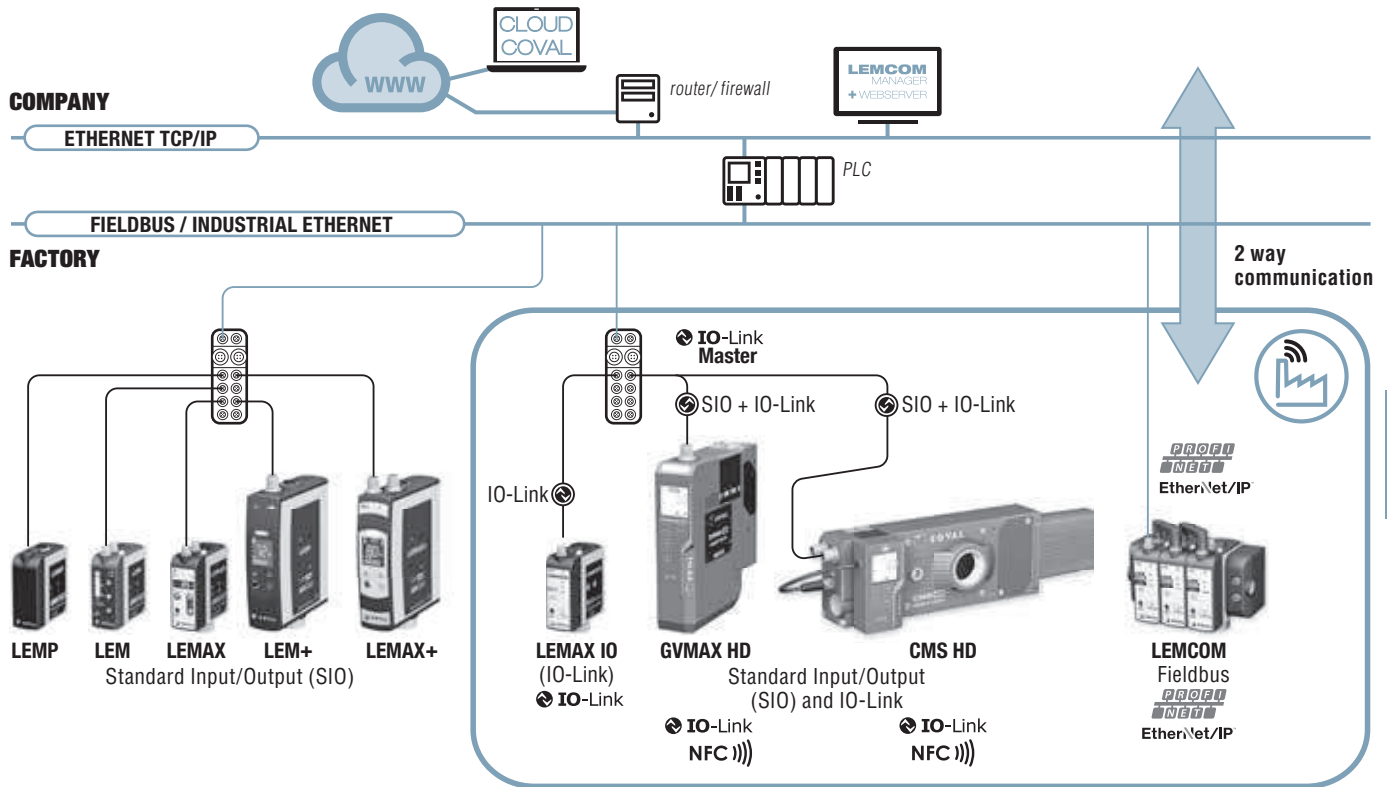

5

Key points of communication technology

Communication interface with the machine

Industrial Ethernet

- Supported buses: PROFINET, EtherNet/IP™.
- Direct connection to the machine's ethernet network.
- 2 cables for power and control of 1 to 16 vacuum pumps.



IO-Link

- Compatible with all fieldbus and industrial ethernet networks (via IO-Link master).
- 3-wire connection.
- Easy maintenance thanks to the storage of parameters in the IO-Link master.



User communication interface

LECOM Manager

- PC control software, configuration, and diagnostic software for the LEMCOM series, dedicated to "vacuum applications".



Vacuum Manager App (NFC)

- Available on iOS and Android.
- Configuration and diagnosis of the GVMAX HD and CMS HD series.
- Uploading of operating data to the COVAL cloud.



WEB Server

- Embedded on the master modules of the LEMCOM series.
- Integrated into the commercial IO-Link master for the LEMAX IO/ GVMAX HD.
- Direct access to control, configuration, and diagnostic functions.



High resolution display

- LCD color display on GVMAX HD and CMS HD series.

Vacuum Pumps Overview

Vacuum Pump Range

5

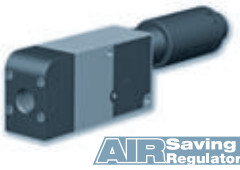
Micro Ejectors / Vacuum Cartridges		
VR 	<ul style="list-style-type: none"> ■ 5 models ■ Nozzle Ø: 0.5 ; 0.7 ; 0.9 ; 1 ; 1.2 ; 1.4mm ■ Suction flow rate: 7 to 64 NI/min ■ Optimum supply pressure: 5 bar ■ Weight between 20 and 45 g ■ Silencer option 	<ul style="list-style-type: none"> ■ Wide range ■ Very compact ■ Installed directly on the suction cups ■ Excellent mechanical resistance ■ Reduced gripping time ■ Blow-off option ■ Extended suction flow rate range ■ Silent operation ■ Adaptable to all industries
GVR 	<ul style="list-style-type: none"> ■ 2 models ■ Nozzle Ø: 0.9 ; 1 ; 1.2 ; 1.4 mm ■ Suction flow rate: 21 to 64 NI/min ■ Optimum supply pressure: 5 bar ■ Weight 45 g ■ Integrated silencer 	<ul style="list-style-type: none"> ■ Very compact ■ Installed directly on the suction cups ■ Excellent mechanical resistance ■ No clogging ■ Reduced gripping time ■ Blow-off option ■ Extended suction flow rate range ■ Silent operation ■ Adaptable to all industries
CVP 	<ul style="list-style-type: none"> ■ 2 sizes ■ Nozzle Ø: 1.2 ; 1.4 ; 1.6 ; 2.2 ; 2.7 mm ■ Suction flow rate: 41 to 215 NI/min ■ Optimum supply pressure: 5 to 5.5 bar ■ Weight between 6 and 23 g 	<ul style="list-style-type: none"> ■ Ultra-light and compact cartridge design allows for great flexibility and easy integration. ■ Vacuum technology: powerful single-stage Venturi that is dust resistant and maintenance-free. ■ Adaptable to all industries
CVPC 	<ul style="list-style-type: none"> ■ 2 sizes ■ Nozzle Ø: 1.2 ; 1.4 ; 1.6 ; 2.2 ; 2.7 mm ■ Suction flow rate: 41 to 215 NI/min ■ Optimum supply pressure: 5 to 5.5 bar ■ Weight: 22 g ■ Control indicator light ■ M8 connector 	<ul style="list-style-type: none"> ■ Ultra-light and compact cartridge design allows for great flexibility and easy integration. ■ Integrated pilot control solenoid valve that controls the compressed air in order to regulate vacuum, ensuring high reactivity and thus a quick response time, meeting the requirements of ultra-fast pick & place applications. ■ Vacuum technology: powerful single-stage Venturi that is dust resistant and maintenance-free. ■ Adaptable to all industries
CBP 	<ul style="list-style-type: none"> ■ Pilot solenoid valve 2/2-way ■ Nominal flow rate at 6 bar: 355 NI/min ■ Nominal diameter: 3 mm ■ Control indicator light ■ M8 connector 	<ul style="list-style-type: none"> ■ Ultra-light and compact cartridge design allows for great flexibility and easy integration ■ Electro-pneumatic control valve 2/2-way ■ Blow-off control valve ■ Single and multi-cartridge control valve.
Vacuum Pumps without control		
GVP 	<ul style="list-style-type: none"> ■ Simple vacuum pumps ■ Nozzle Ø: 1.2 ; 1.5 ; 2 ; 2.5 ; 3 mm ■ Suction flow rate: 45 to 450 NI/min ■ Optimum supply pressure: 4 bar ■ Integrated silencer 	<ul style="list-style-type: none"> ■ Modular design with interchangeable options ■ Compact ■ Optimized performance for handling all types of objects ■ Silent operation ■ No clogging ■ Adaptable to all industries
GEMP 	<ul style="list-style-type: none"> ■ Simple energy-saving vacuum pumps ■ Nozzle Ø: 1.2 ; 1.5 ; 2 ; 2.5 ; 3 mm ■ 2 vacuum levels: 60% and 85% ■ Suction flow rate: 72 to 385 NI/min ■ Integrated supply pressure regulator (ASR) ■ Integrated silencer 	<ul style="list-style-type: none"> ■ Very compact and light-weight ■ Exceptional energy savings thanks to automatic pressure regulation at 4 bar ■ Optimized performance for handling all types of objects ■ Silent operation ■ No clogging
GVEC 	<ul style="list-style-type: none"> ■ "Easy Clean" Vacuum Pumps ■ Nozzle Ø: 1.5 ; 2.5 ; 3 mm ■ Suction flow rate: 95 to 330 NI/min ■ Optimum supply pressure: 4 bar ■ Materials resistant to corrosion and compatible with food-processing sector 	<ul style="list-style-type: none"> ■ Very compact and light-weight ■ Ideal for applications needs frequent cleaning ■ Use in washing or splashing zones ■ No clogging

Vacuum Pumps Overview

Vacuum Pump Range

Intelligent Vacuum Pumps

LEMP



- Mini Vacuum Pumps without control with ASR (Air Saving Regulator)
- Nozzle Ø: 1; 1.2; 1.4 mm
- 2 vacuum levels: 60% and 85%
- Suction flow rate up to 92 NI/min
- Integrated pressure regulator (ASR)
- With or without vacuum switch
- M8 connections
- Stand-alone or island module

- For airtight and porous objects
- Ultra compact and lightweight
- Control panel for monitoring and adjustment
- Energy savings in all networks > 4 bar
- Reduced wiring
- Reduced installation time
- Adaptable to all industries

LEM



- Integrated Mini Vacuum Pumps with ASR (Air Saving regulator)
- Nozzle Ø: 1; 1.2; 1.4 mm
- 2 vacuum levels: 60% and 85%
- Suction flow rate up to 92 NI/min
- Integrated pressure regulator (ASR)
- All required functions integrated internally
- M8 connections
- Stand-alone or island module

- For airtight and porous objects
- Ultra compact and lightweight
- Control panel for monitoring and adjustment
- Energy savings in all networks > 4 bar
- Reduced wiring
- Reduced installation time
- Adaptable to all industries

LEMAX



- Integrated Mini Vacuum Pumps with ASC (Air Saving Control)
- Nozzle Ø: 1; 1.2; 1.4 mm
- Vacuum level: 85%
- Suction flow rate up to 70 NI/min
- Integrated pressure regulator (ASR)
- Integrated vacuum regulation (ASC)
- All required functions integrated internally
- M8 connections
- Stand-alone or island module

- For sealed or slightly porous parts
- Ultra compact and lightweight
- Control panel for monitoring and adjustment
- ASC = 75% to 90% energy savings
- Reduced wiring
- Reduced installation time
- Adaptable to all industries

LEMAX IO



- Mini Vacuum Pumps Communicating via Industrial Field Bus
- Nozzle Ø: 1; 1.2; 1.4 mm
- Vacuum level: 85%
- Suction flow rate up to 70 NI/min
- Integrated pressure regulator (ASR)
- Integrated vacuum regulation (ASC)
- IO-Link
- M8 connections
- Stand-alone or island module

- For sealed or slightly porous parts
- Ultra compact and lightweight
- Settings and diagnosis by remote monitoring.
- ASC = 75% to 90% energy savings
- Easy installation and operation thanks to the IO-Link communication interface
- Adaptable to all industries

LEMCOM



- Mini Vacuum Pumps Communicating via Industrial Field Bus
- Nozzle Ø: 1; 1.2; 1.4 mm
- 2 vacuum levels: 60% and 85%
- Suction flow rate up to 92 NI/min
- Integrated pressure regulator (ASR)
- Integrated vacuum regulation (ASC)
- Field bus: PROFINET, EtherNet/IP™
- M8 connections
- Stand-alone or island module

- For sealed or slightly porous parts
- Ultra compact and lightweight
- Settings and diagnosis by remote monitoring.
- ASC = 75% to 90% energy savings
- Reduced wiring
- Reduced installation time
- Adaptable to all industries

LEM+



- Compact High Flow Vacuum Pumps with ASR (Air Saving Regulator)
- Nozzle Ø: 2; 2.5 mm
- 2 vacuum levels: 60% and 85%
- Suction flow rate up to 275 NI/min
- Integrated pressure regulator (ASR)
- All required functions integrated internally
- M12 connections

- For airtight and porous objects
- Compact and lightweight
- Control panel for monitoring and adjustment
- Energy savings in all networks > 4 bars
- Reduced wiring
- Reduced installation time
- Adaptable to all industries

Vacuum Pumps Overview

Vacuum Pump Range

5

Intelligent Vacuum Pumps

LEMEX+



- Compact High Flow Vacuum Pumps with ASC (Air Saving Control)
- Nozzle Ø: 2 ; 2.5 mm
- Vacuum level: 85%
- Suction flow rate up to 200 NI/min
- Integrated pressure regulator (ASR)
- Integrated vacuum regulation (ASC)
- All required functions integrated internally
- M12 connections

- For sealed or slightly porous parts
- Compact and lightweight
- Control panel for monitoring and adjustment
- ASC = 75% to 90% energy savings
- Reduced wiring
- Reduced installation time
- Adaptable to all industries

GVMAX HD



NFC)))

IO-Link

- Heavy Duty Communicating Vacuum Pumps
- Nozzle Ø: 2.5 ; 3 mm
- Vacuum level: 85%
- Suction flow rate up to 230 NI/min
- Integrated vacuum regulation (ASC)
- Standard In/Out (SIO) and IO-Link
- NFC
- M12 connections
- Standalone vacuum pumps or in island assemblies

- For sealed or slightly porous parts
- High visibility color display with clear multi-lingual messages and straightforward settings menu
- ASC = 75% to 90% energy savings
- Easy installation and operation thanks to the IO-Link communication interface
- Easy set up made possible by NFC technology and COVAL Vacuum Manager mobile application
- Adaptable to all industries

CMS HD



NFC))) IO-Link

- Heavy Duty Communicating Vacuum Pumps
- 3 powerful suction flow rates from 700 NI/min to 1600 NI/min
- Vacuum level: 80%
- With or without vacuum and blow-off control
- M12 connections
- Digital inputs/outputs mode (SIO)/ IO-Link
- NFC
- 3 exhaust configurations

- For airtight and porous objects
- High visibility color display with clear multi-lingual messages and straightforward settings menu
- Easy installation and operation thanks to the IO-Link communication interface
- Easy set up made possible by NFC technology and COVAL Vacuum Manager mobile application
- Adaptable to all industries

Air Amplifiers

M--C



- Operating principle based on the COANDA effect
- Bore diameter (Ø): 6, 10, 20, 30, 40 mm
- Flow rate: between 200 and 5000 NI/min depending on the supply pressure (between 1.5 and 6 bar)
- Body material: aluminum

- Recommended for gripping light-weight, porous products: foam, carpet, cakes, leather, etc.
- Transport of powdery materials: powders, granules, etc.
- Transporting small, light-weight objects: paper clips, rice, coffee, etc.
- Smoke evacuation, depressurizing chambers

MD



- Operating principle based on the COANDA effect
- Bore diameter (Ø): 26,6 and 38,1 mm
- Flow rate: between 2015 and 4370 NI/min depending on the supply pressure (between 3 and 5 bar)
- Body material: aluminum

- Recommended for gripping lightweight, porous products: foam, carpet, cakes, leather, etc.
- Transport of powdery materials: powders, granules, etc.
- Transporting small, lightweight objects: paper clips, rice, coffee, etc.
- Smoke evacuation, depressurizing chambers

TVM



- Pipes for Air Amplifiers
- Flexible polyurethane hose with steel spiral reinforcement.
- 4 sizes available: Ø 25, 40, 50 and 60 mm
- Anti-static properties according to DIN 53486

- Commonly used with COVAL air amplifiers (M--C series)
- High resistance to abrasion, cutting lubricant and UV rays

Vacuum Pumps Overview

Evacuation Time

Evacuation time in seconds per liter

% vacuum	10 %	20 %	30 %	40 %	50 %	60 %	70 %	80 %	85 %
VR05	0.92	1.96	3.18	4.63	6.38	8.79	12.17	18.96	27.39
VR07	0.46	0.98	1.58	2.28	3.13	4.27	5.8	8.55	11.01
VR09	0.31	0.65	1.05	1.52	2.09	2.85	3.87	5.7	7.34
VR10	0.24	0.51	0.82	1.18	1.62	2.21	3.01	4.43	5.71
GVR09S	0.31	0.65	1.05	1.52	2.09	2.85	3.88	5.7	7.34
GVR10	0.24	0.51	0.82	1.18	1.62	2.21	3.01	4.43	5.71
VR12	0.14	0.3	0.49	0.71	0.97	1.33	1.81	2.66	3.42
GVR12	0.14	0.3	0.49	0.71	0.97	1.33	1.81	2.66	3.42
VR14	0.1	0.21	0.34	0.5	0.68	0.93	1.27	1.85	2.44
GVR14	0.1	0.21	0.34	0.5	0.68	0.93	1.27	1.85	2.44
GVP12N	0.14	0.3	0.49	0.71	0.97	1.33	1.81	2.66	3.42
GVP15N	0.09	0.20	0.32	0.46	0.63	0.85	1.16	1.71	2.20
GVP20N	0.06	0.12	0.19	0.28	0.38	0.52	0.71	1.04	2.13
GVP25N	0.03	0.07	0.11	0.16	0.22	0.30	0.41	0.60	0.77
GVP30N	0.02	0.05	0.08	0.12	0.17	0.23	0.31	0.45	0.58

% vacuum	10 %	20 %	30 %	40 %	50 %	60 %	70 %
GVP12T	0.1	0.22	0.37	0.55	0.78	1.16	1.92
GVP15T, GVEC15T	0.07	0.15	0.24	0.36	0.52	0.77	1.27
GVP20T	0.04	0.09	0.14	0.22	0.31	0.46	0.76
GVP25T, GVEC25T	0.03	0.06	0.1	0.14	0.21	0.3	0.5
GVP30T, GVEC30T	0.02	0.04	0.07	0.1	0.15	0.22	0.37

% vacuum	10 %	20 %	30 %	35 %	40 %	45 %
GVP12X	0.05	0.11	0.22	0.33	0.62	0.62
GVP15X	0.04	0.09	0.15	0.2	0.27	0.39
GVP20X	0.03	0.06	0.11	0.15	0.19	0.28
GVP25X	0.02	0.04	0.08	0.1	0.14	0.19
GVP30X	0.01	0.03	0.06	0.08	0.11	0.15

% vacuum	10 %	20 %	30 %	40 %	50 %	60 %	70 %	80 %	85 %
GEMP60x12	0.09	0.2	0.35	0.55	0.9	-	-	-	-
GEMP60x15	0.06	0.14	0.23	0.36	0.59	-	-	-	-
GEMP60x20	0.04	0.08	0.13	0.21	0.34	-	-	-	-
GEMP60x25	0.03	0.05	0.09	0.14	0.24	-	-	-	-
GEMP60x30	0.01	0.04	0.07	0.10	0.17	-	-	-	-
GEMP90x12	0.13	0.27	0.44	0.64	0.88	1.19	1.62	2.37	3.12
GEMP90x15	0.09	0.18	0.29	0.42	0.58	0.79	1.08	1.59	2.08
GEMP90x20	0.05	0.11	0.18	0.25	0.35	0.46	0.65	0.95	1.25
GEMP90x25	0.03	0.07	0.11	0.16	0.22	0.3	0.41	0.59	0.78
GEMP90x30	0.03	0.06	0.09	0.13	0.18	0.24	0.33	0.48	0.64

% vacuum	30 %	35 %	40 %	45 %	50 %	55 %
LEM/LEMP 60X10	0.66	0.83	1.04	1.31	1.70	2.35
LEM/LEMP 60X12	0.41	0.52	0.66	0.83	1.07	1.49
LEM/LEMP 60X14	0.27	0.34	0.43	0.54	0.70	0.97
LEM60X20	-	0.16	-	0.27	-	0.42
LEM60X25	-	0.11	-	0.18	-	0.31

Vacuum Pumps Overview

Evacuation Time and Weight of Vacuum Pumps

Evacuation time in seconds per liter (cont.)

% vacuum	55 %	60 %	65 %	70 %	75 %	80 %
LEM/LEMP/LEMAX/LEMATIO 90X10	1.76	2.04	2.38	2.80	3.33	4.09
LEM/LEMP/LEMAX/LEMATIO 90X12	1.13	1.31	1.53	1.80	2.15	2.64
LEM/LEMP/LEMAX/LEMATIO 90X14	0.73	0.85	0.99	1.16	1.38	1.70
LEM/LEMAX 90X20	0.38	-	0.55	-	0.80	-
LEM/LEMAX 90X25	0.26	-	0.35	-	0.50	-

% vacuum	45 %	55 %	65 %	75 %
GVMAXHD90X25	0.17	0.24	0.35	0.52
GVMAXHD90X30	0.15	0.20	0.27	0.42

% vacuum	45 %	55 %	65 %	75 %
CMSHD90X50	0.10	0.18	0.30	0.60
CMSHD90X100	0.07	0.10	0.16	0.30
CMSHD90X150	0.05	0.08	0.13	0.24

5

Weight of micro/mini-ejectors in grams

Model	Nozzle size (mm)							
	0.5	0.7	0.9	1.0	1.2	1.4	1.5	2.0
VR	20.7	20.5	20.2	45.4	45.4	45.4	-	-
GVR	20.7	20.5	20.2	45.4	45.4	45.4	-	-

Weight of vacuum pumps in grams

Model	Nozzle size (mm)				
	1.2	1.5	2.0	2.5	3.0
GVEC	-	33	-	139	159
GVP	100	110	160	180	265
GEMP	maximum weight 265				

Model	Nozzle size (mm)				
	1.0	1.2	1.4	2.0	2.5
LEMP	90 to 110 g, depending on the model.			-	-
LEM	90 to 120 g, depending on the model.			-	-
LEM+	-	-	-	410 to 460 g, depending on the model.	
LEMAX	100 to 130 g, depending on the model.			-	-
LEMATIO	130 g			-	-
LEMAX+	-	-	-	410 to 460 g, depending on the model.	
LEMCOM	150 g			-	-

Model	Nozzle size (mm)				
	1.2	1.5	2.0	2.5	3.0
GVMAX HD	-	-	-	-	870 g

Model	Without control	With control
CMSHD--50/100	645 g	890 g
CMSHD--150	1330 g	1575 g

Micro Ejectors / Vacuum Cartridges

Chapter 6

VR



Heavy-duty in-Line Ejectors

- 5 models
- Nozzle Ø:
0.5 ; 0.7 ; 0.9 ; 1 ; 1.2 ; 1.4 mm
- Suction flow rate: 7 to 64 NI/min
- Optimum supply pressure: 5 bar
- Weight between 20 and 45 g
- Silencer option
- Wide range
- Very compact
- Direct installation on suction cups
- Excellent mechanical resistance
- Reduced gripping time
- Blow-off option
- Extended suction flow rate range
- Silent operation
- Adaptable to all industries

P 6/2

GVR



Heavy-duty in-Line Ejectors

- 2 models
- Nozzle Ø:
0.9 ; 1 ; 1.2 ; 1.4 mm
- Suction flow rate:
21 to 64 NI/min
- Optimum supply pressure: 5 bar
- Weight: 45 g
- Integrated silencer
- Very compact
- Direct installation on suction cups
- Excellent mechanical resistance
- No clogging
- Reduced gripping time
- Blow-off option
- Extended suction flow rate range
- Silent operation
- Adaptable to all industries

P 6/6

CVP



Vacuum Cartridges

- 2 sizes
- Nozzle Ø:
1.2 ; 1.4 ; 1.6 ; 2.2 ; 2.7 mm
- Suction flow rate:
41 to 215 NI/min
- Optimum supply pressure:
5 to 5.5 bar
- Weight between 6 and 23 g
- Ultra-light and compact cartridge design allows for great flexibility and easy integration.
- Vacuum technology: powerful single-stage Venturi that is dust resistant and maintenance-free.
- Adaptable to all industries

P 6/8

CVPC



Controlled Vacuum Cartridges

- 2 sizes
- Nozzle Ø:
1.2 ; 1.4 ; 1.6 ; 2.2 ; 2.7 mm
- Suction flow rate:
41 to 215 NI/min
- Optimum supply pressure:
5 to 5.5 bar
- Weight: 22 g
- Control indicator light
- M8 connector
- Ultra-light and compact cartridge design allows for great flexibility and easy integration.
- Integrated pilot control solenoid valve that controls the compressed air in order to regulate vacuum, ensuring high reactivity and thus a quick response time, meeting the requirements of ultra-fast pick & place applications.
- Vacuum technology: powerful single-stage Venturi that is dust resistant and maintenance-free.
- Adaptable to all industries

P 6/12

CBP



Pilot Control Cartridge

- Pilot solenoid valve 2/2-way
- Nominal flow rate at 6 bar:
355 NI/min
- Nominal diameter: 3 mm
- Control indicator light
- M8 connector
- Ultra-light and compact cartridge design allows for great flexibility and easy integration
- Electro-pneumatic control valve 2/2-way.
- Blow-off control valve
- Single and multi-cartridge control valve.

P 6/16

VR 05, 07, 09

Heavy-duty In-line Ejectors



Industry-specific applications

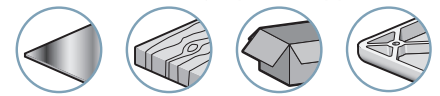

The main advantage of the VR series in-line ejectors is that they can be mounted directly on the suction cup, which simplifies plumbing.

By integrating the ejector on the suction cup, we obtain a localized vacuum and, therefore, the possibility of obtaining multiple independent grips, even in the absence of objects.

It is also possible to supply vacuum to two or more suction cups using a G1/8" or G1/4" T-shaped fitting.

Advantages

- Wide range
- Adaptable to all industries
- Lightweight and compact
- Reduced gripping time
- Direct installation on suction cups
- Excellent mechanical resistance
- Blow-off option
- Extended range of suction flow rates
- No clogging
- Silent operation

Characteristics

Model	Ø Nozzle	Air consumed (NI/min)	Maximum vacuum (%)	Air drawn in (NI/min)	At air pressure (bar)
VR 05	0.5	12	87	7	5
VR 07	0.7	21	90	14	5
VR 09	0.9	36	90	21	5

Note: All dimensions are in mm

Evacuation Time in Seconds per Liter

% vacuum	10 %	20 %	30 %	40 %	50 %	60 %	70 %	80 %	85 %
VR05	0.92	1.96	3.18	4.63	6.38	8.79	12.17	18.96	27.39
VR07	0.46	0.98	1.58	2.28	3.13	4.27	5.8	8.55	11.01
VR09	0.31	0.65	1.05	1.52	2.09	2.85	3.87	5.7	7.34

Specifications

Supply	Non-lubricated filtered air, pressure 2 to 6 bar
Optimum operating pressure	5 bar
Weight	20 g
Material	2017A - Cu Zn
Temperature	0 to 80 °C.

When ordering, please specify:
Model + Nozzle diameter + Vacuum outlet
 e.g.: VR07M6

1: Model	2: Ø Nozzle	3: Vacuum outlet
VR	05	Ø 0.5 mm
	07	Ø 0.7 mm
	09	Ø 0.9 mm
	M6	M6 Female
	M18	G1/8" Male
	M14	G1/4" Male
F18	G1/8" Female	
F14	G1/4" Female	

Additional Information

Mounting on spring systems

- Spring system, series TS3, available strokes: 10, 30, 50, 70mm, page 4/4.
- TSOP-TSOG series anti-rotation spring system, pages 4/6 and 4/7.
- Ball-joint systems, IMU series, page 4/12.

Customized on request

- Alternate material option: stainless steel or plastic, based on specifications.
- Special characteristics such as suction flow rate or vacuum level.
- On request for the F18 model, M5 ancillary vacuum fitting for connection of a vacuum switch.

New function

- Silencer option: (ref. SILGV10M5F)
- Vacuum or blow-off switch, on request.

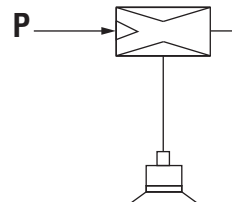

VR 05, 07, 09

Heavy-duty In-line Ejectors

Dimensions and Data Curves



Dimensions

- (1) G1/4"-F C.A. inlet, depth 10 mm
- (2) M6-F vacuum outlet, depth 6 mm
- (3) Example of suction cup
- (4) Silencer
- (5) G1/8"-F vacuum outlet, depth 7.5 mm
- (6) G1/4"-F vacuum outlet, depth 10 mm
- (7) Compressed air
- (8) Exhaust
- (9) Hexagonal nut, 14 across flats
- (10) Hexagonal nut, 19 across flats

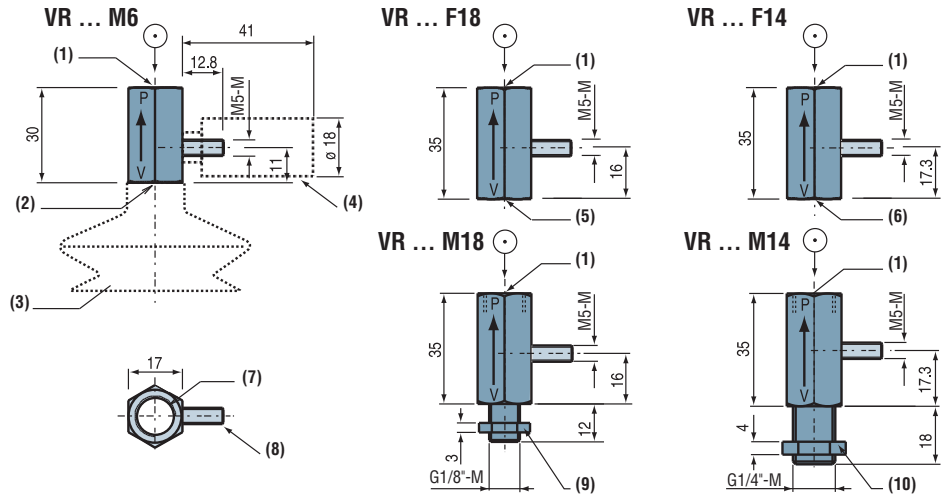

Note: All dimensions are in mm

Data Curves

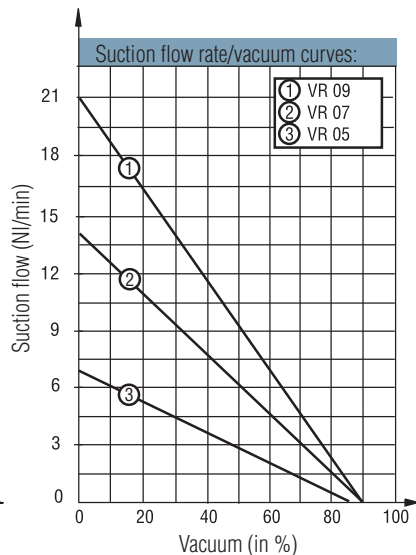
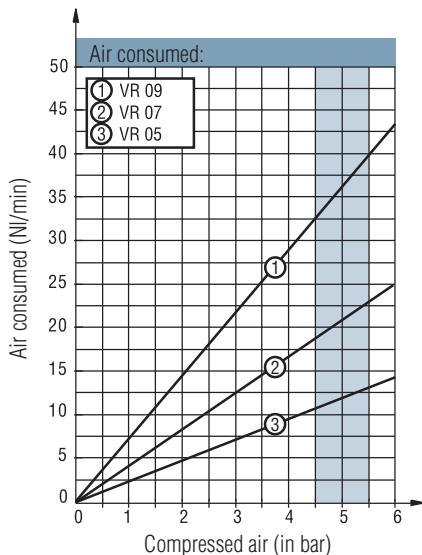
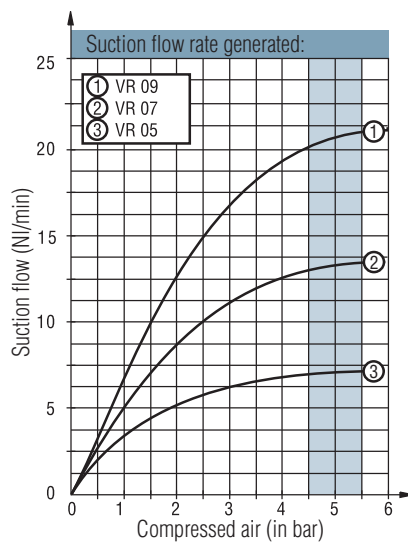
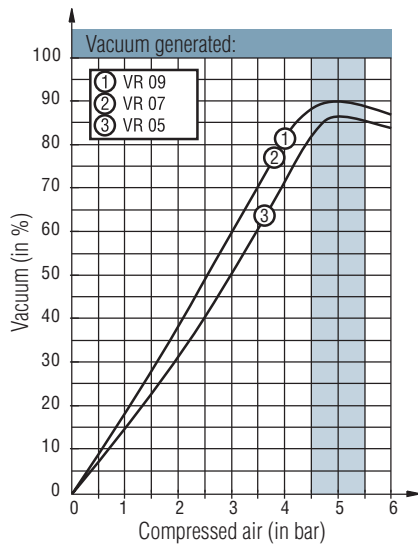

VR 10, 12, 14

Ejector Fittings



Based on the same principle as the VR 05, 07, 09, the main advantage of the VR 10, 12, 14 series is that they can be mounted directly on larger suction cups due their optimum technical characteristics.

The aluminum design guarantees:

- Excellent mechanical resistance
- Lightweight
- Ideal for miscellaneous gripping.

Industry-specific applications

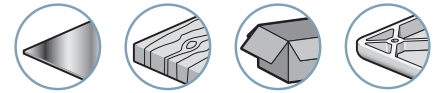

Advantages

- Wide range
- Adaptable to all industries
- Lightweight and compact
- Reduced gripping time
- Direct installation on suction cups
- Excellent mechanical resistance
- Blow-off option
- Extended range of suction flow rates
- No clogging
- Silent operation

Characteristics

Model	Ø nozzle	Air consumed (Nl/min)	Maximum vacuum (%)	Air drawn in (Nl/min)	At air pressure (bar)
VR 10	1	44	90	27	5
VR 12	1.2	67	90	45	5
VR 14	1.4	108	90	64	5

Note: All dimensions are in mm

Evacuation Time in Seconds per Liter

% vacuum	10 %	20 %	30 %	40 %	50 %	60 %	70 %	80 %	85 %
VR 10	0.24	0.51	0.82	1.18	1.62	2.21	3.01	4.43	5.71
VR 12	0.14	0.3	0.49	0.71	0.97	1.33	1.81	2.66	3.42
VR 14	0.1	0.21	0.34	0.5	0.68	0.93	1.27	1.85	2.44

Specifications

Supply	Non-lubricated filtered air, pressure 2 to 6 bar
Optimum operating pressure	5 bar
Weight	50 g
Material	2017A - Cu Zn
Temperature	0 to 80 °C.

Additional Information

As standard

- New functions: vacuum switch or blow-off switch with or without silencer (SILGV 10).

Optional

- MS2M5 or MS4M5 blow-off valves with no-return valve on vacuum (see page 11/4).

Special

- Coval offers the product best adapted to your needs based on your specifications, and advises you according to your applications (material, shape, special technical characteristics).

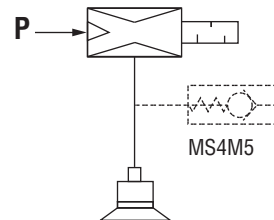

6 VR 10, 12, 14



When ordering, please specify:
Model + Nozzle diameter + Vacuum outlet + Silencer
 e.g.: VR12M14S

1: Model	2: Ø Nozzle	3: Vacuum outlet	4: Silencer
VR	10 Ø 1 mm 12 Ø 1.2 mm 14 Ø 1.4 mm	M14 G1/4" Male	S SILGV 10 K SILK 18 C ⁽¹⁾

(1) SILK 18 C through-type silencer dimensions, see page 11/11.

VR 10, 12, 14

Ejector Fittings

Dimensions and Data Curves



Dimensions

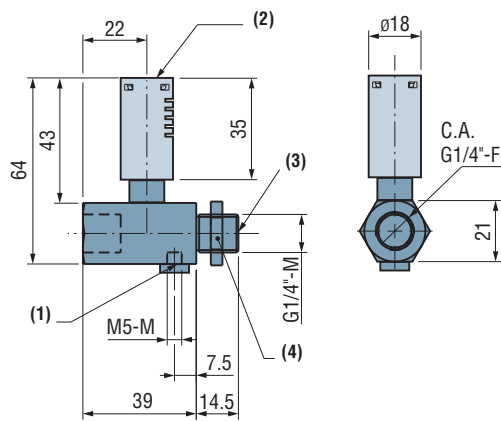

VR + MS4M5 version

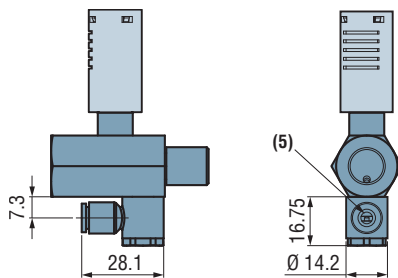

- (1) Blow-off or vacuum switch
- (2) Silencer
- (3) Vacuum
- (4) Hexagonal nut, 19 across flats
- (5) Push fitting, external $\varnothing 6$

Data Curves

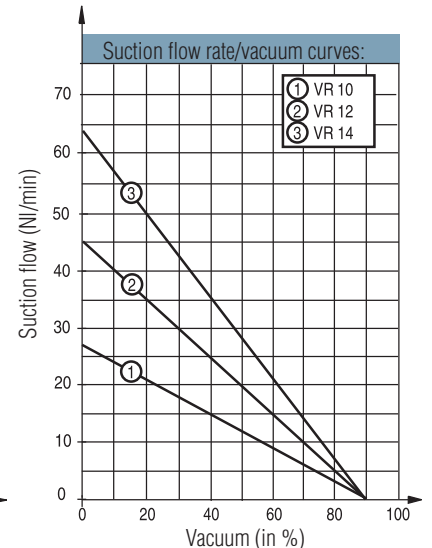
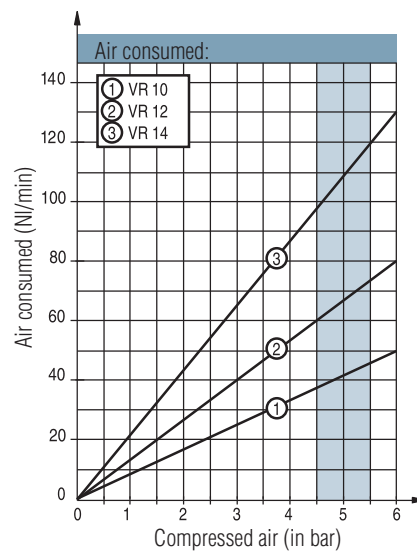
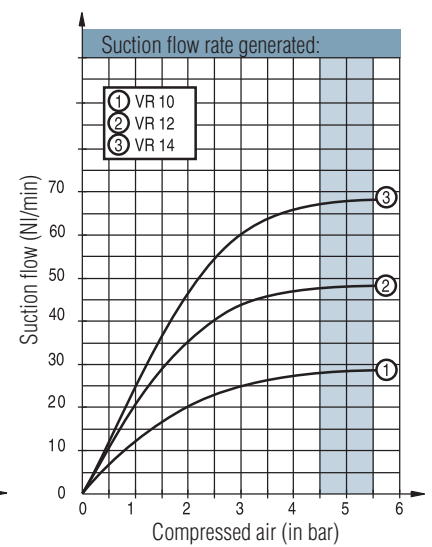
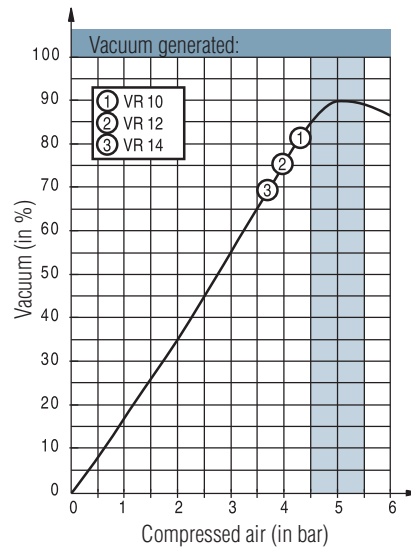

Note: All dimensions are in mm

GVR 09, 10, 12, 14 Micro Ejectors



Industry-specific applications

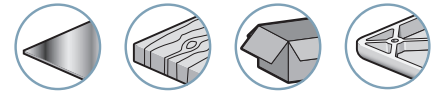

The GVR range is designed for an industrial environment:

- Compact
- Lightweight
- Optimized technical characteristics
- Pollution-resistant with its through-type silencer (SILK 18C)
- Easily integrated onto vacuum gripper
- Pass-through mounting using M10 screws (GVR09)

Advantages

- Adaptable to all industries
- Lightweight and compact
- Reduced gripping time
- Direct installation on suction cups
- Excellent mechanical resistance
- Blow-off option
- No clogging
- Silent operation

Characteristics

Models	Ø nozzle	Air consumed (NI/min)	Maximum vacuum (%)	Air drawn in (NI/min)	At air pressure (bar)
GVR 09	0.9	36	85	21	5
GVR 10	1	44	85	27	5
GVR 12	1.2	67	85	45	5
GVR 14	1.4	108	85	64	5

Note: All dimensions are in mm

Evacuation Time in Seconds per Liter

% vacuum	10 %	20 %	30 %	40 %	50 %	60 %	70 %	80 %	85 %
GVR 09	0.31	0.65	1.05	1.52	2.09	2.85	3.87	5.7	7.34
GVR 10	0.24	0.51	0.82	1.18	1.62	2.21	3.01	4.43	5.71
GVR 12	0.14	0.3	0.49	0.71	0.97	1.33	1.81	2.66	3.42
GVR 14	0.1	0.21	0.34	0.5	0.68	0.93	1.27	1.85	2.44

Specifications

Supply	Non-lubricated filtered air, pressure 2 to 6 bar
Optimum operating pressure	5 bar
Weight	40 g
Material	2017A - Cu Zn
Temperature	0 to 80 °C.

Additional Information

As standard

- Vacuum switch or blow-off switch with SILGV 10. SILK18C silencer (through-type) on request.

Optional

- MS2M5 or MS4M5 blow-off valves with non-return valve on vacuum (see page 11/4).

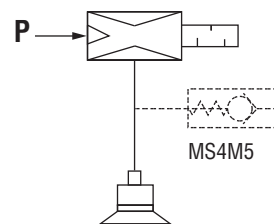

6
GVR 09, 10, 12, 14



When ordering, please specify:
Model + Nozzle diameter + Silencer
e.g.: GVR12K

1: Model	2: Ø nozzle	3: Silencer	
GVR	09	Ø 0.9 mm	- Without
	10	Ø 1 mm	S SILGV 10
	12	Ø 1.2 mm	K SILK 18 C ⁽¹⁾
	14	Ø 1.4 mm	

(1) SILK 18 C through-type silencer dimensions, see page 11/11.

GVR 09, 10, 12, 14

Micro Ejectors

Dimensions and Data Curves



Dimensions

GVR 10, 12, 14 + MS4M5

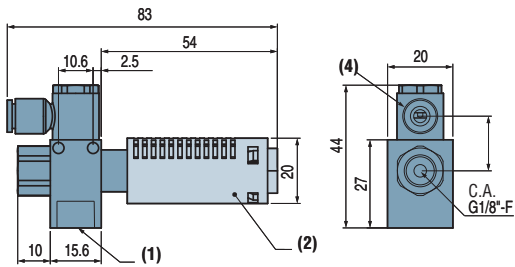

GVR 10, 12, 14

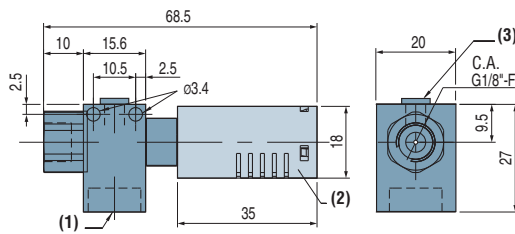

GVR 09

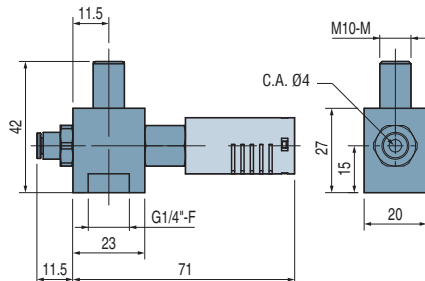

- (1) Vacuum G1/4"-F
- (2) Silencer
- (3) M5-F plug for vacuum switch
- (4) Push fitting, outside \varnothing 6

Data Curves

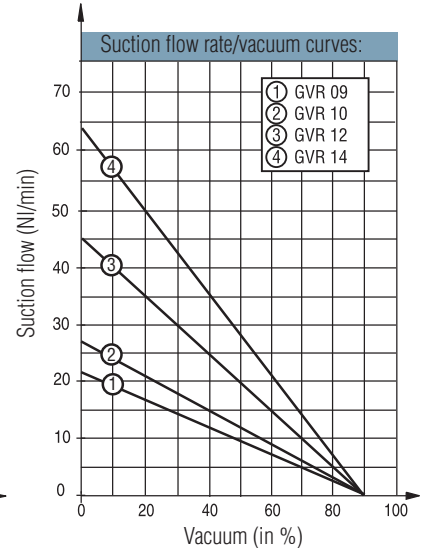
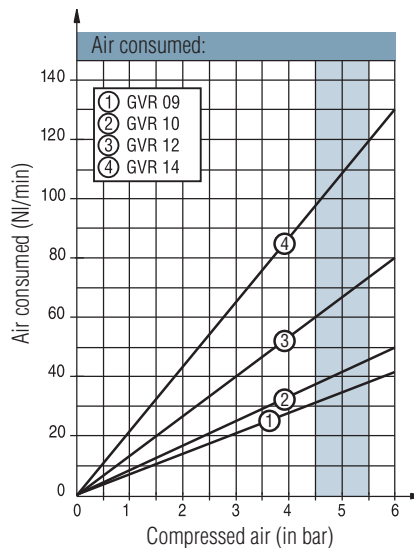
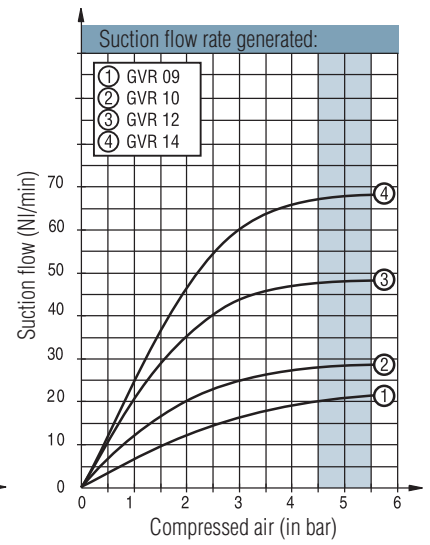
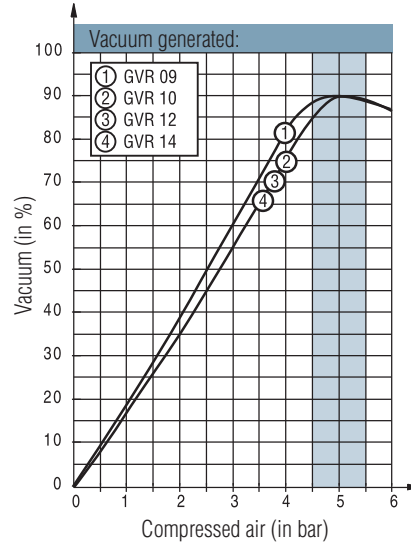

Note: All dimensions are in mm

CVP

Vacuum Cartridges

General Information

Owing to their compact size and light weight, the **CVP** Series vacuum cartridges can be used to easily install a simple and reliable vacuum generation system as close to the application as possible.

They meet the flexibility, customization and performance needs of machine manufacturers and integrators of robotic solutions, who wish to easily design flexible, modular and efficient gripping tools.

CVP Series vacuum cartridges are suitable for a broad variety of applications and are available in different sizes and suction capacities:

- Size 1: nozzle dia. 1.2, 1.4 and 1.6 mm generating a suction flow rate ranging from 41 to 90 NI/min. Max. vacuum 85%.
- Size 2: nozzle dia. 2.2 and 2.7 mm generating a suction flow rate ranging from 160 to 215 NI/min. Max. vacuum 85%.

Advantages

- Ultra-light and compact cartridge design allows for great flexibility and easy integration.
- Vacuum technology: powerful single-stage Venturi that is dust resistant and maintenance-free.



Industry-specific applications

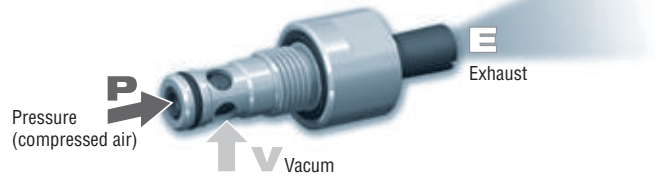
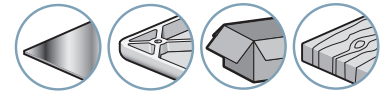

SIZE 1
Nozzle dia. 1.2, 1.4 or 1.6 mm

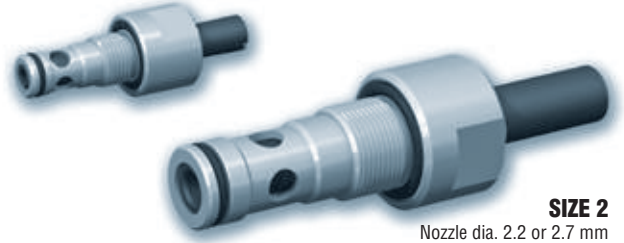

SIZE 2
Nozzle dia. 2.2 or 2.7 mm

Compact integration

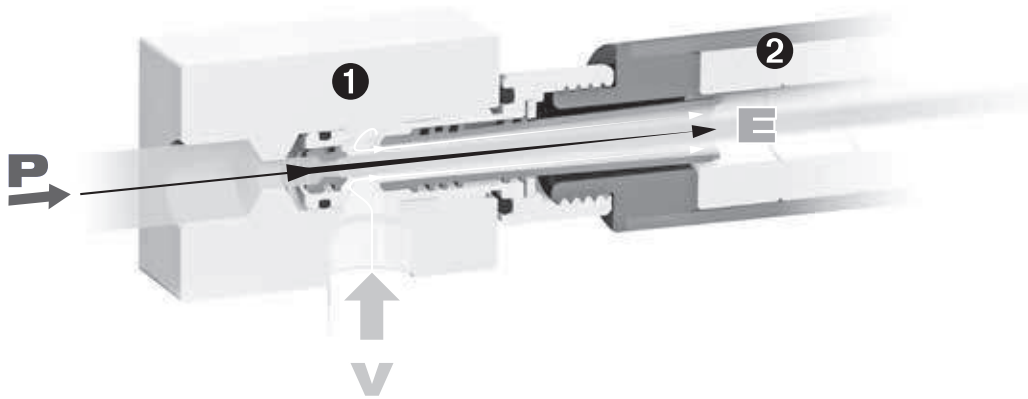

① Single-stage Venturi (nozzle + mixer system) ② Option: non-clogging through-type silencer

The CVP Series vacuum cartridges include a single-stage Venturi that uses compressed air to generate a powerful vacuum, thus guaranteeing short evacuation times.

The single-stage technology, consisting of a nozzle and a mixer, works without any moving parts, is dust resistant and maintenance-free.

CVP

Vacuum Cartridges

Implementation, Applications



Implementation

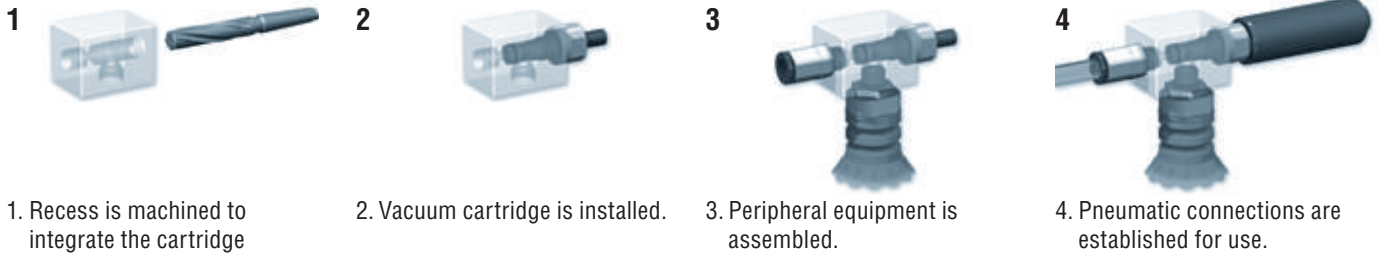

1. Recess is machined to integrate the cartridge

2. Vacuum cartridge is installed.

3. Peripheral equipment is assembled.

4. Pneumatic connections are established for use.



You will find the 3D files of the cartridges as well as the specifications of the machining operations to be carried out on our website www.coval.com

Application examples

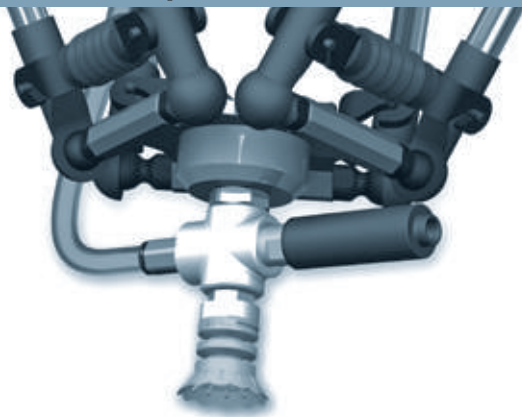

- 1 CVP series vacuum cartridge, with silencer
- 1 FPC series FlowPack suction cup



- 2 CVP series vacuum cartridges
- 2 VSAJ series soft and flexible suction cups

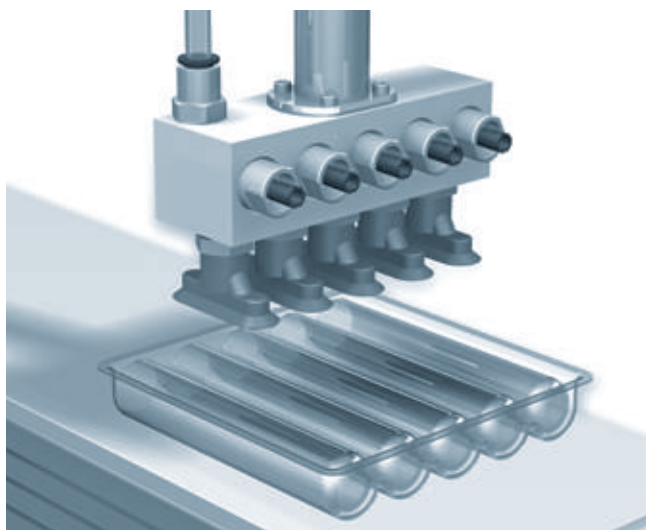

- 5 CVP series vacuum cartridges
- 5 VPO series oblong suction cups

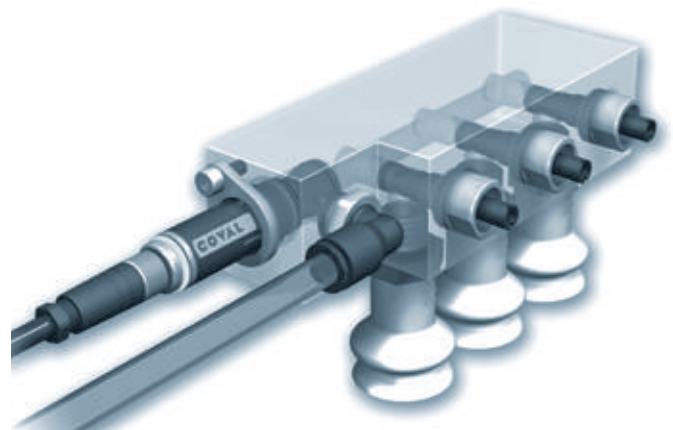

- 1 CBP series multi-cartridge control valve
- 3 CVP series vacuum cartridges
- 3 MVS series soft and flexible suction cups

CVP 6

CVP

Vacuum Cartridges

Technical and Performance Data



Characteristics

Model	Ø nozzle (mm)	Air consumed (NI/min)	Maximum vacuum (%)	Air drawn in (NI/min)	At optimal air pressure (bar)
CVP90x12	1.2	70	85	41	5 to 5.5
CVP90x14	1.4	115	85	70	5 to 5.5
CVP90x16	1.6	135	85	90	5 to 5.5
CVP90x22	2.2	260	85	160	5 to 5.5
CVP90x27	2.7	355	85	215	5 to 5.5

Evacuation time in seconds per liter

% vacuum	20	30	40	50	60	70	80
CVP90x12	0.31	0.53	0.83	1.25	1.91	3.23	6.14
CVP90x14	0.21	0.35	0.55	0.83	1.27	2.14	4.16
CVP90x16	0.15	0.25	0.38	0.57	0.83	1.35	2.63
CVP90x22	0.07	0.11	0.17	0.25	0.37	0.58	1.07
CVP90x27	0.05	0.08	0.12	0.18	0.26	0.44	0.8

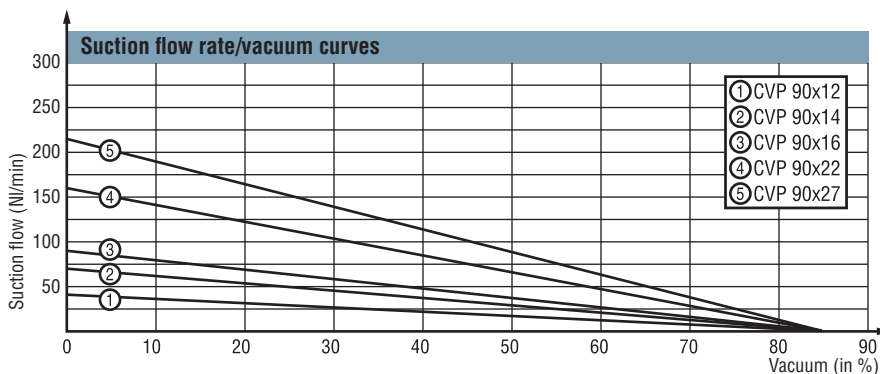
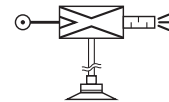
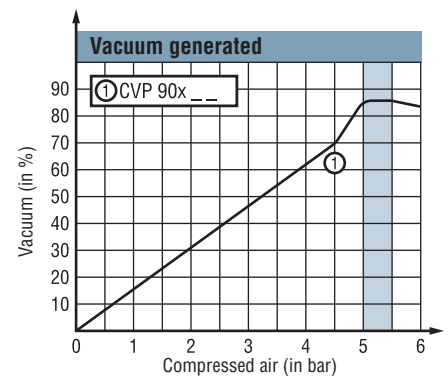
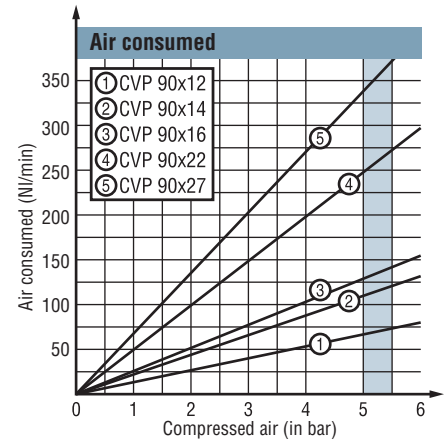

CVP 6

Dimensions

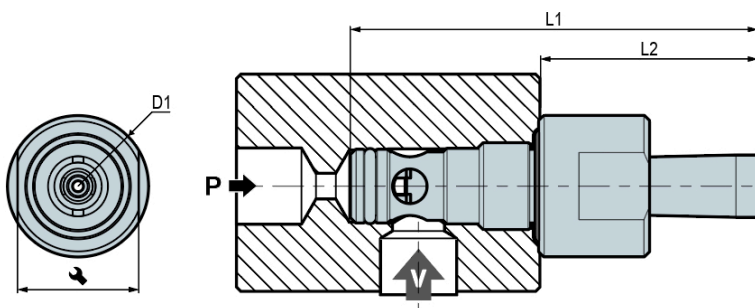

Model	D1	L1	L2	⚙️
CVP90X12	16	34.2	12.5	14
CVP90X14	16	41.1	19.4	14
CVP90X16	16	46.6	24.9	14
CVP90X22	25	73.4	32.9	22
CVP90X27	25	85.3	44.8	22

Note: All dimensions are in mm

Overall characteristics

- C.A. supply 5µ filtered, non-lubricated air relevant to standard ISO 8573-1:2010 [4:5:4].
- Operating pressure: 4.5 to 7 bar. (Optimal at 5 to 5.5 bar.)
- Max. vacuum: 85%.
- Suction flow rate: 41 to 215 NI/min depending on model.
- Air consumption: 70 to 355 NI/min depending on model.
- Operating temperature: from 0 to 50 °C.
- Weight : • size 1 : 6 g
• size 2 : 23 g.
- Materials : PA 6-6 15 % GF, aluminum, NBR.
- Noise level with silencer (option K):
 - CVP90X12K: 54 dBA
 - CVP90X14K: 59 dBA
 - CVP90X16K: 64 dBA
 - CVP90X22K: 67 dBA
 - CVP90X27K: 75 dBA

CVP

Vacuum Cartridges

Ordering, Accessories



To place an order

	CVP	90	X		12		K
	VACUUM LEVEL				NOZZLE DIAMETER		THROUGH-TYPE SILENCER
	85% max. vacuum	90			1.2 mm nozzle Ø	12	Without
					1.4 mm nozzle Ø	14	K With silencer
					1.6 mm nozzle Ø	16	
					2.2 mm nozzle Ø	22	
					2.7 mm nozzle Ø	27	

Through-type silencers - option K

- Lateral noise absorption on sound-absorbing material.
- Unrestricted exhaust without pressure loss or clogging.
- Average sound attenuation of 20 dBA.

→ Silencer for **CVP size 1**
(CVP90X12K/CVP90X14K/CVP90X16K)

- **G1/4"-M** silencer
 - Materials:- aluminum thread
 - PA6 tube, 30% GF

→ Silencer for **CVP size 2**
(CVP90X22K/CVP90X27K)

- **G1/2"-M** silencer
 - Material: - polycarbonate, 30% GF

Model	ØA	B	ØC	Weight (g)
Silencer for size 1	20	68	G1/4"-M	25
Silencer for size 2	30	121	G1/2"-M	92

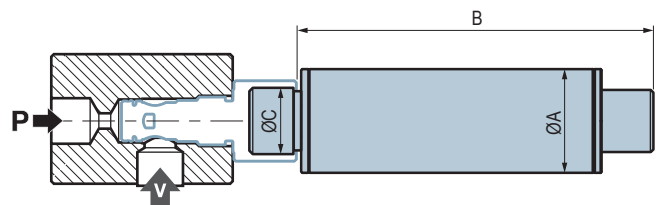

Controlled blow-off / multi-cartridge control valve

In addition to the CVP vacuum cartridges, COVAL has developed a CBP series pilot control valve used to provide equipment with a controlled blow-off function or to pneumatically control one or several CVP series vacuum cartridges.

→ See **CBP** Series, page 6/16.

CVPC

Controlled Vacuum Cartridges

General Information

The ultra-compact and light **CVPC** Series controlled vacuum cartridges are used to effortlessly install a vacuum generation system equipped with an electric control, as close to the corresponding application as possible. They perfectly meet the flexibility, customization and performance needs of machine manufacturers and integrators of robotic solutions, who want to easily design flexible, modular and efficient gripping tools.

CVPC Series controlled vacuum cartridges are suitable for a broad variety of applications and are available in different sizes and suction capacities:

- Size 1: nozzle dia. 1.2, 1.4 and 1.6 mm generating a suction flow rate ranging from 41 to 90 NI/min. Max. vacuum 85%.
- Size 2: nozzle dia. 2.2 and 2.7 mm generating a suction flow rate ranging from 160 to 215 NI/min. Max. vacuum 85%.

Advantages

- Ultra-light and compact cartridge design allows for great flexibility and easy integration.
- Integrated pilot control solenoid valve reduces response times.
- Vacuum technology: powerful single-stage Venturi that is dust resistant and maintenance-free.

Compact integration

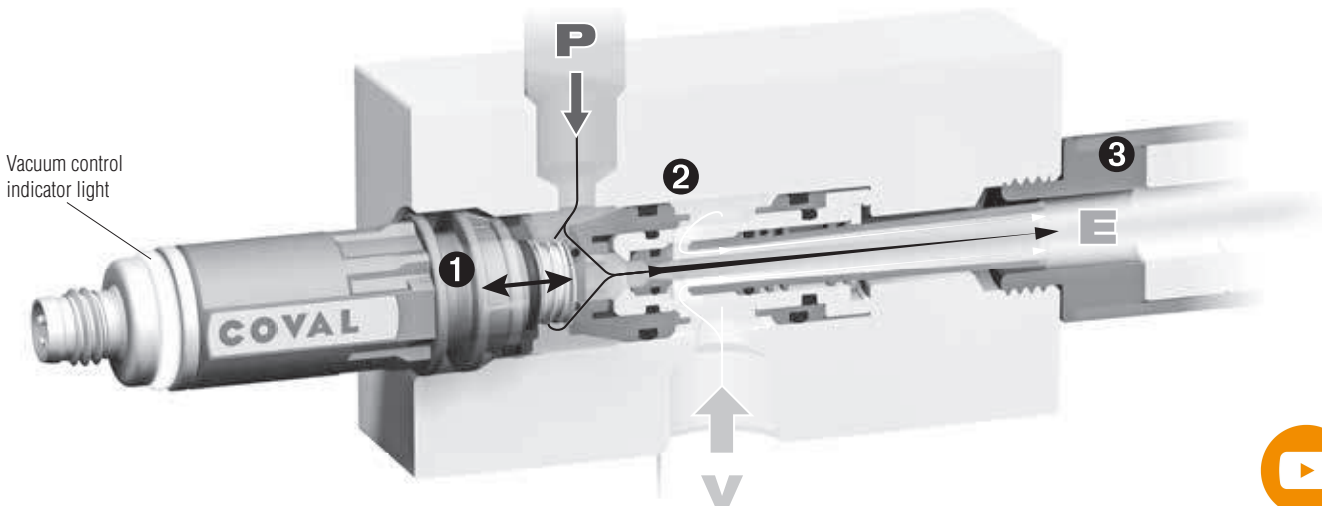

- ① Solenoid valve. ② Single-stage Venturi (nozzle + mixer system). ③ Option: non-clogging through-type silencer.

The innovative and patented design of the **CVPC** Series controlled vacuum cartridges combines two integrated functions:

- A single-stage Venturi that uses compressed air to generate a powerful vacuum, thus guaranteeing short evacuation times. The single-stage technology, consisting of a nozzle and a mixer, works without any moving parts, is dust resistant and maintenance-free.
- An electro-pneumatic valve that controls compressed air in order to regulate vacuum, ensuring high reactivity and thus a quick response time, meeting the requirements of ultra-fast pick & place applications.



Industry-specific applications

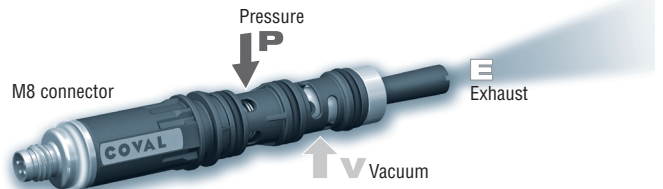
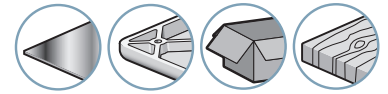

SIZE 1

Nozzle dia. 1.2, 1.4 or 1.6 mm



SIZE 2

Nozzle dia. 2.2 or 2.7 mm





CVPC

Controlled Vacuum Cartridges

Implementation, Applications

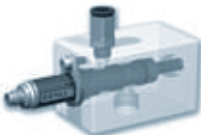
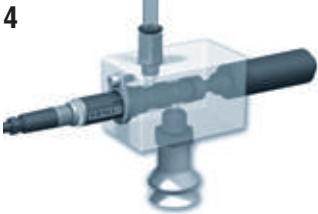

Implementation

- 1  1. Recess is machined to integrate the cartridge.
- 2  2. Vacuum cartridge is installed. Two mounting solutions are available: flange or threaded ring (see p. 6/15).
- 3  3. Peripheral equipment is assembled.
- 4  4. Pneumatic and electrical connections are established for use.



You will find the 3D files of the cartridges as well as the specifications of the machining operations to be carried out on our website www.coval.com

Application examples



- 1 CVPC series controlled vacuum cartridge
- 1 CBP series controlled blow-off cartridge
- 1 PSK series miniature electronic vacuum switch
- 1 FPC series FlowPack suction cup

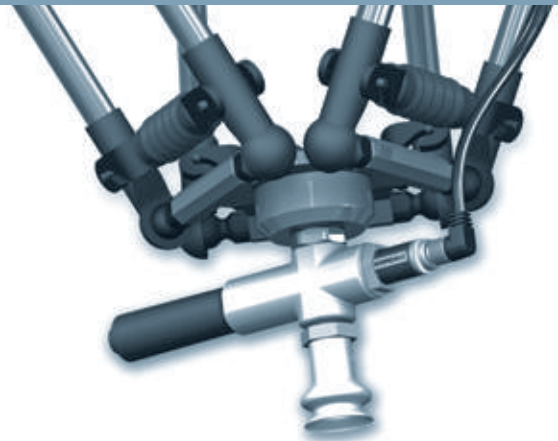

- 1 CVPC series controlled vacuum cartridge
- 1 MVS series soft and flexible suction cup



- 1 CVPC series controlled vacuum cartridge
- 6 VS series 2.5 bellows suction cups

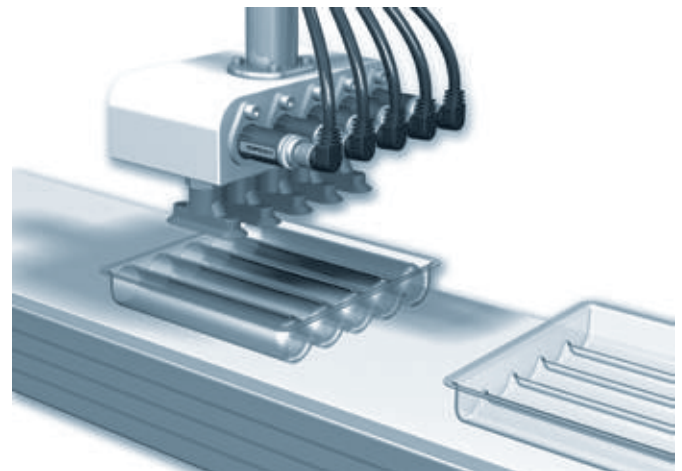

- 5 CVPC series controlled vacuum cartridges
- 5 VPO series oblong suction cups

CVPC

Controlled Vacuum Cartridges

Technical and Performance Data



Characteristics

Model	Ø nozzle (mm)	Air consumed (NI/min)	Maximum vacuum (%)	Air drawn in (NI/min)	At optimal air pressure (bar)
CVPC90x12	1.2	70	85	41	5 to 5.5
CVPC90x14	1.4	115	85	70	5 to 5.5
CVPC90x16	1.6	135	85	90	5 to 5.5
CVPC90x22	2.2	260	85	160	5 to 5.5
CVPC90x27	2.7	355	85	215	5 to 5.5

Evacuation time in seconds per liter

% vacuum	20	30	40	50	60	70	80
CVPC90x12	0.31	0.53	0.83	1.25	1.91	3.23	6.14
CVPC90x14	0.21	0.35	0.55	0.83	1.27	2.14	4.16
CVPC90x16	0.15	0.25	0.38	0.57	0.83	1.35	2.63
CVPC90x22	0.07	0.11	0.17	0.25	0.37	0.58	1.07
CVPC90x27	0.05	0.08	0.12	0.18	0.26	0.44	0.8

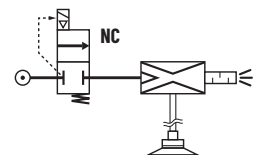
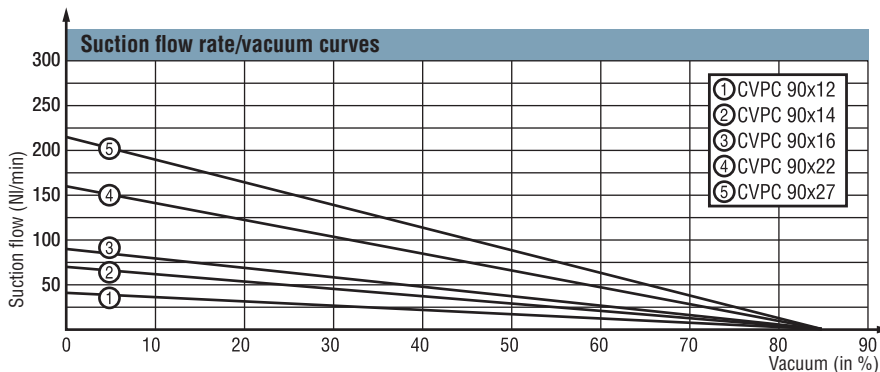
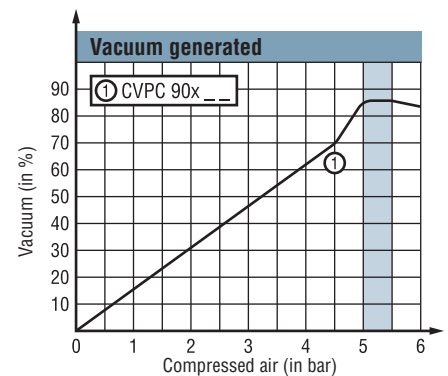
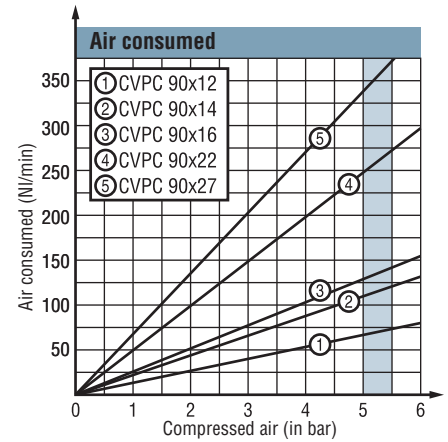

Dimensions and electrical connections

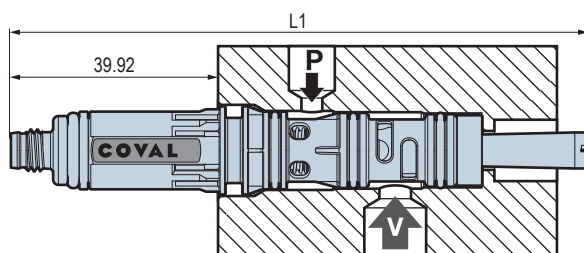

Model	L1	D1
CVPC90X12	98	16.9
CVPC90X14	105	16.9
CVPC90X16	110	16.9
CVPC90X22	134	16.9
CVPC90X27	147	16.9

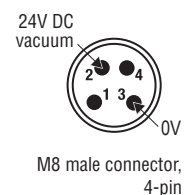

Note: All dimensions are in mm

Overall characteristics

- C.A. supply 5µ filtered, non-lubricated air relevant to standard ISO 8573-1:2010 [4:5:4].
- Operating pressure: 4.5 to 7 bar. (Optimal at 5 to 5.5 bar.)
- Max. vacuum: 85%.
- Suction flow rate: 41 to 215 NI/min depending on model.
- Air consumption: 70 to 355 NI/min depending on model.
- Electrical degree of protection: IP40.
- Control voltage: 24 V DC (regulated ±10%).
- Current drawn: 35 mA (0.84 W).

- Maximum operating frequency: 4 Hz.
- Endurance: 30 million cycles.
- Weight: 22 g.
- Operating temperature: from 0 to 50 °C.
- Materials: PA 6-6 15 % GF, brass, aluminum, NBR.
- Noise level with silencer (option K):
 - CVPC90X12K : 54 dBA
 - CVPC90X14K : 59 dBA
 - CVPC90X16K : 64 dBA
 - CVPC90X22K : 67 dBA
 - CVPC90X27K : 75 dBA

CVPC

Controlled Vacuum Cartridges

Ordering, Accessories



To place an order

	CVPC	90	X		12		K
	VACUUM LEVEL				NOZZLE DIAMETER		THROUGH-TYPE SILENCER
	85% max. vacuum	90			1.2 mm nozzle Ø	12	Without
					1.4 mm nozzle Ø	14	K With silencer
					1.6 mm nozzle Ø	16	
					2.2 mm nozzle Ø	22	
					2.7 mm nozzle Ø	27	

Mounting accessories

The CVPC controlled vacuum cartridges offer two mounting solutions:

Option CVPCFIX1

- Flange mounting

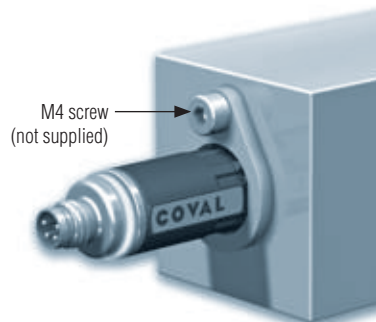
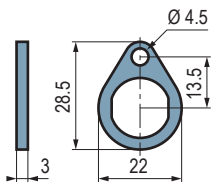

Option CVPCFIX2

- Mounting with G1/2"-M threaded ring

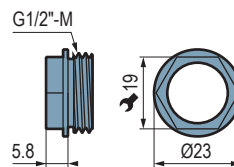

CVPC 6

Through-type silencers - option K

- Lateral noise absorption on sound-absorbing material.
- Unrestricted exhaust without pressure loss or clogging.
- Average sound attenuation of 20 dBA.

→ Silencer for **CVPC size 1**
(CVPC90X12K/CVPC90X14K/CVPC90X16K)

- **G1/4"-M** silencer
 - Materials: - aluminum thread
 - PA6 tube, 30% GF

→ Silencer for **CVPC size 2**
(CVPC90X22K/CVPC90X27K)

- **G1/2"-M** silencer
 - Material: - polycarbonate, 30% GF

Model	ØA	B	ØC	Weight (g)
Silencer for size 1	20	68	G1/4"-M	25
Silencer for size 2	30	121	G1/2"-M	92

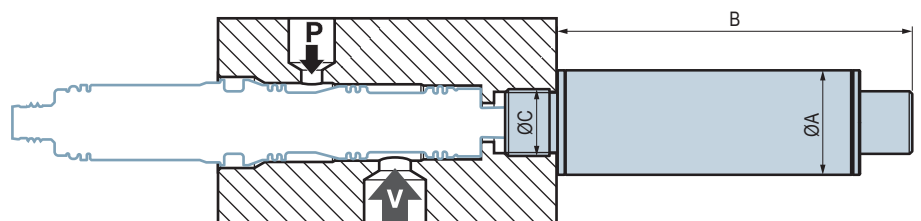

Blow-off valve

In some cases, a blow-off function must be added to the equipment to guarantee quick release and reduce cycle times. This is why COVAL developed an easy-to-integrate controlled blow-off cartridge.

→ See **CBP** Series, page 6/16.

CBP

Pilot Control Cartridge

General information



By means of a cylindrical cartridge design and an M8 connector, the **CBP** series pilot control cartridge easily fulfills the function of a compressed air control valve with an electric control installed as close as possible to where it is needed, and thus meeting the requirements of multiple applications.

The **CBP** Series pilot control cartridge is complementary to the CVPC Series controlled vacuum cartridges for its controlled blow-off function or, when combined with the CVP Series vacuum cartridges, for remote control and/or multi-cartridge control. It is easy to install and meets the needs of machine manufacturers and of integrators of robotic solutions in terms of flexibility and performance.

Industry-specific applications

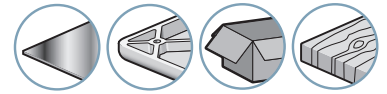

Advantages

- Ultra-light and compact cartridge design allows for great flexibility and easy integration.
- Pilot solenoid valve 2/2-way.
- Control indicator light.
- M8 connector.

Use cases

- Electro-pneumatic control valve 2/2-way.
- Blow-off control valve
- Single and multi-cartridge control valve.
- ...

Compact integration

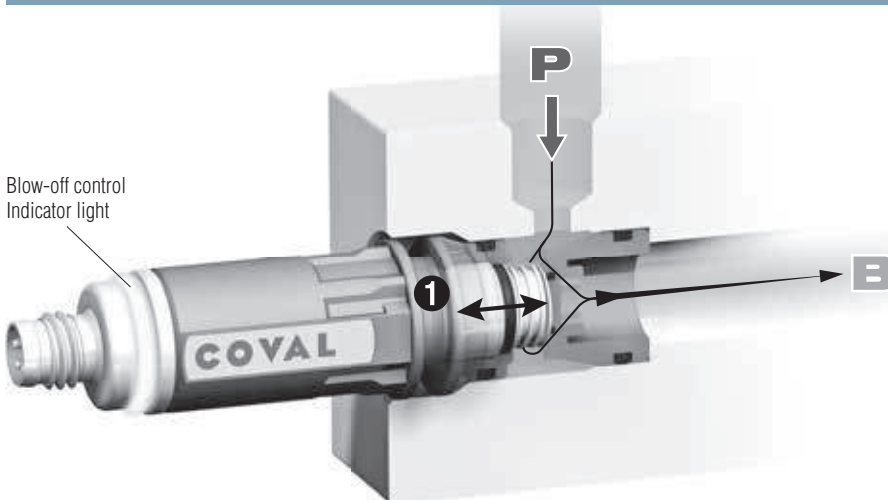

1 Solenoid valve.

The innovative and patented design of the **CBP** Series controlled blow-off / multi-cartridge control valve includes an electro-pneumatic valve that controls the compressed air, providing great reactivity and thus a very short response time.

Application examples

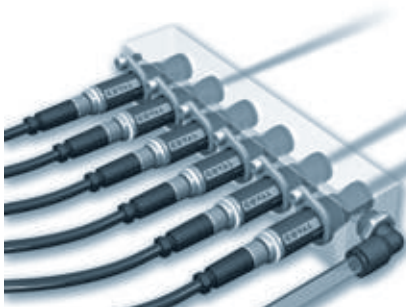

- 6 CBP series controlled blow-off cartridges

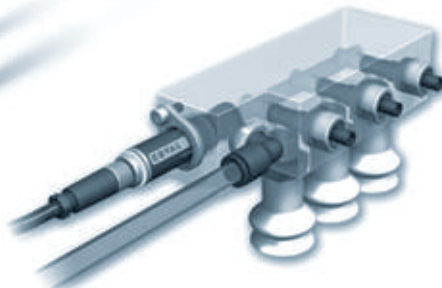





- 1 CBP series multi-cartridge control valve
- 3 CVP series vacuum cartridges
- 3 MVS series soft and flexible suction



- 1 CVPC series controlled vacuum cartridge
- 1 CBP series controlled blow-off cartridge
- 1 PSK series miniature electronic vacuum switch
- 1 FPC series FlowPack suction cup

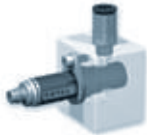

Implementation

1.  1. Recess is machined to integrate the cartridge.
2.  2. Cartridge is installed. Two mounting solutions are available: flange or threaded ring (see below).
3.  3. Peripheral equipment is assembled.
4.  4. Pneumatic and electrical connections are established for use.



You will find the 3D files of the cartridges as well as the specifications of the machining operations to be carried out on our website www.coval.com

Dimensions and electrical connections

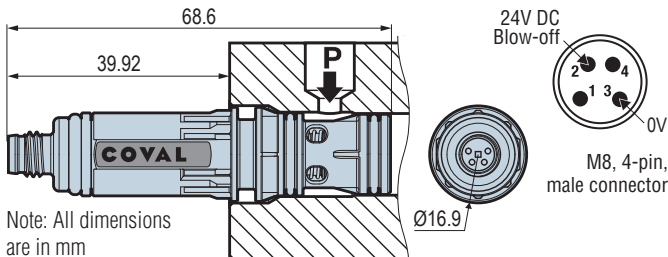

Characteristics

Model	Type	Nominal flow rate at 6 bar Δp_1 (NI/min)	Nominal diameter (mm)
CBP300	2/2	355	3

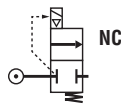

Overall characteristics

- C.A. supply 5 μ filtered, non-lubricated air relevant to standard ISO 8573-1:2010 [4:5:4].
- Operating pressure: 2.5 to 7 bar.
- Electrical degree of protection: IP40.
- Control voltage: 24 V DC (regulated $\pm 10\%$).
- Current drawn: 35 mA (0.84 W).
- Maximum operating frequency: 4 Hz.
- Endurance: 30 million cycles.
- Type of control mechanism: spring return leak valve controlled by an electromagnet.
- Response time for opening/closing: 20/30 ms.
- Weight: 18 g.
- Operating temperature: from 0 to 50 °C.
- Materials: PA 6-6 15 % GF, brass, aluminum, NBR.

To place an order

 **CBP 300**

FLOW RATE ↓

355 NI/min **300**

Capacity

- One CBP pilot control cartridge can be used to control several CVP vacuum cartridges:
- CVP90X12 > 5 cartridges
 - CVP90X14 > 3 cartridges
 - CVP90X16 > 2 cartridges
 - CVP90X22 > 1 cartridge
 - CVP90X27 > 1 cartridge

Mounting accessories

There are two mounting solutions for the CBP Pilot Control Cartridge:

Option CVPCFIX1

- Flange mounting.

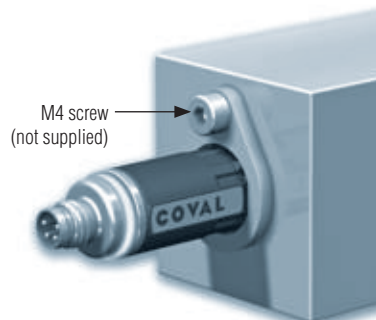
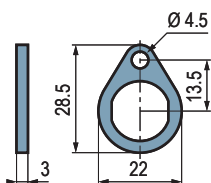

Option CVPCFIX2

- Mounting with G1/2"-M threaded ring.

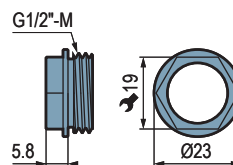

Vacuum Pumps without control

Chapter 7

GVP

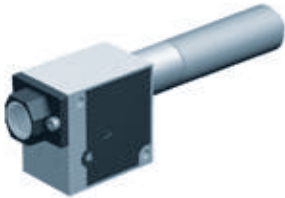

Vacuum Pumps

- Nozzle Ø: 1.2 ; 1.5 ; 2 ; 2.5 ; 3 mm
- Suction flow rate: 45 to 450 NI/min
- Optimum supply pressure: 4 bar
- Integrated silencer
- Modular design with interchangeable options
- Compact
- Optimized performance for handling all types of objects
- Silent operation
- No clogging
- Adaptable to all industries

P_{7/2}

GEMP

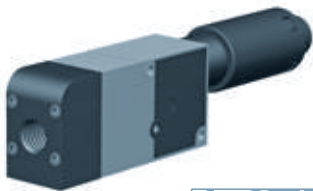

Simple Vacuum Pumps with ASR (Air Saving Regulator)

- Nozzle Ø: 1.2 ; 1.5 ; 2 ; 2.5 ; 3 mm
- 2 vacuum levels: 60% and 85%
- Suction flow rate: 72 to 385 NI/min
- Integrated supply pressure regulator (ASR)
- Integrated silencer
- Very compact and light-weight
- Exceptional energy savings thanks to automatic pressure regulation at 4 bar
- Optimized performance for handling all types of objects
- Silent operation
- No clogging

P_{7/8}

GVEC



“Easy Clean” Vacuum Pumps

- Nozzle Ø: 1.5 ; 2.5 ; 3 mm
- Suction flow rate: 95 to 330 NI/min
- Optimum supply pressure: 4 bar
- Materials resistant to corrosion and compatible with food-processing sector
- Very compact and light-weight
- Ideal for applications needing frequent cleaning
- Use in washing or splashing zones
- No clogging

P_{7/11}

LEMP



Mini Vacuum Pumps without control with ASR (Air Saving Regulator)

- Nozzle Ø: 1; 1.2; 1.4 mm
- 2 vacuum levels: 60% and 85%
- Suction flow rate up to 92 NI/min
- Integrated pressure regulator (ASR)
- With or without vacuum switch
- M8 connections
- Stand-alone or island module
- For airtight and porous objects
- Ultra compact and lightweight
- Control panel for monitoring and adjustment
- Energy savings in all networks > 4 bar
- Reduced wiring
- Reduced installation time
- Adaptable to all industries

P_{7/14}

GVP

Vacuum Pumps

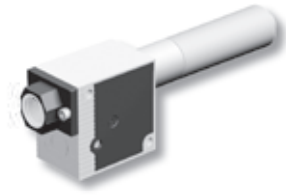

The GVP series vacuum pumps are the simplest in the range. They exist in 5 levels of power (suction rate) and 3 different levels of maximum vacuum:

- Version X (50% vacuum for very porous products).
- Version T (75% vacuum for porous products).
- Version N (85% vacuum for air-tight products).

For the same nozzle diameter, the suction flow rate increases proportionally to the decrease in the maximum vacuum level.

In addition to suction pads, they can also be used for dosing liquid, spraying and tank depressurization.

Industry-specific applications

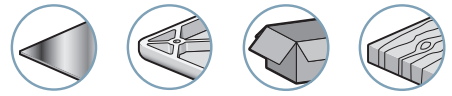

Characteristics

Model	Ø Nozzle (mm)	Air consumed (NI/min)	Max. vacuum (%)			Air drawn in (NI/min)			At air pressure (bar)
			X	T	N	X	T	N	
GVP 12	1.2	67	40	75	85	150	63	45	4
GVP 15	1.5	100	50	75	85	180	95	70	4
GVP 20	2	180	50	75	85	250	160	125	4
GVP 25	2.5	270	50	75	85	360	240	200	4
GVP 30	3	400	50	75	85	450	330	265	4

As standard, versions N and T are delivered with silencer S and version X with silencer K. Only exception, the GVP 30 is fitted with silencer K.

Advantages

- Adaptable to all industries
- Optimized performance for handling all types of objects
- Options
- Light and compact
- Silent operation
- No clogging thanks to the through type silencer

7
GVP

Evacuation Time in Seconds per Liter

% vacuum versions	10 %			20 %			30 %			40 %			50 %			60 %			70 %			80 %			85 %		
	X	T	N	X	T	N	X	T	N	X	T	N	X	T	N	X	T	N	X	T	N	X	T	N	X	T	N
GVP12	0.05	0.10	0.14	0.11	0.22	0.30	0.22	0.37	0.49	0.62	0.55	0.71	-	0.78	0.97	-	1.16	1.33	-	1.92	1.81	-	-	2.66	-	-	3.42
GVP15	0.04	0.07	0.09	0.09	0.15	0.20	0.15	0.24	0.32	0.27	0.36	0.46	-	0.52	0.63	-	0.77	0.85	-	1.27	1.16	-	-	1.71	-	-	2.20
GVP20	0.03	0.04	0.06	0.06	0.09	0.12	0.11	0.14	0.19	0.19	0.22	0.28	-	0.31	0.38	-	0.46	0.52	-	0.76	0.71	-	-	1.04	-	-	2.13
GVP25	0.02	0.03	0.03	0.04	0.06	0.07	0.08	0.10	0.11	0.14	0.14	0.16	-	0.21	0.22	-	0.30	0.30	-	0.50	0.41	-	-	0.60	-	-	0.77
GVP30	0.01	0.02	0.02	0.03	0.04	0.05	0.06	0.07	0.08	0.11	0.10	0.12	-	0.15	0.17	-	0.22	0.23	-	0.37	0.31	-	-	0.45	-	-	0.58

Specifications

Supply	Non-lubricated filtered air, pressure 2 to 6 bar
Optimum pressure	4 bar
Weight	100 to 265g
Material	POM - 2017A - Cu Zn
Temperature	0 to 80 °C

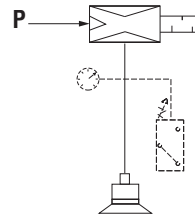

For all orders, please specify:
Model + Nozzle Ø + % vacuum + Silencer + C.A. fitting
 e.g.: GVP30NK14

1: Model	2: Nozzle diameter	3: % vacuum	4: Silencer	5: C.A. fitting		
GVP	12	1.2 mm	X	50 % vacuum	14	G1/4" Female
	15	1.5 mm	T	75 % vacuum		
	20	2 mm	N	85 % vacuum		
	25	2.5 mm				
	30	3 mm				

(1) no silencer for nozzle Ø 30.

GVP

Vacuum Pumps

Dimensions

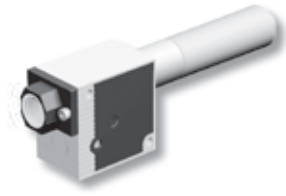

Dimensions

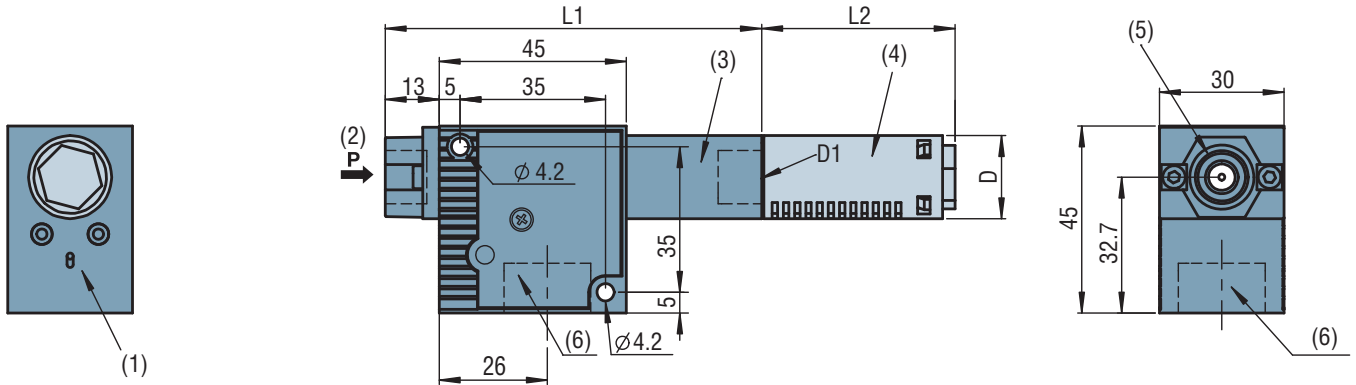

Models	L1		L2			D		D1	
	X	N/T	S(N/T)	K(N/T)	K(X)	X	N/T	X	N/T
GVP12	76	81	46	68	121	30	20	G1/2"-F	G1/4"-F
GVP15	76	91	46	68	121	30	20	G1/2"-F	G1/4"-F
GVP20	76	76	62	121	121	30	30	G1/2"-F	G1/2"-F
GVP25	76	76	62	121	121	30	30	G1/2"-F	G1/2"-F
GVP30	148	148	-	121	121	30	30	G 1/2"-F	G1/2"-F

- (1) Vacuum switch option mounting zone
- (2) 4 bar compressed air supply
- (3) Exhaust
- (4) Silencer model S or K
- (5) G1/4"-F
- (6) Vacuum G1/2"-F

Note: all dimensions are in mm

Options

- Vacuum switches see pages 7/5 and 7/6.
- Other options see pages 7/6 and 7/7.
- Silencer see page 11/11.

Curves

See page 7/4.

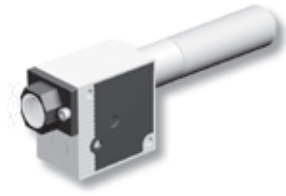

Vacuum Generated - Supply pressure 4 bar

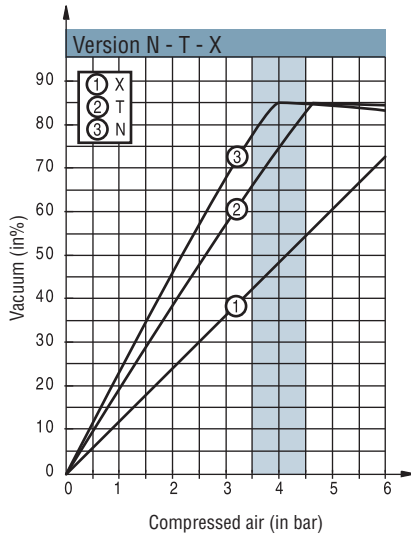

Air Consumed - Supply pressure 4 bar

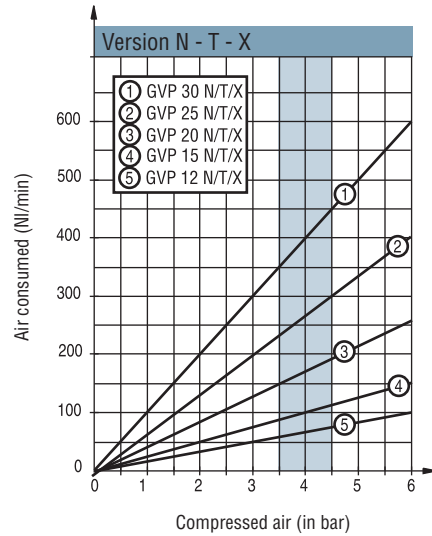

Suction Flow Rate/Vacuum Curves - Supply pressure 4 bar

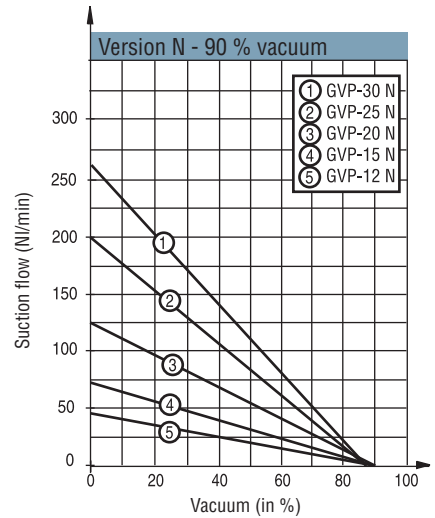
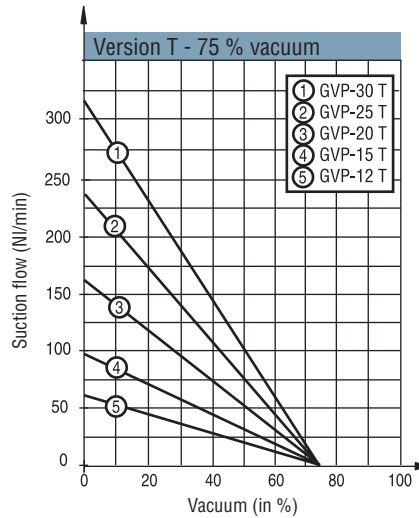
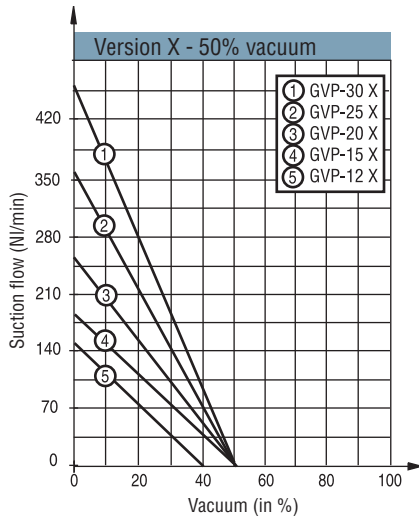

Suction Flow Rate Generated - Supply pressure 4 bar

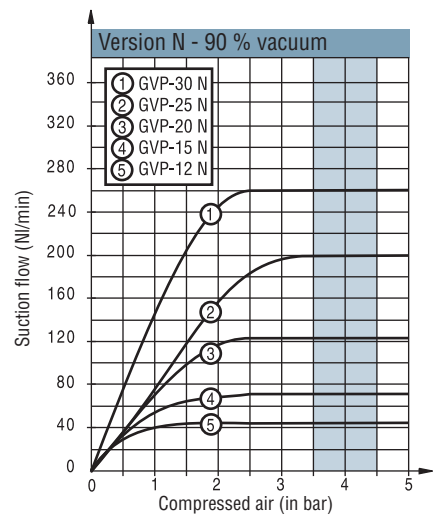
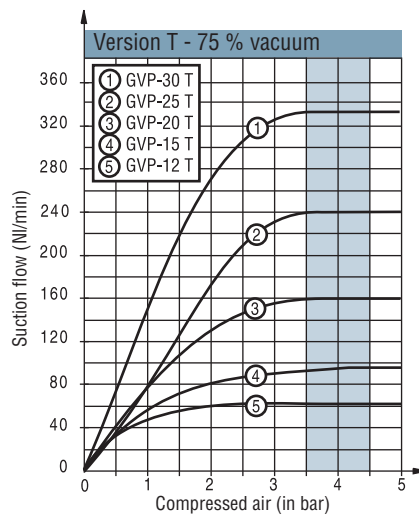
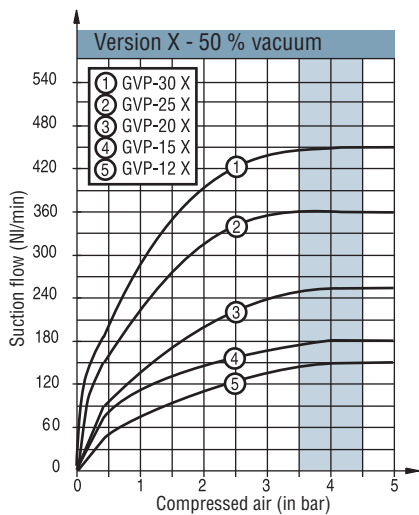

GVP 7

Customer-mounted Vacuum Pump Options

Electronic Vacuum Switch with Display

GVO PSA 100 C option

(See exact characteristics page 12/4)

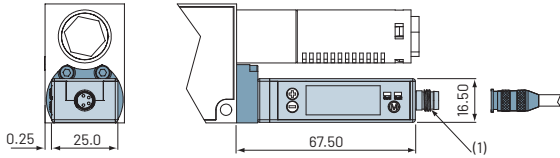

Delivered with M8 cable (2 meters)

(1) M8 connector

Our top-of-the-range electronic vacuum switch, the PSA 100C has an LED display showing the vacuum value in different units. It also has two separate outputs with independently regulated hysteresis, NO or NC

- PNP as standard
- M8 connector.
- Connection cable, see page 11/12.

Electronic Vacuum Switch

GVOPSP100CX option

(See characteristics page 12/7)

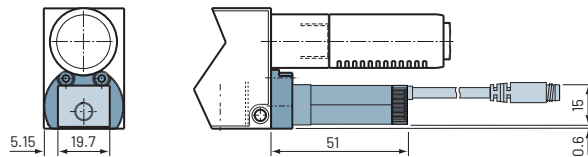

Delivered with M8 cable (2 meters)

(1) M8 4 pole connector

The vacuum data collected is always very reliable even with a large number of suction pads, thanks to the precision of the PSP100CX. It has one output with hysteresis adjustment.

- PNP as standard
- M8 connector.
- Connection cable, see page 11/12.

Vacuum Switch with Electrical Signal

GVO PSE 100 E or EC option

(See characteristics page 12/9)

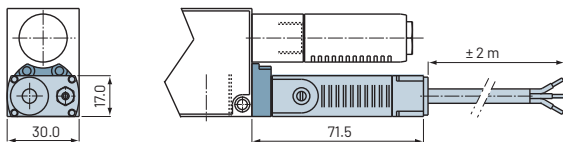

GVO PSE 100 E with cable (length 2 metres)

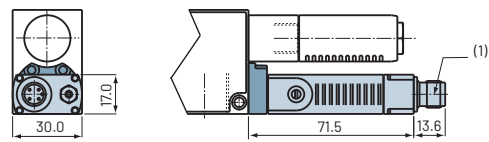

GVO PSE 100 EC with M12 connector (delivered without connection cable)

(1) M12 male connector

The PSE 100 E or EC vacuum switch indicates the level of vacuum in the suction pad circuit. For a small number of suction pads (5 to 10 maximum). This indication is enough to prove an object is gripped. Hysteresis (125mbar) must also be taken into account according to the use of the vacuum switch data.

Check that the vacuum pump supply pressure generates a level of pressure equal to the threshold setting.

For connection cable, see page 11/12.

Customer-mounted Vacuum Pump Options

Vacuum Switch with Pneumatic Signal

GVO PSE 100 P NO or NC option (see characteristics page 12/10)

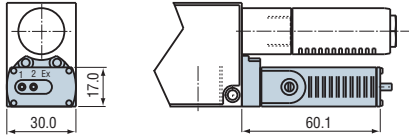

For use in fully pneumatic applications or explosive environments. The vacuum switch enables a pressure data message to be given when a vacuum threshold is reached.

Vacuum Gauge

GVO VAF 111 40 option (See characteristics page 12/12)

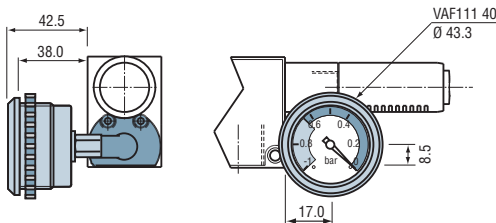

The vacuum gauge displays the level of vacuum in the suction pad circuit. This option makes it simple to keep the status of the vacuum circuit under constant surveillance.

7

Plug to Shut off Vacuum Data

GVOB Option

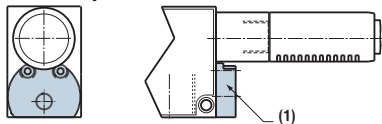

(1) Plug

This plug option makes it possible to shut off the vacuum signal to avoid affecting operation of the vacuum pump if a GVO option is removed.

Factory-mounted Vacuum Pump Options

GVO AL and GVO AL NPT option (for GVP vacuum pump)

Body and flange G1/4"-F Gas in aluminum (on request).

■ Note: It is no longer possible to mount vacuum gauge options.

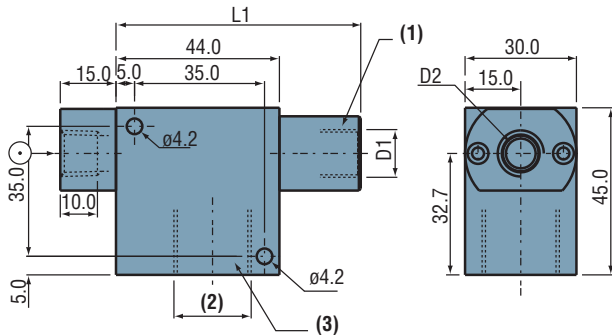

- | | | | |
|-------------|---------------------------------|------------|---------|
| L1 = | L1 GVP (plastic) - 1mm | (1) | Exhaust |
| D1 = | D1 (GVP N, T and X) | (2) | G1/2"-F |
| D2 = | G1/4"-F
1/4 NPT (on request) | (3) | Vacuum |

GVO P Option

With G1/2"-F protective extension.

The G1/2"-F extension is recommended for double valve models or with pneumatic vacuum switch to protect components during mounting or installation.

The extension is fitted with a 400 micron stainless steel filtration grid as standard.

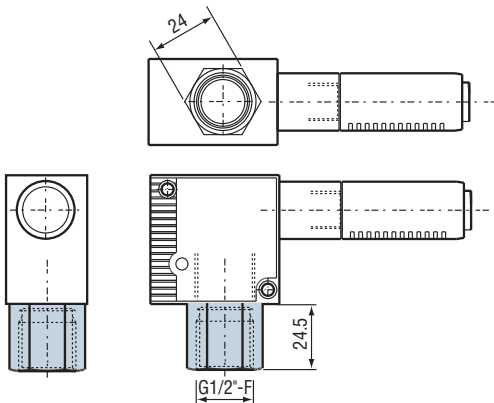

GEMP

Simple Vacuum Pump with ASR

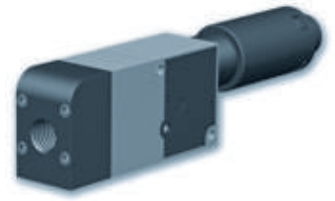

ASR Saving Regulator

The GEMP series vacuum pumps are the simplest in the energy-saving range. They automatically regulate the supply pressure to an optimal 4 bar thanks to an integrated pressure regulator (ASR). Energy savings are achieved regardless of the pressure in the compressed air network and without penalizing other applications which require more than 4 bar.

GEMP pumps therefore reduce both energy consumption and the noise level.

Industry-specific applications

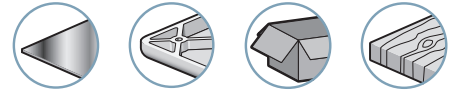

Characteristics

Models	Ø Nozzle (mm)	Air consumed (NI/min)	Maximum vacuum (%)	Air drawn in (NI/min)	At air pressure (bar)
GEMP60x12	1.2	65	60	72	4
GEMP60x15	1.5	97	60	110	4
GEMP60x20	2.0	179	60	189	4
GEMP60x25	2.5	260	60	275	4
GEMP60x30	3.0	385	60	385	4
GEMP90x12	1.2	65	85	50	4
GEMP90x15	1.5	97	85	75	4
GEMP90x20	2.0	179	85	125	4
GEMP90x25	2.5	260	85	200	4
GEMP90x30	3.0	385	85	245	4

Advantages

- Modular design with interchangeable options
- Compact and light
- Exceptional energy savings
- Optimized performance for all types of applications
- Silent operation
- No clogging

7
GEMP

Evacuation Time in Seconds per Liter

% vacuum	10	20	30	40	50	60	70	80	85
GEMP60x12	0.09	0.2	0.35	0.55	0.9	-	-	-	-
GEMP60x15	0.06	0.14	0.23	0.36	0.59	-	-	-	-
GEMP60x20	0.04	0.08	0.13	0.21	0.34	-	-	-	-
GEMP60x25	0.03	0.05	0.09	0.14	0.24	-	-	-	-
GEMP60x30	0.01	0.04	0.07	0.10	0.17	-	-	-	-
GEMP90x12	0.13	0.27	0.44	0.64	0.88	1.19	1.62	2.37	3.12
GEMP90x15	0.09	0.18	0.29	0.42	0.58	0.79	1.08	1.59	2.08
GEMP90x20	0.05	0.11	0.18	0.25	0.35	0.46	0.65	0.95	1.25
GEMP90x25	0.03	0.07	0.11	0.16	0.22	0.3	0.41	0.59	0.78
GEMP90x30	0.03	0.06	0.09	0.13	0.18	0.24	0.33	0.48	0.64

Specifications

Supply	Non-lubricated filtered air, 2 to 8 bar
Optimum pressure	4 bar
Weight	100 to 265g
Material	POM - 2017A – Cu Zn – PA6 15 % FV
Operating temperature	0 to 80 °C

Vacuum Switch Characteristics

See pages 7/9.



For all orders, please specify:
Model + % vacuum + X + Ø Nozzle + Vacuum switch.
 e.g.: GEMP90X12VA

1: Model	2: % vacuum	X	4: Nozzle diameter	5: Vacuum switch		
GEMP	60	X	12	1.2 mm	VA	electronic display
			15	1.5 mm	VB	electronic
	20		2 mm	VC	with electrical contact	
	25		2.5 mm	VO	without vacuum switch	
	30		3 mm			

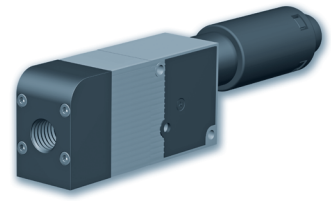

1 - Modules with Electronic Indexable Vacuum Switch GEMP-----VA or GEMP-----VB

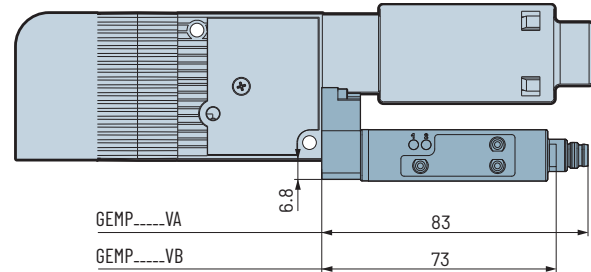
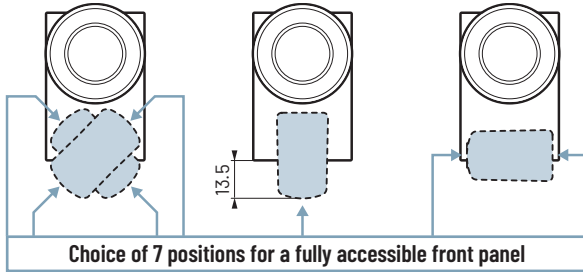

Vacuum switch with display, 2 outputs, GEMP-----VA

- compatible fluids: non-corrosive gas, dry, non-lubricated air.
- measuring range: -1 ... 0 bar
- hysteresis: configurable.
- maximum excess pressure: 3 bar.
- repetitivity: +/- 1% of the range.
- output thresholds: 2 x NO / NC.
- switching power: 125 mA transistor PNP
- threshold status display: 2 x LEDs.
- display unit: bar.
- Electrical connection: M8 (4 pins).
- supply voltage: 12 - 24 VDC ± 10%.
- current draw: < 60 mA.
- protection level: IP40.
- working temperature: 0 to 50 °C

Electronic vacuum switch, 1 output, GEMP-----VB

- compatible fluids: non-corrosive gas, dry, non-lubricated air.
- measuring range: -1 ... 0 bar
- hysteresis: configurable from 0 to 10%.
- maximum excess pressure: 3 bar.
- repetitivity: +/- 1% of the range.
- output thresholds: 1 x NO.
- switching power: 125 mA transistor PNP
- threshold status display: 1 x LED.
- electrical connection: M8 (4 poles).
- supply voltage: 18 - 30 VDC (regulated).
- current draw: < 20 mA.
- protection level: IP50.
- working temperature: 0 to 50 °C

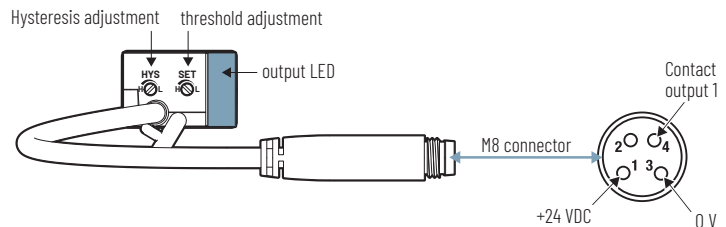
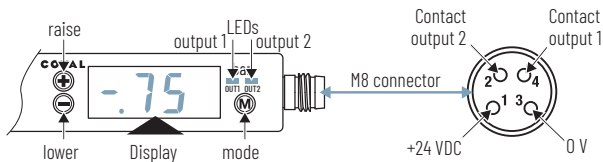

2 - Modules with Electrical Contact Vacuum Switch GEMP-----VC

Contact vacuum switch, GEMP-----VC

- compatible fluids: non-corrosive gas, dry, non-lubricated air.
- measuring range: -350 to -850 mb.
- hysteresis: 125 mb.
- maximum overpressure: 2 bar.
- repetitivity: 3% of the range.
- breaking capacity: 1 x NO, 1 x NC.
- switching power: 3 A (breaker)
- electrical connection: M12 (4 poles).
- supply voltage: up to 125 V.
- protection level: IP40.
- working temperature: -10 to 50 °C.
- number of operations: 5 million cycles.
- maximum throughput: 30 cycles per minute.

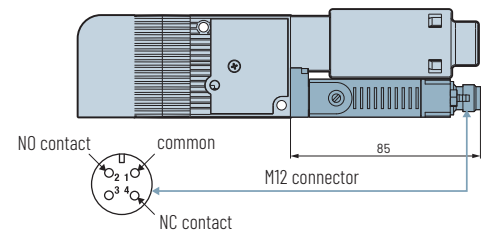

3 - Modules without Vacuum Switch GEMP-----V0

This model without vacuum switch must be accompanied by an independent vacuum switch on the vacuum circuit or a vacuum gauge for manually-controlled vacuum capacity.

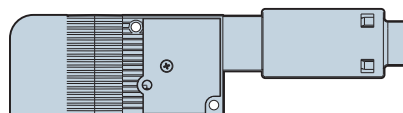

Note:

Screw-on electrical connectors, straight and angled M8 and M12 shown p. 11/12.

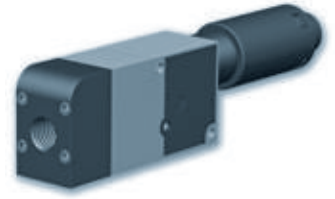

Dimensions

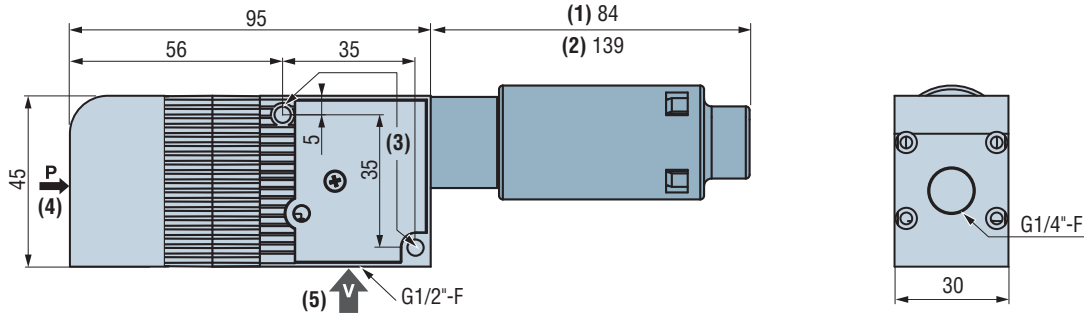

- (1) silencer for nozzles \varnothing 1.2 or 1.5 mm (GEMP--X12--, GEMP--X15--)
- (2) silencer for nozzles \varnothing 2 - 2.5 or 3 mm (GEMP--X20--, GEMP--X25--, GEMP--X30--)
- (3) fittings \varnothing 4.2 mm
- (4) G1/4"-F pressure fitting: pressure at 4 bar
- (5) G1/2"-F vacuum fitting

Performance Curves

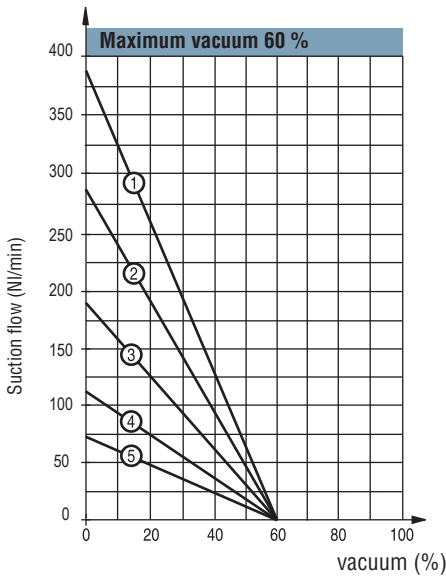

- 1 - GEMP60X30
- 2 - GEMP60X25
- 3 - GEMP60X20
- 4 - GEMP60X15
- 5 - GEMP60X12

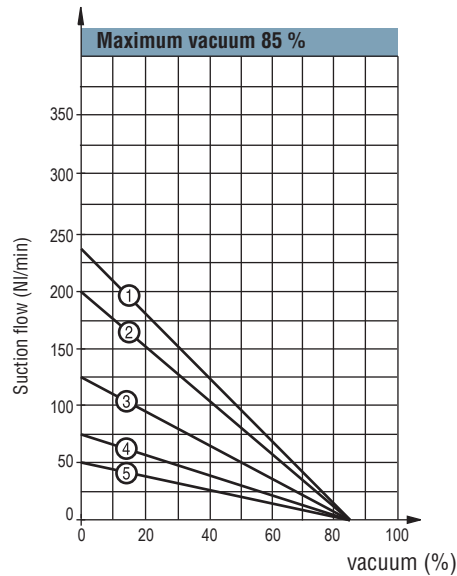

- 1 - GEMP90X30
- 2 - GEMP90X25
- 3 - GEMP90X20
- 4 - GEMP90X15
- 5 - GEMP90X12

Note: all dimensions are in mm



Industry-specific applications



The GVEC series “Easy Clean” vacuum pumps have been designed to meet the needs of vacuum handling applications in industries whose production requires frequent cleaning, particularly in the food-processing sector.

Characteristics

Model	Ø Nozzle (mm)	Air consumed (NI/min)	Max. vacuum (%)	Air drawn in (NI/min)	At air pressure (bar)
GVEC15T18	1.5	100	75	95	4
GVEC25T14	2.5	270	75	240	4
GVEC30T14	3	400	75	330	4

Advantages

- Plastic and stainless steel materials: meet the requirements of splash zones, are resistant to cleaning agents and corrosion.
- Compact and light design: installation as close as possible to suction cups to improve the evacuation times and production rate.
- Easy disassembly: quick and precise cleaning.

Evacuation Time in Seconds per Liter

% vacuum	10 %	20 %	30 %	40 %	50 %	60 %	70 %
GVEC15T18	0.07	0.15	0.24	0.36	0.52	0.77	1.27
GVEC25T14	0.03	0.06	0.10	0.14	0.21	0.30	0.50
GVEC30T14	0.02	0.04	0.07	0.10	0.15	0.22	0.37

Specifications

Supply	Non-lubricated filtered air, pressure 2 to 6 bar	
Optimum pressure	4 bar	
Weight	GVEC15T18	33 g
	GVEC25T14	139 g
	GVEC30T14	159 g
Material	Body and mixer	POM-C
	Nozzle	316L Stainless Steel
	Seal	EPDM
Operating temperature	From 0 to 50 °C	
Cleaning temperature	max. 100°C	

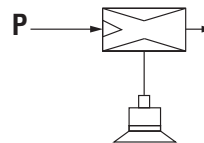

Specify the part number e.g.: GVEC25T14
Please refer to the characteristics table above



Dimensions

GVEC15T18

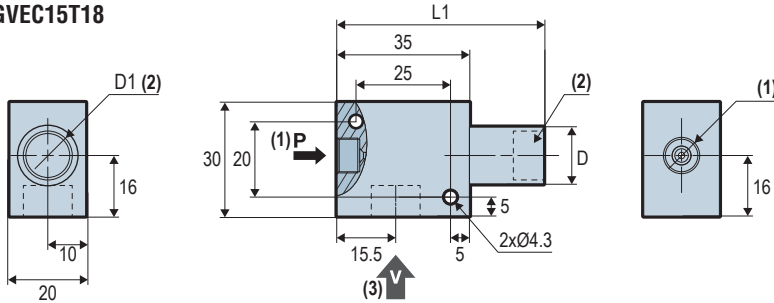

GVEC25T14 / GVEC 30T14

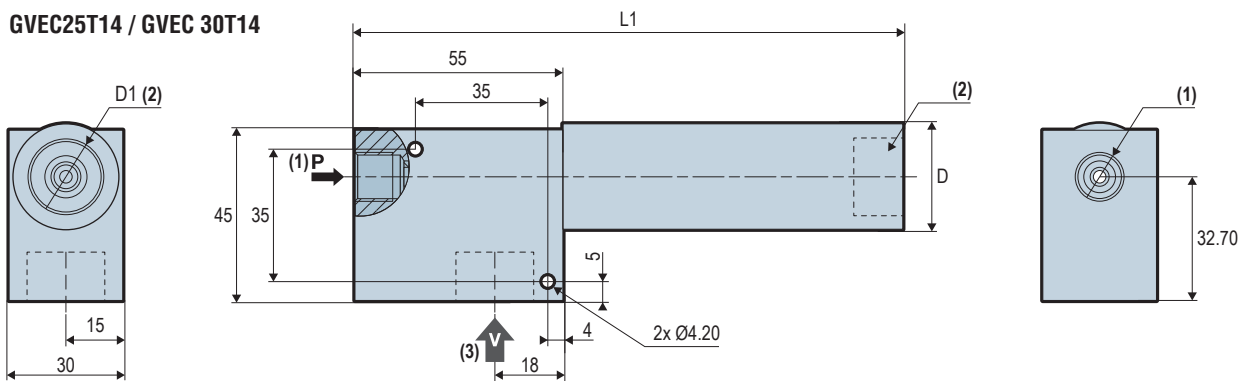

Models	L1	D	(1)	D1 (2)	(3)
GVEC15T18	54.6	16	G1/8"-F	G1/4"-F	G1/4"-F
GVEC25T14	120.9	28	G1/4"-F	G1/2"-F	G1/2"-F
GVEC30T14	144.9	28	G1/4"-F	G1/2"-F	G1/2"-F

- (1) Pressure fitting
- (2) Exhaust
- (3) Vacuum fitting

Note: all dimensions are in mm



Vacuum Generated - Supply pressure 4 bar

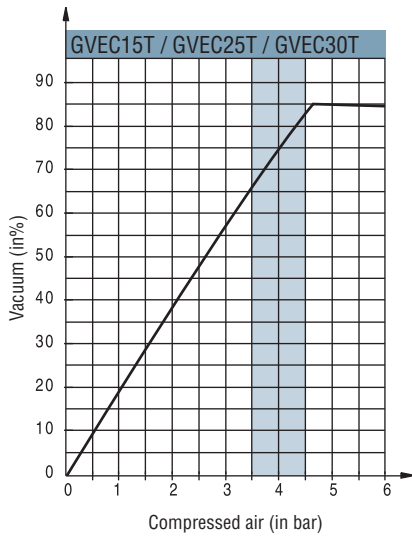

Air Consumed - Supply pressure 4 bar

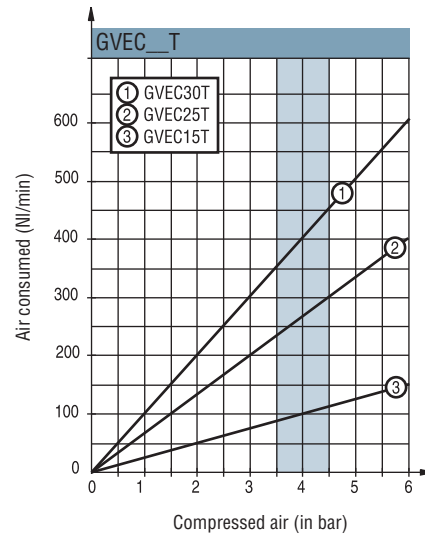

Suction Flow Rate/Vacuum Curves - Supply pressure 4 bar

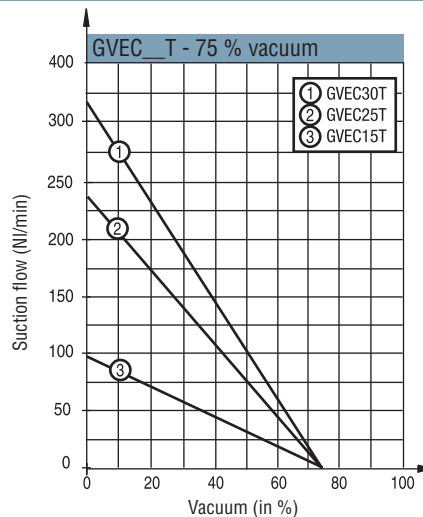

Suction Flow Rate Generated - Supply pressure 4 bar

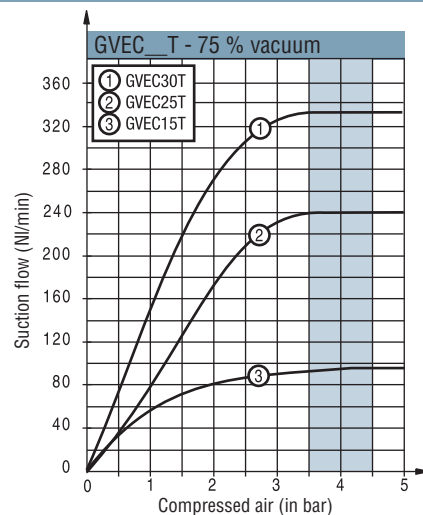

LEMP

Mini Vacuum Pumps without control with ASR (Air Saving Regulator)



AIRSaving
Regulator

Industry-specific applications

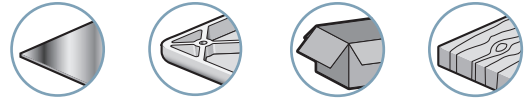

For all objects, porous or airtight

Advantages

- Simplified installation and use thanks to the Plug & Play system
- Unmatched compactness: Installation close to suction cups
→ short response times and energy savings.
- No clogging, thanks to the through-type silencer.
- A LEMP for every need: optional vacuum switch.
- Installation: standalone or island assembly.

Compact Integration

The illustrations below demonstrate the functions integrated in the mini-module, and their respective roles in operation. The result of this COVAL innovation is:

- **A mini module** (≈ 110 g) that is easy to install close to the suction cups, reducing the volume to be evacuated → increased speed and energy savings.
- **A complete module** (including integrated pressure regulator and clog-free silencer), therefore not requiring any additional function or connection.

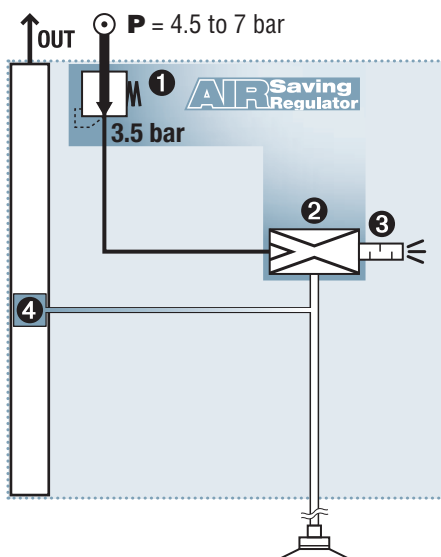

Integrated functions

- 1 3.5 bar Pressure regulator
- 2 3.5 bar optimized Venturi
- 3 Clog-free silencer
- 4 Electronic vacuum switch

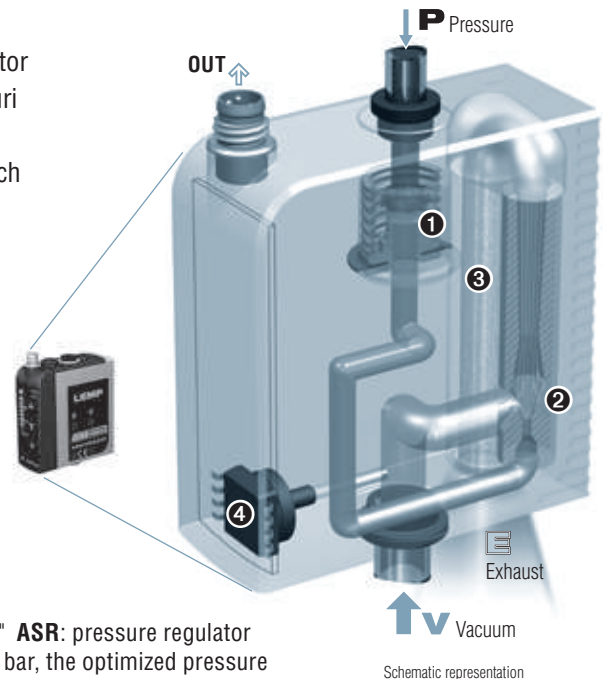

Combined "venturi regulator" **ASR**: pressure regulator **1** feeds venturi **2** with 3.5 bar, the optimized pressure for its operation.

→ **No more unnecessary consumption of compressed air.**

AIRSaving
Regulator

40% Energy savings

AIRSaving
Regulator **(ASR): Air Saving Regulator**

The LEMP vacuum pumps, which integrate an **ASR** "venturi regulator" combination, maintain ideals that COVAL values greatly: reducing both compressed air consumption and noise generation. Regardless of pressure supplied by the compressed air network, the integrated regulator feeds the venturi at **3.5 bar** pressure, optimal for its operation.

- No more unnecessary energy consumption.
- No external regulator required and thus the risk of inadvertent misadjustment is eliminated.

Compared to pressures found in most compressed air networks (5-7 bar), the graph opposite demonstrates an achieved economy of 40% on average.

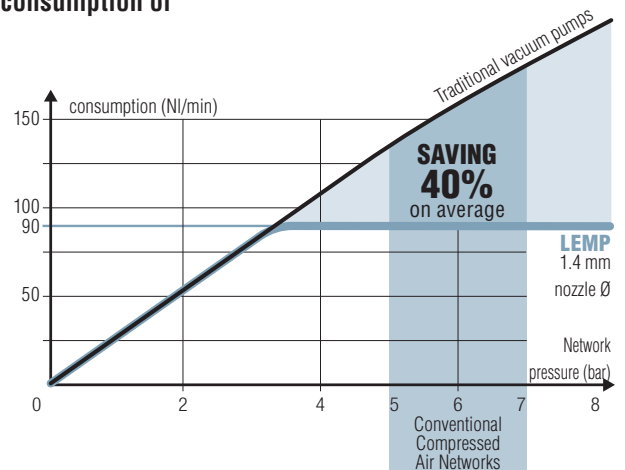



Version with Integrated Vacuum Switch

The front dialogue panel shown below displays the real-time vacuum level and lets the operator set the threshold level which triggers the "object gripped" signal allowing operations to continue. This communications panel is particularly visual and intuitive. It makes it easy to monitor production.

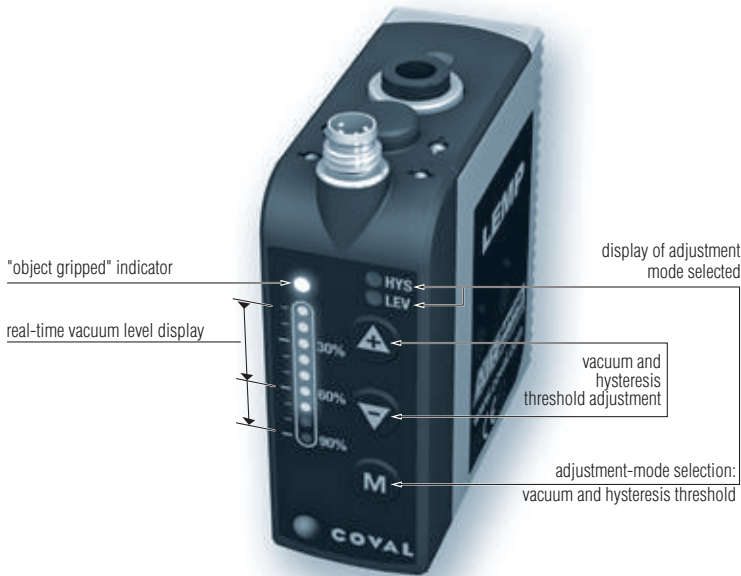

Stand-alone or Island Modules?

Stand-alone modules are suitable for the most common applications; one module controls one or more suction cups which all operate according to the same sequence.

When several suction cups are operating according to different sequences, multiple modules are required, which can be:

- several stand-alone modules,
- an island of these modules with an internal common pressure unit.

The diagrams below help in the selection:

- Stand-alone modules are complete, with the integrated pressure regulator
- in an island, the integrated regulator is absent: to maintain the advantage of economical and silent operation, it is recommended to reduce the pressure of the island's common pressure unit to 4 bar.

4.5 to 7 bar network pressure

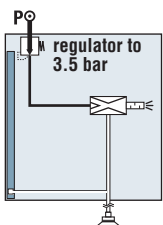

network pressure 4 bar

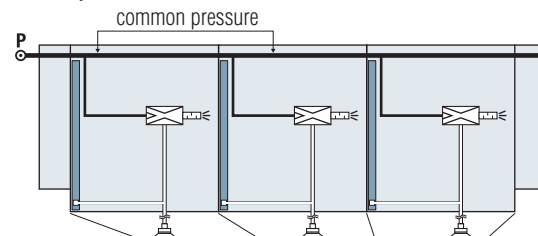

P optimal = 4 bar
(operation at 4-7 bar)



island of 3 modules
supplying suction cups



Select Vacuum Level and Nozzle Diameter

■ Airtight products handling: glass, plastic, coated wood, sheet metal...

Because vacuum leaks are limited, the vacuum level to be used may be high: between 50% to 80%, to be generated by a 85% max. vacuum level venturi.

Taking into account the volume to be emptied and the response time to do so, the chart below is a guide towards the most economical nozzle and gives the air suction flow.

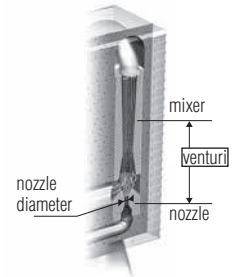

■ Porous products handling: cardboard, raw wood, pastries...

Significant porosity and/or surface vacuum leaks are to be expected. For handling, a vacuum level between 30% to 55% is the best compromise, to be generated by a 60% max. vacuum level venturi.

The chart below is a first indication towards the most economical nozzle ID, to be completed by a product leak flow measurement.

■ Porous materials:

cardboard, unfinished wood, pastries, etc.

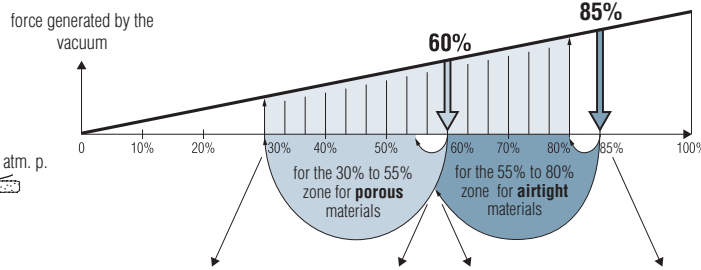
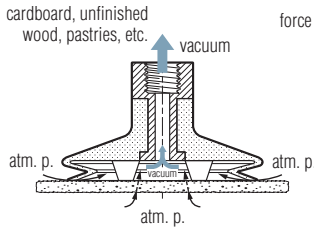

■ Airtight materials:

glass, plastic, sheet metal, finished wood

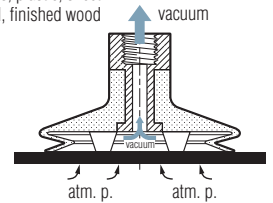

■ Porous Objects ▶ Maximum Vacuum Level: 60%

Time to create vacuum (seconds) for a volume of 1 liter

ø nozzle	vacuum achieved						Air consumed (NI/min)	Air drawn in (NI/min)
	30%	35%	40%	45%	50%	55%		
1.0 mm	0.66	0.83	1.04	1.31	1.70	2.35	44	38
1.2 mm	0.41	0.52	0.66	0.83	1.07	1.49	65	72
1.4 mm	0.27	0.34	0.43	0.54	0.70	0.97	90	92

■ Airtight Objects ▶ Maximum Vacuum Level: 85%

Time to create vacuum (seconds) for a volume of 1 liter

ø nozzle	vacuum achieved						Air consumed (NI/min)	Air drawn in (NI/min)
	55%	60%	65%	70%	75%	80%		
1.0 mm	1.76	2.04	2.38	2.80	3.33	4.09	44	29
1.2 mm	1.13	1.31	1.53	1.80	2.15	2.64	65	45
1.4 mm	0.73	0.85	0.99	1.16	1.38	1.70	90	70

Select with or without Vacuum Switch

For common applications, the vacuum switch is needed, with the dialogue face for digital display and adjustment.

However, some applications may just require a simple operation, without an "object gripped" return signal. The simplified version may then be chosen, with no vacuum switch, display, or adjustment.

Exhaust manifold: option E

The LEMP mini vacuum pumps can be equipped with the "exhaust manifold" option, which provides a G1/8"-F connection to the exhaust in order to add a silencer, transfer the exhaust outside the work area or to avoid air discharge near the workpiece (LEMP__E version).

This option must be specified at time of ordering as it cannot be added later.

Note: The design of the exhaust manifold and vacuum pumps do not guarantee the complete sealing of the exhaust and therefore cannot be used in a "clean room" environment.

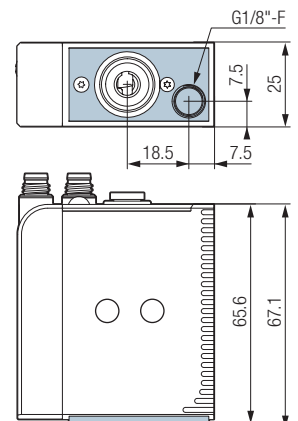









Part numbers for an island assembly or components in an island

Part numbers for stand-alone units

 **LEMP 60 X 12 VA - B3**

VACUUM LEVEL		VACUUM SWITCH		ISLAND ASSEMBLIES	
60% max. vacuum → porous objects	60	VA	<ul style="list-style-type: none"> Electronic vacuum switch with digital display and adjustment 	B2	 <p>LEMP_X...B2 island assembly with 2 identical modules.</p>
85% max. vacuum → airtight objects	90	VO	<ul style="list-style-type: none"> No vacuum switch and no adjustment 	B3	 <p>LEMP_X...B3 island assembly with 3 identical modules.</p>
				B4	...
NOZZLE DIAMETER		EXHAUST			
Ø 1 mm nozzle	10	Open (integrated silencer)		-	
Ø 1.2 mm nozzle	12	Exhaust manifold (G1/8"-F)		E	
Ø 1.4 mm nozzle	14				

If the planned island contains different module types, it must be ordered as separate components in order to then be assembled on site according to the arrangement suitable to the application.

COMPONENTS FOR THE ISLAND TO BE ASSEMBLED	
B	 <p>LEMP_X...B Module that can be grouped (complete with integrated grouping screw).</p>
	<p>Set of ends for a complete group, with grouping screw and common pressure unit plug.</p> <p>PART NO.: LEMSETA</p>

Accessory

Protection for standalone mini vacuum pumps LEMP_VA (with one M8 connector), Part No.: **80004409**

The COVER is made of silicone and serves as a protective sleeve for vacuum pumps, protecting them against splashing water, in particular during cleaning cycles.

- High level of protection against splashing water.
- Easy to mount and clean.



EXAMPLE COMPOSITE PART NUMBER FOR AN ISLAND ASSEMBLY:

■ LEMP60X14VAB3

LEMP island assembly, containing 3 x 60% max. vacuum modules, Ø1.4 mm nozzle and vacuum switch.

ORDER EXAMPLE FOR AN ISLAND TO BE ASSEMBLED:

■ LEMP60X10VAB

■ LEMP90X12VAB

■ LEMP60X14VAB

■ LEMSETA

3 LEMP modules for a group, of different types.

Set of ends for island.

REFERENCE EXAMPLE COMPOSED OF A STAND-ALONE MODULE:

■ LEMP60X12VA

Stand-alone LEMP Module, 60% max. vacuum, Ø1.2 mm nozzle and vacuum switch.



Stand-alone Modules



Side mounting

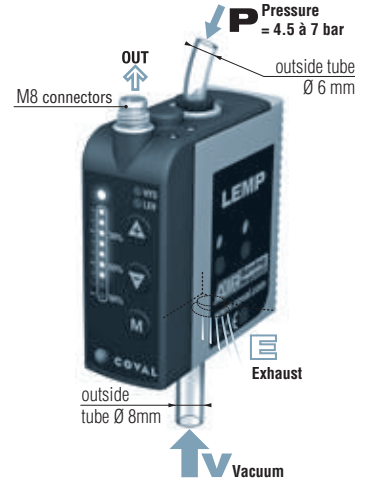
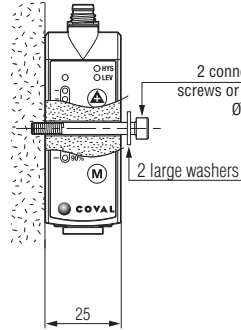
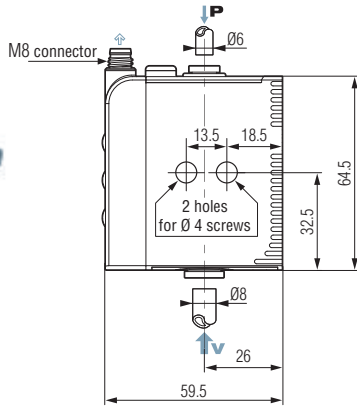

Front mounting

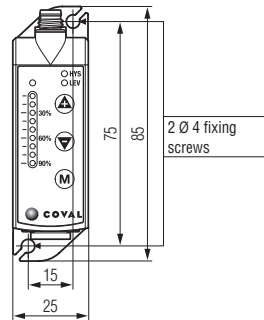
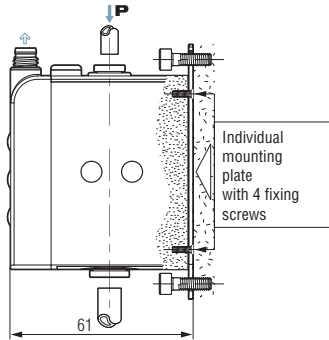

For front mounting, order the necessary kit, in addition to the module:

Front mounting kit:
1 plate + 4 screws

Part No.: LEMFIXA



Mounting on DIN rail

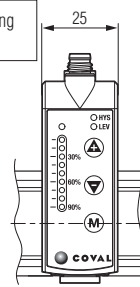
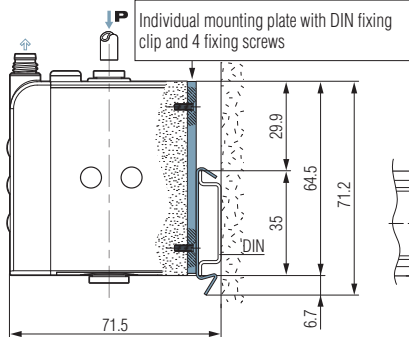

A module can be clipped onto a DIN rail. For this purpose, the module must first be equipped with an individual DIN installation plate, ordered separately:

DIN rail mounting kit:
1 plate/clip + 4 screws

Part No.: LEMFIXB

Islands

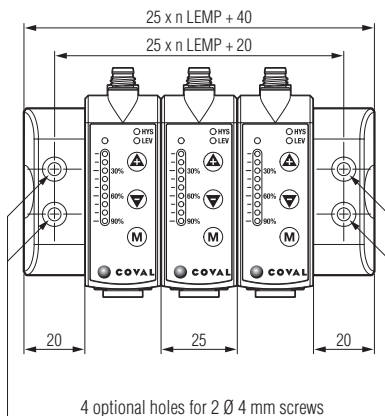

Front mounting

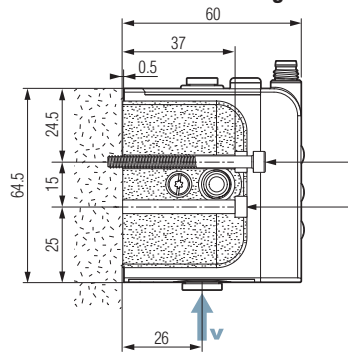

2 optional holes for 1 Ø 4 mm connecting screw, at each end of the island

Mounting on DIN rail

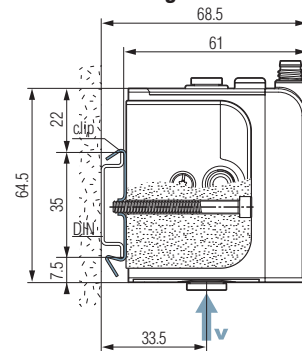

DIN rail mounting kit:
2 clips + 2 screws

Part No.: LEMFIXC



Overall Characteristics

- Supply: non-lubricated air filtered to 5 microns according to standard ISO 8573-1:2010 [4:5:4].
- Operating pressure: 4.5 to 7 bar.
- Mini dynamic pressure:
 - stand-alone module: P = 4.5 bar.
 - island modules: P = 4 bar.
- Maximum vacuum: 60% or 85% depending on model.
- Suction rate: 29 to 92 NI/min depending on model.
- Air consumption: 44 to 90 NI/min depending on model.
- Electrical protection level: IP 65.
- Weight: 90 to 110 g, depending on model.
- Operating temperature: 0 to 50 °C.
- Materials: PA 6-6 15 %FV, brass, aluminum, NBR.

Integrated Vacuum Switch Characteristics

- Measuring range: -1 to 0 bar.
- Precision: $\pm 1.5\%$ of the range.
- Hysteresis: adjustable from 0% to 100%.
- Output threshold: 1 x T.O.R. in NO.
- Analog output: 1 V DC to 5 V DC on the measuring range.
- Switching power: 125 mA, PNP.
- Threshold status display: 1 green LED.
- Supply voltage 24V DC (regulated $\pm 10\%$).
- Current draw: < 20 mA.
- Protection: against polarity inversions.

Integrated Silencer Characteristics

- Noise level: approximately 68 dBA.
- Clog-free silencer.

Electrical Connections

MODULES WITH VACUUM SWITCH FUNCTION

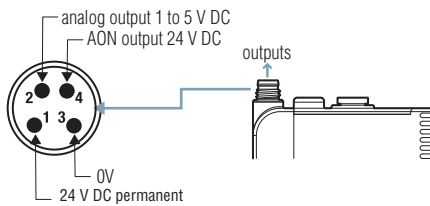

Accessories



Power supply cable M8, straight, female, 4-pin – open end:

- **CDM8**: length. 2 m.
- **CDM8N**: length. 0.5 m.

Power supply cable M8, elbow, female, 4-pin – open end:

- **CCM8**: length. 2 m.

Characteristics and Connecting an Island

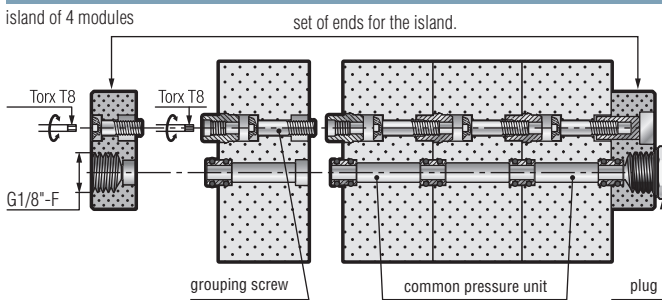

island of 3 modules



Maximum number of modules in an island:

- \varnothing 1.4 mm nozzle \rightarrow 5 modules
- \varnothing 1.2 mm nozzle \rightarrow 7 modules
- \varnothing 1 mm nozzle \rightarrow 9 modules

Suction Flow Rate / Vacuum Curves

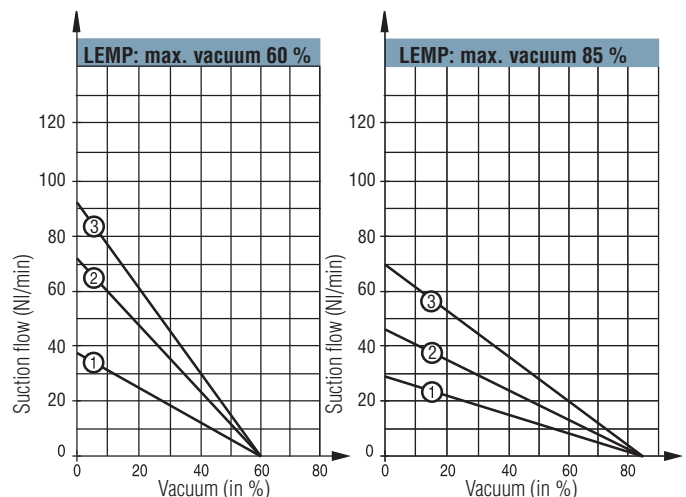

- 1 - LEMP60X10
- 2 - LEMP60X12
- 3 - LEMP60X14

- 1 - LEMP90X10
- 2 - LEMP90X12
- 3 - LEMP90X14

Intelligent Vacuum Pumps

Chapter 8

LEM



ASR Saving Regulator

Integrated Mini Vacuum Pumps with ASR (Air Saving regulator)

- Nozzle Ø: 1; 1.2; 1.4 mm
- 2 vacuum levels: 60% and 85%
- Suction flow rate up to 92 NI/min
- Integrated pressure regulator (ASR)
- All required functions integrated internally
- M8 connections
- Stand-alone or island module
- For airtight and porous objects
- Ultra compact and lightweight
- Control panel for monitoring and adjustment
- Energy savings in all networks > 4 bar
- Reduced wiring
- Reduced installation time
- Adaptable to all industries

P 8/3

LEMAX



ASR Saving Control

Integrated Mini Vacuum Pumps with ASC (Air Saving Control)

- Nozzle Ø: 1; 1.2; 1.4 mm
- Vacuum level: 85%
- Suction flow rate up to 70 NI/min
- Integrated pressure regulator (ASR)
- Integrated vacuum regulation (ASC)
- All required functions integrated internally
- M8 connections
- Stand-alone or island module
- For sealed or slightly porous parts
- Ultra compact and lightweight
- Control panel for monitoring and adjustment
- ASC = 75% to 90% energy savings
- Reduced wiring
- Reduced installation time
- Adaptable to all industries

P 8/11

LEMAX IO



IO-Link **ASR** Saving Control

Mini Vacuum Pumps with Communication IO-Link

- Nozzle Ø: 1; 1.2; 1.4 mm
- Vacuum level: 85%
- Suction flow rate up to 70 NI/min
- Integrated pressure regulator (ASR)
- Integrated vacuum regulation (ASC)
- IO-Link
- M8 connections
- Stand-alone or island module
- For sealed or slightly porous parts
- Ultra compact and lightweight
- Settings and diagnosis by remote monitoring.
- ASC = 75% to 90% energy savings
- Easy installation and operation thanks to the IO-Link communication interface
- Adaptable to all industries

P 8/19

LEMCOM



PROFINET **ASR** Saving Control
EtherNet/IP

Mini Vacuum Pumps Communicating via Industrial Field Bus

- Nozzle Ø: 1; 1.2; 1.4 mm
- 2 vacuum levels: 60% and 85%
- Suction flow rate up to 92 NI/min
- Integrated pressure regulator (ASR)
- Integrated vacuum regulation (ASC)
- Field bus: PROFINET, EtherNet/IP™
- M8 connections
- Stand-alone or island module
- For sealed or slightly porous parts
- Ultra compact and lightweight
- Settings and diagnosis by remote monitoring.
- ASC = 75% to 90% energy savings
- Reduced wiring
- Reduced installation time
- Adaptable to all industries

P 8/27

LEM+



ASR Saving Regulator

Compact High Flow Vacuum Pumps with ASR (Air Saving Regulator)

- Nozzle Ø: 2; 2.5 mm
- 2 vacuum levels: 60% and 85%
- Suction flow rate up to 275 NI/min
- Integrated pressure regulator (ASR)
- All required functions integrated internally
- M12 connections
- For airtight and porous objects
- Compact and lightweight
- Control panel for monitoring and adjustment
- Energy savings in all networks > 4 bars
- Reduced wiring
- Reduced installation time
- Adaptable to all industries

P 8/39

Intelligent Vacuum Pumps

Chapter 8

LEMAX+



Compact High Flow Vacuum Pumps with ASC (Air Saving Control)

- Nozzle Ø: 2 ; 2.5 mm
- Vacuum level: 85%
- Suction flow rate up to 200 NI/min
- Integrated pressure regulator (ASR)
- Integrated vacuum regulation (ASC)
- All required functions integrated internally
- M12 connections
- For sealed or slightly porous parts
- Compact and lightweight
- Control panel for monitoring and adjustment
- ASC = 75% to 90% energy savings
- Reduced wiring
- Reduced installation time
- Adaptable to all industries

P 8/45

GVMAX HD



Heavy Duty Communicating Vacuum Pumps

NFC))) IO-Link AIR Saving Control

- Nozzle Ø: 2.5 ; 3 mm
- Vacuum level: 85%
- Suction flow rate up to 230 NI/min
- Integrated vacuum regulation (ASC)
- Standard In/Out (SIO) and IO-Link
- NFC
- M12 connections
- Standalone vacuum pumps or in island assemblies
- For sealed or slightly porous parts
- High visibility color display with clear multi-lingual messages and straightforward settings menu
- ASC = 75% to 90% energy savings
- Easy installation and operation thanks to the IO-Link communication interface
- Easy set up made possible by NFC technology and COVAL Vacuum Manager mobile application
- Adaptable to all industries

P 8/51

CMS HD



Heavy Duty Multi-stage Vacuum Pumps

NFC))) IO-Link

- 3 powerful suction flow rates from 700 NI/min to 1600 NI/min
- Vacuum level: 80%
- With or without vacuum and blow-off control
- M12 connections
- Digital inputs/outputs mode (SIO) / IO-Link
- NFC
- 3 exhaust configurations
- For airtight and porous objects
- High visibility color display with clear multi-lingual messages and straightforward settings menu
- Easy installation and operation thanks to the IO-Link communication interface
- Easy set up made possible by NFC technology and COVAL Vacuum Manager mobile application
- Adaptable to all industries

P 8/65

Integrated Mini Vacuum Pumps with ASR (Air Saving Regulator)



ASR Saving Regulator

Industry-specific applications

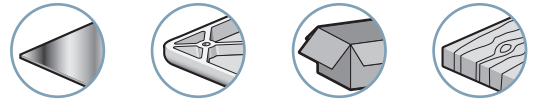

For all objects, porous or airtight

Advantages

- "All-in-one" solution, no more peripherals to be added.
- Simplified installation and use thanks to the Plug & Play system
- Unmatched compactness: Installation close to suction cups → short response times and energy savings.
- No clogging, thanks to the through-type silencer.
- A LEM for every need: a wide range, with many options.
- Smart dialogue → user friendly at all stages: initial settings, operation, maintenance.

Compact Integration

The illustrations below demonstrate the 8 functions integrated in the mini-module, and their respective roles in operation. The result of this COVAL innovation is:

- **A mini module** (≈ 120 g) that is easy to install close to the suction cups, reducing the volume to be evacuated → increased speed and energy savings.
- **A complete module** (including integrated pressure regulator and clog-free silencer), therefore not requiring any additional function or connection.

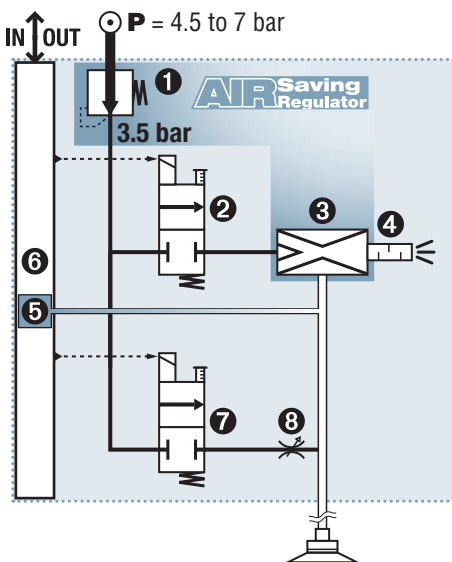

Integrated functions

- 1 3.5 bar pressure regulator
- 2 Solenoid valve "vacuum"
- 3 3.5 bar optimized Venturi
- 4 Clog-free silencer
- 5 Electronic vacuum switch
- 6 Integrated electronics
- 7 Solenoid valve "blow-off"
- 8 Blow-off flow adjustment

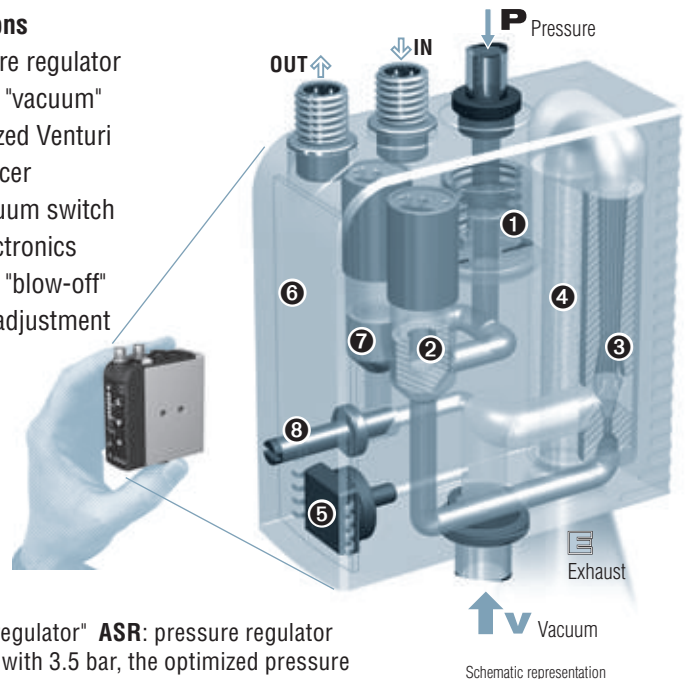

Combined "venturi regulator" **ASR**: pressure regulator 1 feeds venturi 3 with 3.5 bar, the optimized pressure for its operation.

→ **No more unnecessary consumption of compressed air.**

ASR Saving Regulator

40% Energy savings

ASR (ASR): Air Saving Regulator

The LEM vacuum pumps, which integrate an **ASR** "venturi regulator" combination, maintain ideals that COVAL values greatly: reducing both compressed air consumption and noise generation.

Regardless of pressure supplied by the compressed air network, the integrated regulator feeds the venturi at **3.5 bar** pressure, optimal for its operation.

- No more unnecessary energy consumption.
- No external regulator required and thus the risk of inadvertent misadjustment is eliminated.

Compared to pressures found in most compressed air networks (5-7 bar), the graph opposite demonstrates an achieved economy of 40% on average.

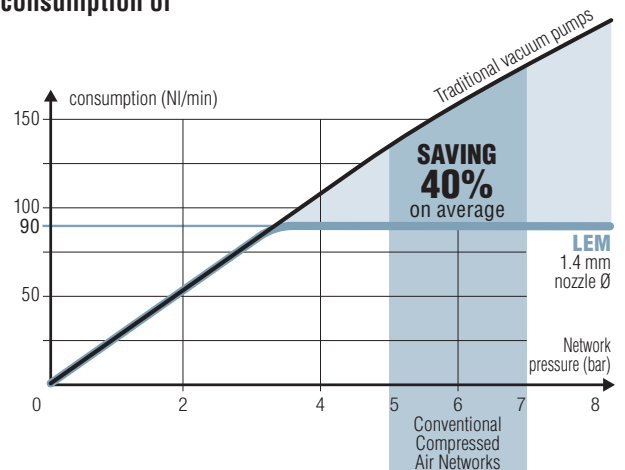

Integrated Mini Vacuum Pumps with ASR Smart Dialogue / Stand-alone and Island Modules



ASR Saving Regulator

A Complete Line

- 4 basic configurations, see adjacent illustrations →
- 2 levels : 60% and 85% vacuum.
- 3 standard nozzle diameters: 1, 1.2 and 1.4 mm.
- Air suction flow : up to 92 NI/min.
- Other options on request.

with vacuum switch, display and setting



with blow-off
(LEM_X_SVA)



without blow-off
(LEM_X_RVA)

without vacuum switch



with blow-off
(LEM_X_SVO)



without blow-off
(LEM_X_RVO)

Smart Dialogue

The front dialogue panel shown here displays the real-time vacuum level and lets the operator set the threshold level which triggers the "object gripped" signal allowing operations to continue. This communications panel is particularly visual and intuitive. It makes it easy to monitor production by viewing each of the phases of the cycle: vacuum, blow-off, and rest.

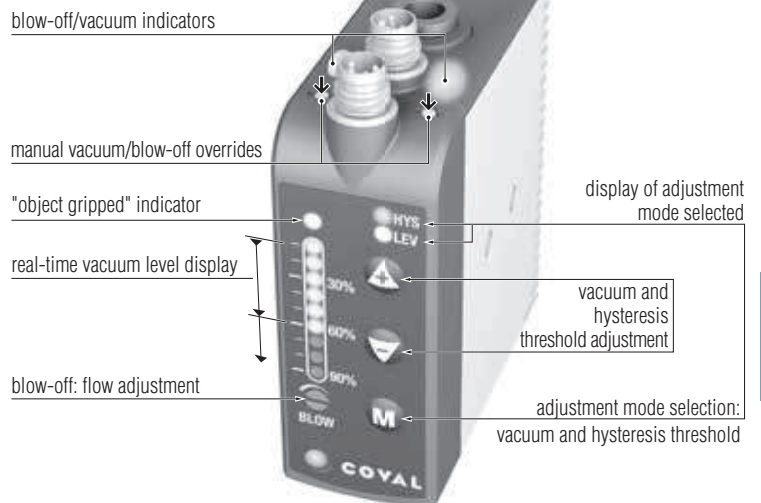

Mounting Options

Individual mountings, close to vacuum cups or compact island assembly.

side mounting



front mounting



over a DIN rail



island mounting





Stand-alone or Island Modules?

Stand-alone modules are suitable for the most common applications; one module controls one or more suction cups which all operate according to the same sequence. When several suction cups are operating according to different sequences, multiple modules are required, which can be:

- several stand-alone modules,
- an island of these modules with an internal common pressure unit.

The diagrams help in the selection:

- stand-alone modules are complete, with the integrated pressure regulator (**ASR**)
- in an island, the integrated regulator is absent: to maintain the advantage of economical and silent operation, it is recommended to reduce the pressure of the island's common pressure unit to 4 bar.

4.5 to 7 bar network pressure

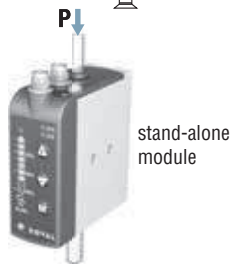
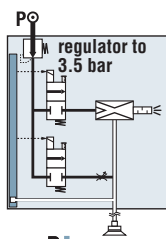

network pressure 4 bar

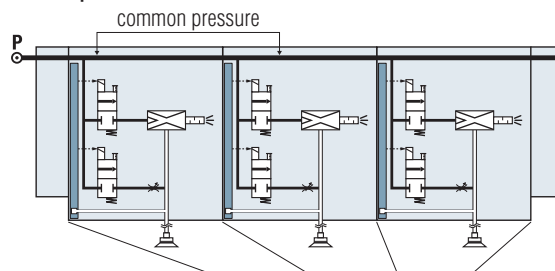

P optimal = 4 bar
(operation at 4-7 bar)



island of 3 modules supplying suction cups according to different sequences

Exhaust manifold: option E

The LEM mini vacuum pumps can be equipped with the "exhaust manifold" option, which provides a G1/8"-F connection to the exhaust in order to add a silencer, transfer the exhaust outside the work area or to avoid air discharge near the workpiece (LEM___E version).

This option must be specified at time of ordering as it cannot be added later.

Note: The design of the exhaust manifold and vacuum pumps do not guarantee the complete sealing of the exhaust and therefore cannot be used in a "clean room" environment.

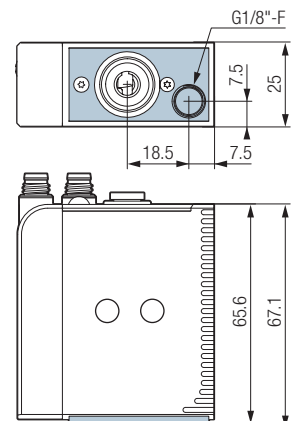
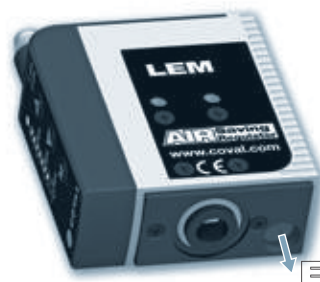



Stand-alone Modules



Side mounting

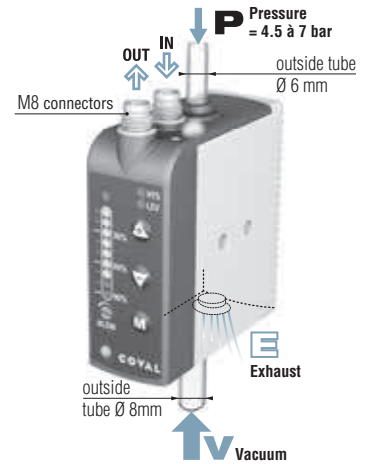
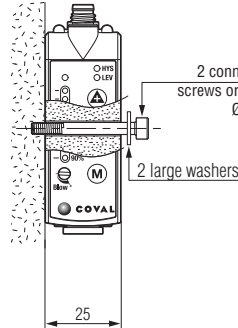
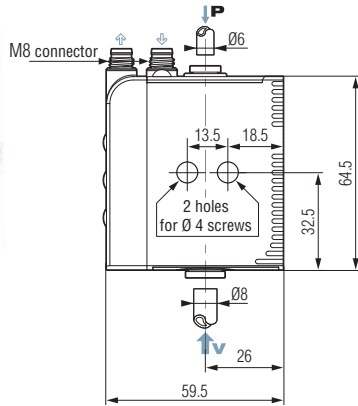

Front mounting

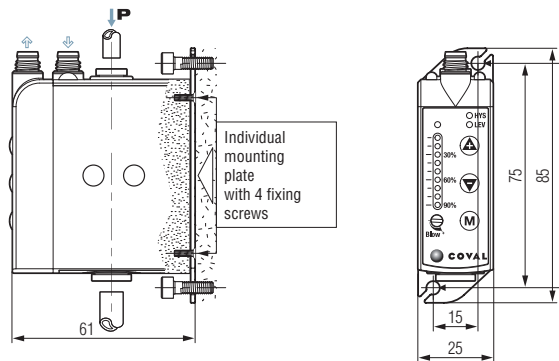

For front mounting, order the necessary kit, in addition to the module:

Front mounting kit:
1 plate + 4 screws

Part No.: LEMFIXA



Mounting on DIN rail

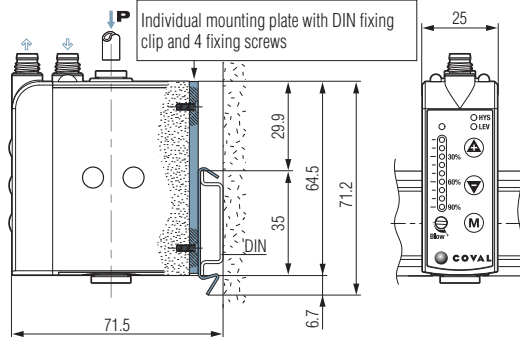

A module can be clipped onto a DIN rail. For this purpose, the module must first be equipped with an individual DIN installation plate, ordered separately:

DIN rail mounting kit:
1 plate/clip + 4 screws

Part No.: LEMFIXB

Islands

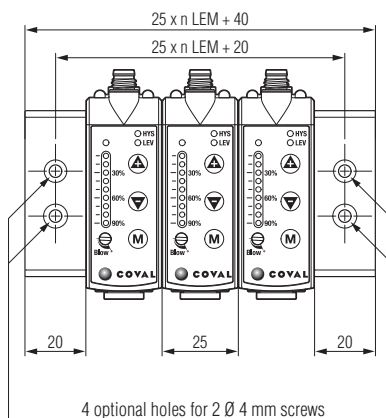

Front mounting

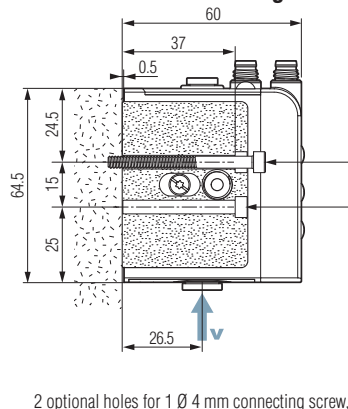

Mounting on DIN rail

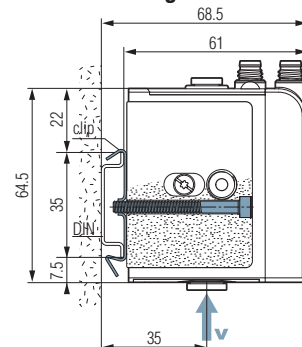

DIN rail mounting kit:
2 clips + 2 screws

Part No.: LEMFIXC



LEM: Versatile Series for all Applications

The opposite page demonstrates the versatility of this series. In addition to a very wide range of complete, stand-alone, or island vacuum pumps, there are the options of no blow-off and/or no vacuum switch, and for specific applications.

Select Vacuum Level and Nozzle Diameter

The introductory guide in this catalog shows that for porous objects, a 30-55% vacuum is economical and effective. This is obtained with a 60% maximum vacuum pump.

The table below helps to select the nozzle diameter which generates enough vacuumed air flow to respond in the time required by the application, based on a measurement of the material's leakage rate. On the contrary, with an airtight material, the vacuum used is 55% to 80%, obtained by a 85% max. vacuum pump.

- For standard cases, with its integrated blow-off, the LEMAX series is preferable, as it is more economical due to its ASC (Air Saving Control) function.
- For special cases, the LEM series contains versions without blow-off and versions without a vacuum switch. The table below helps to select the nozzle diameter required for the application.

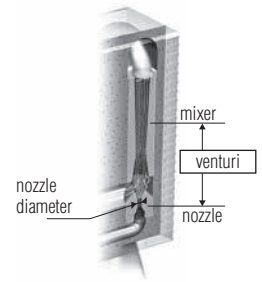

Porous materials:
cardboard, unfinished wood, pastries, etc.

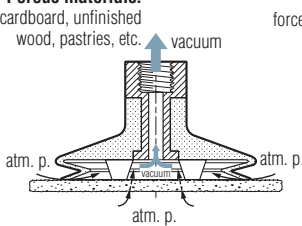

force generated by the vacuum

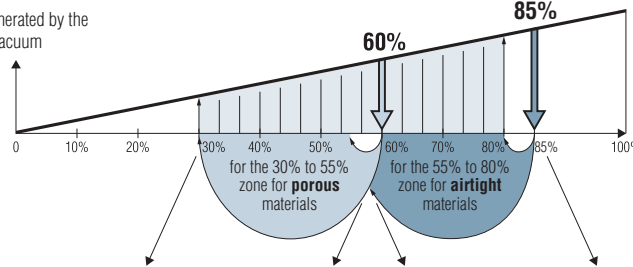

Airtight materials:
glass, plastic, sheet metal, finished wood

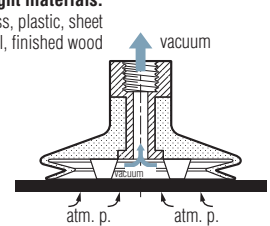

Porous Objects ▶ Maximum Vacuum Level: 60%

Time to create vacuum (seconds) for a volume of 1 liter

vacuum achieved	vacuum achieved						Air consumed (NI/min)	Air drawn in (NI/min)
	30%	35%	40%	45%	50%	55%		
ø nozzle								
1.0 mm	0.66	0.83	1.04	1.31	1.70	2.35	44	38
1.2 mm	0.41	0.52	0.66	0.83	1.07	1.49	65	72
1.4 mm	0.27	0.34	0.43	0.54	0.70	0.97	90	92

Airtight Objects ▶ Maximum Vacuum Level: 85%

Time to create vacuum (seconds) for a volume of 1 liter

vacuum achieved	vacuum achieved						Air consumed (NI/min)	Air drawn in (NI/min)
	55%	60%	65%	70%	75%	80%		
ø nozzle								
1.0 mm	1.76	2.04	2.38	2.80	3.33	4.09	44	29
1.2 mm	1.13	1.31	1.53	1.80	2.15	2.64	65	45
1.4 mm	0.73	0.85	0.99	1.16	1.38	1.70	90	70

Select Vacuum Controlled by NC or NO Solenoid Valve

Vacuum controlled by a NC (Normally Closed) solenoid valve remains the simplest standard option to use. In the event of an electricity shutoff, the vacuum is interrupted and the object is released.

Select vacuum controlled by NO (Normally Open) solenoid valve if the application requires holding the object in the event of an electricity shut-off. In this case, make sure to control the NO solenoid valve with the inverse signal of the "vacuum", which is noted as "vacuum".

signal controlled by NC solenoid valve

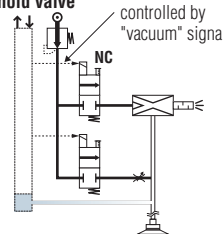

signal controlled by NO solenoid valve

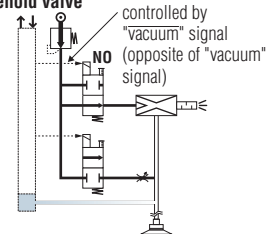

Select with or without Integrated Blow-off

Many applications require integrated blow-off. However, for some applications not requiring blow-off, a simplified version without blow-off is offered.

Select with or without Vacuum Switch

For common applications, the vacuum switch is needed, with the dialogue face for digital display and adjustment. However, some applications may just require a simple operation, without an "object gripped" return signal. The simplified version may then be chosen, with no vacuum switch, display, or adjustment.



Part numbers for an island assembly or components in an island

Part numbers for stand-alone units

LEM 60 X 12 S VA - B3

VACUUM LEVEL	
60% max. vacuum → porous objects	60
85% max. vacuum → airtight objects	90

NOZZLE DIAMETER	
Ø 1 mm nozzle	10
Ø 1.2 mm nozzle	12
Ø 1.4 mm nozzle	14

VACUUM SWITCH	
VA	Electronic vacuum switch with digital display and adjustment
VO	No vacuum switch and no adjustment

ISLAND ASSEMBLIES

B2		LEM_X..... B2 island assembly with 2 identical modules.
B3		LEM_X..... B3 island assembly with 3 identical modules.
B4	...	

If the planned island contains different module types, it must be ordered as separate components in order to then be assembled on site according to the arrangement suitable to the application.

COMPONENTS FOR THE ISLAND TO BE ASSEMBLED

B		LEM_X..... B Module that can be grouped (complete with integrated grouping screw)
		Set of ends for a complete group, with grouping screw and common pressure unit plug. PART NO.: LEMSETA

COMPOSITION OF THE MODULE

S	<ul style="list-style-type: none"> Vacuum controlled by NC solenoid valve → if the electricity is shut off, the vacuum is interrupted. Blow-off controlled by a specific signal
V	<ul style="list-style-type: none"> Vacuum controlled by NO solenoid valve → vacuum is maintained if electricity is shut off Blow-off controlled by a specific signal
R	<ul style="list-style-type: none"> Vacuum controlled by NC solenoid valve No blow-off
U	<ul style="list-style-type: none"> Vacuum controlled by NO solenoid valve No blow-off

EXHAUST	
Open (integrated silencer)	-
Exhaust manifold (G1/8"-F)	E

Additional options: On specific request:

- Modules with enhanced blow-off by integrated isolation valve.
- Modules with non-return valve will maintain vacuum in the event of loss of pneumatic and/or electrical power, during the grip cycle.

EXAMPLE COMPOSITE PART NUMBER FOR AN ISLAND ASSEMBLY:

LEM60X14SVAB3

LEM island assembly, containing 3 x 60% max. vacuum modules, Ø 1.4 mm nozzle, controlled by NC solenoid valve, blow-off and vacuum switch

ORDER EXAMPLE FOR AN ISLAND TO BE ASSEMBLED:

- LEM60X10VVAB
 - LEM90X12SVAB
 - LEM60X14SVAB
 - LEMSETA
- 3 LEM modules for a group, of different types.
- Set of ends for island.

REFERENCE EXAMPLE COMPOSED OF A STAND-ALONE MODULE:

LEM60X12SVA

Stand-alone LEM Module, 60% max. vacuum, Ø 1.2 mm nozzle, vacuum controlled by NC solenoid valve, blow-off and vacuum switch.

Integrated Mini Vacuum Pumps with ASR Characteristics / Assembling an Island



ASR Saving Regulator

Overall Characteristics

- Supply: non-lubricated air filtered to 5 microns according to standard ISO 8573-1:2010 [4:5:4].
- Operating pressure: 4.5 to 7 bar.
- Mini dynamic pressure: - stand-alone module: P = 4.5 bar.
- island modules: 4 bar.
- Blow-off: adjustable flow: - stand-alone version: P = 3.5 bar.
- island version: P network.
- Maximum vacuum: 60% or 85% depending on model.
- Suction rate: 29 to 92 NI/min depending on model.
- Air consumption: 44 to 90 NI/min depending on model.
- Electrical protection level: IP 65.
- Control voltage: 24 V DC (regulated $\pm 10\%$).
- Current draw: 30 mA (0.7 W) vacuum or blow-off.
- Max. operating frequency: 4 Hz.
- Endurance: 30 million cycles.
- Weight: 90 to 120 g, depending on model.
- Operating temperature: 0 to 50 °C.
- Materials: PA 6-6 15 %FV, brass, aluminum, NBR.

Integrated Vacuum Switch Characteristics

- Measuring range: -1 to 0 bar.
- Precision: $\pm 1.5\%$ of the range.
- Hysteresis: adjustable from 0% to 100%.
- Output threshold: 1 x T.O.R. in NO.
- Analog output: 1 V DC to 5 V DC on the measuring range.
- Switching power: 125 mA, PNP.
- Threshold status display: 1 green LED.
- Supply voltage 24V DC (regulated $\pm 10\%$).
- Current draw: < 20 mA.
- Protection: against polarity inversions.

Characteristics and Connecting an Island

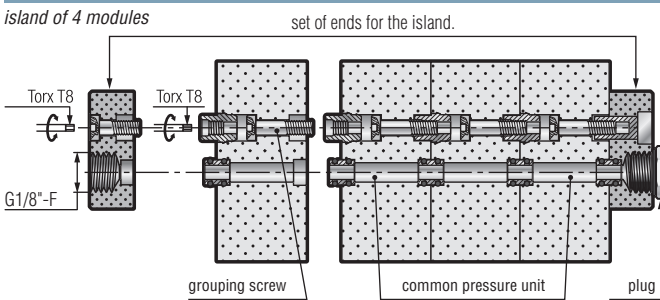

island of 3 modules



Maximum number of modules in an island:

- $\varnothing 1.4$ mm nozzle \rightarrow 5 modules
- $\varnothing 1.2$ mm nozzle \rightarrow 7 modules
- $\varnothing 1$ mm nozzle \rightarrow 9 modules

Integrated Silencer Characteristics

- Noise level: approximately 68 dBA.
- Clog-free silencer.

Electrical Connections

MODULES WITHOUT VACUUM SWITCH FUNCTION

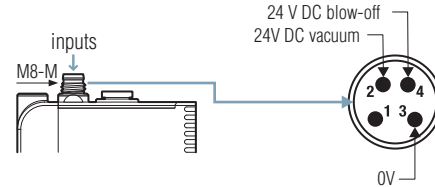

MODULES WITH VACUUM SWITCH FUNCTION

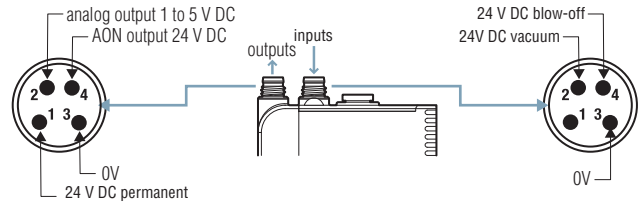

Accessories

- Power supply cable M8, straight, female, 4-pin – open end:
 - **CDM8**: length. 2 m.
 - **CDM8N**: length. 0.5 m.
- Power supply cable M8, elbow, female, 4-pin – open end:
 - **CCM8**: length. 2 m.

Suction Flow Rate / Vacuum Curves

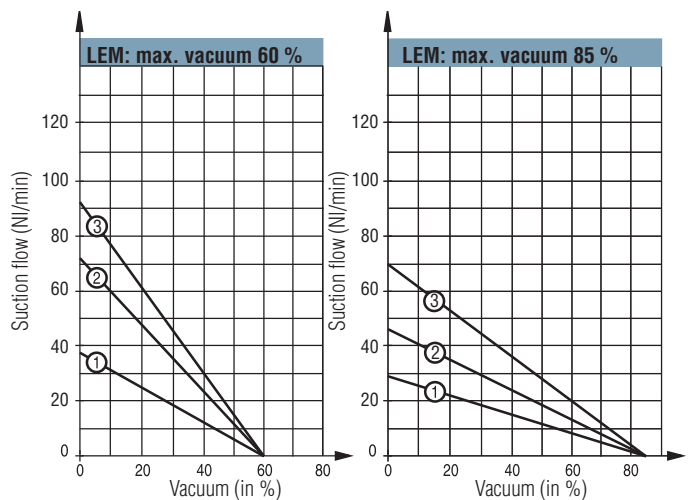

- 1 - LEM60X10
- 2 - LEM60X12
- 3 - LEM60X14

- 1 - LEM90X10
- 2 - LEM90X12
- 3 - LEM90X14

Note: in the same island, it is possible to combine LEM series modules and LEMAX series modules.

LEMAX

Integrated Mini Vacuum Pumps with "ASC" (Air Saving Control)



AIR Saving Control

Industry-specific applications



For all objects, airtight or not very porous



Advantages

- Energy savings of 75% to 99% (depending on application) thanks to automatic **ASC** (Air Saving Control) operation.
- "All-in-one" solution, no more peripherals to be added.
- Simplified installation and use thanks to the Plug & Play system.
- Unmatched compactness: installation close to suction cups → short response times and energy savings.
- No clogging, thanks to the through-type silencer.
- Controlled or timed blow-off.
- Gripping safety in the event of electricity shut-off.
- Smart communication → Easier experience at all stages: initial settings, production, maintenance.

Compact Integration

The illustrations below demonstrate the 9 functions integrated in the mini-module, and their respective roles in operation.

The result of this COVAL performance is:

- **A mini module** (≅ 130 g) that is easy to install close to the suction cups, reducing the volume to be evacuated → increased speed and energy savings.
- **A complete module**, therefore not requiring any additional function or connections.

The **LEMAX** compact modules integrate all the functions of "industrial vacuum" including simple, efficient, economical compressed air usage and are adapted for every application:

- 1 3.5 bar pressure regulator
- 2 Solenoid valve "vacuum"
- 3 3.5 bar optimized Venturi
- 4 Through-type silencer
- 5 Electronic vacuum switch
- 6 Integrated electronics
- 7 Solenoid valve "blow-off"
- 8 Blow-off flow adjustment
- 9 Check valve on vacuum

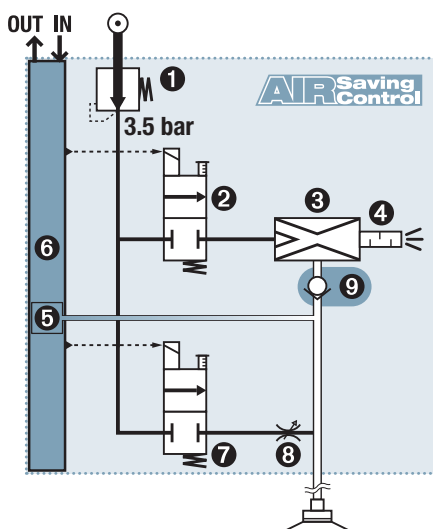

Combination of non-return 9 and advanced electronics 6 ensures the **ASC's** automatic performance.

→ **Once desired vacuum level is reached, the LEMAX no longer consumes air when gripping the product.**

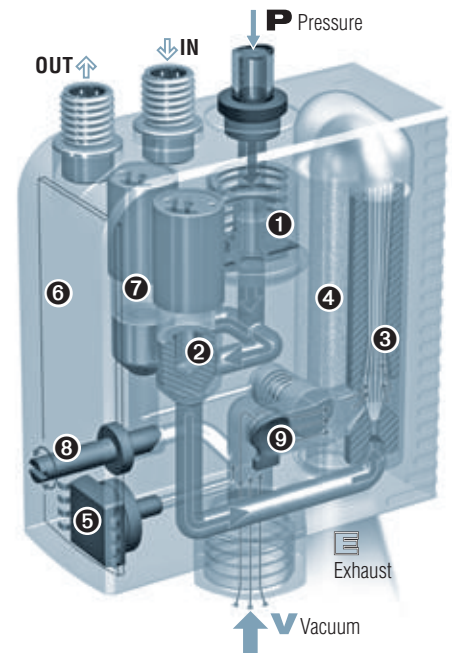

Schematic representation

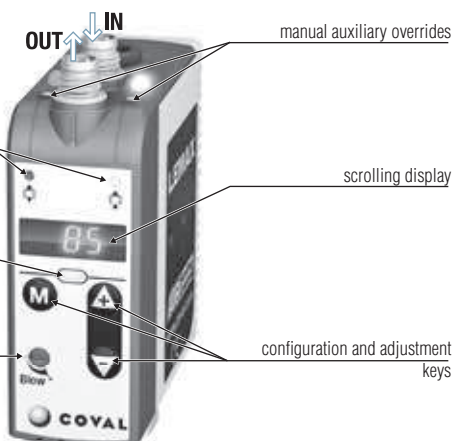

LEMAX 8

AIR Saving Control

90% energy savings (on average).

Smart Communication

The adjacent illustration presents the display panel which enables:

- Initial settings
- Any adjustments
- Production monitoring
- Maintenance

In particular, the no "**ASC**" alert, (see next page), helps to start maintenance operations in order to return to "**ASC**" operation, which is especially energy-saving.



"Air Saving Control" Cycle

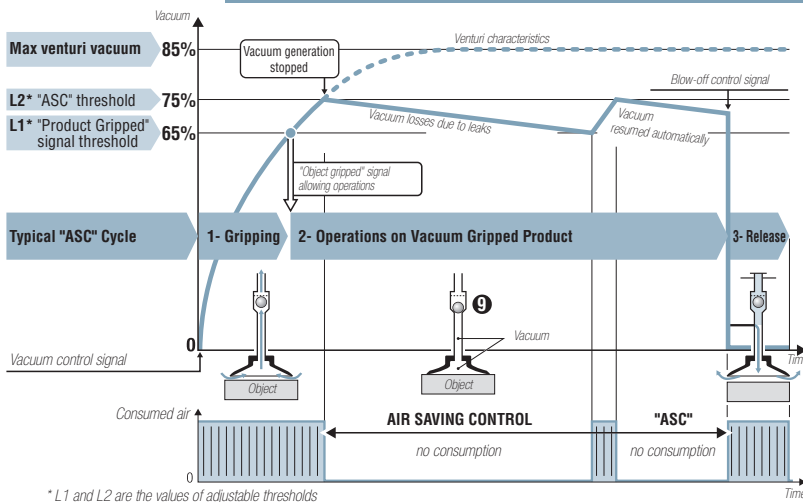

As illustrated above, the LEMAX module automatically executes the "ASC" cycle, thus saving the maximum amount of energy, based on the following 3 phases.

1- Gripping the object

The "vacuum" solenoid starts the cycle by supplying the venturi which generates the vacuum to quickly pick up the object with the suction cup → short-term consumption.

2- Operations on the object held by vacuum

The vacuum level is constantly monitored by the vacuum switch. When it reaches the L1 threshold (65%), the "gripped object" signal is generated, which allows the planned operations (transfer, machining, etc.). When the vacuum reaches threshold L2 (75%), the supply to the venturi via the solenoid valve is cut off → consumption is halted. The object remains held by the retained vacuum thanks to the closed valve. Micro-leaks will generally cause the vacuum level to fall slowly. Each time it falls below 65%, vacuum generation is briefly resumed until it reaches threshold L2 (75%).

3- Releasing the object

At the end of operations, blow-off is ordered. The "blow-off" solenoid valve generates a stream of air which closes the isolation valve, blows on the object to release it quickly.

Smart Adaptation

The illustration below shows the adaptation capacities of the LEMAX module. "ASC" operation is automatic for any object that is airtight enough (cycle 1). If a leak occurs (cycle 2), due to a rough object or to suction-cup wear, the module automatically detects the anomaly, ends the cycle without "ASC" in order to continue production and reports the event for possible maintenance. Production continues. Once everything is returned to normal (cycle 3), "ASC" operation is automatically resumed.

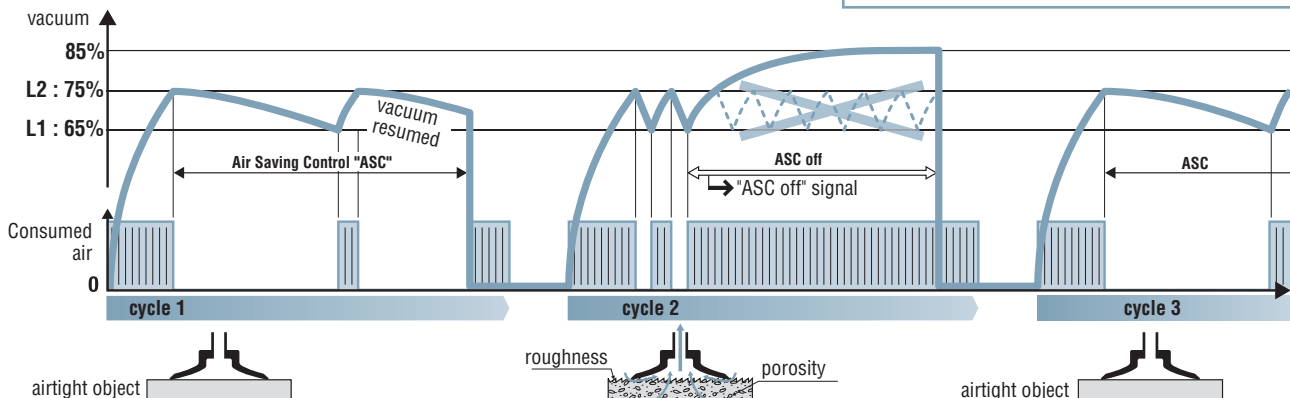

1- Gripping + Transfer (Ø 1.4 mm nozzle, 0.2 l of vacuum)

Phase	Duration	Air consumption		Energy savings achieved
		"ASC" off	"ASC" on	
Gripping	0.28 s	0.4 NI	0.4 NI	75 %
Transfer	1.20 s	1.8 NI	0	
Release	0.14 s	0.2 NI	0.2 NI	
		2.4 NI	0.6 NI	

2- Clamping + Operations (Ø 1.4 mm nozzle, 0.4 l of vacuum)

Phase	Duration	Air consumption		Energy savings achieved
		"ASC" off	"ASC" on	
Clamping	0.55 s	0.8 NI	0.8 NI	99 %
Operations	60 s	90 NI	0	
Release	0.14 s	0.2 NI	0.2 NI	
		91 NI	1.0 NI	

Resulting savings

Energy savings from "ASC" are major, as the two examples opposite above:

- 75% savings for transferring an object after gripping.
- 99% savings for holding an object during a 1 minute operation.

The investment generally pays for itself in just a few months.

"ASC": AN ADVANTAGE WITHOUT LIMITATIONS

Saving energy has become essential. With LEMAX, thanks to "ASC", energy is automatically saved without interfering with established operations:

- 1- No specific adjustment:** The initial setting (L1 = 65%, L2 = 75%) is suitable for most applications.
- 2- Production regardless of what happens:** Operation is always ensured, if necessary without "ASC", if the leakage level is too high.
- 3- Guided maintenance:** Clear display of the need for maintenance to return to auto-regulated "ASC" operation.



The LEMAX vacuum pumps, which integrate an ASR "venturi regulator" combination, share values that COVAL values greatly: they greatly reduce the volume of compressed air consumption and noise level.



Suction Flow Rate / Vacuum Curves

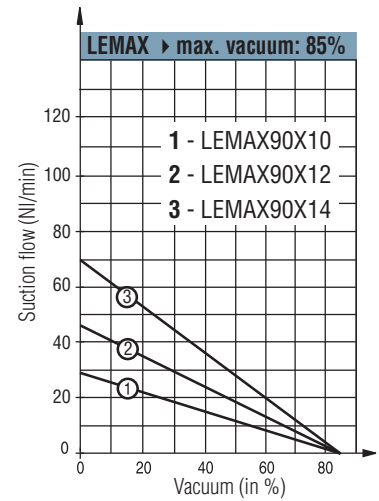

Power Determined by the Venturi Nozzle Diameter

The table shows the power levels generated by each of the nozzle diameters available: when the module is operating with "ASC" off, a larger nozzle draws and consumes more compressed air.

On the other hand, during "ASC" operation, a large nozzle quickly reaches the vacuum threshold generating power shut-off.

In conclusion:

- A large nozzle enables quicker gripping without consuming more during "ASC" operation.
- A small nozzle consumes less only when operating continues without "ASC".

Selecting the Nozzle Diameter

Ø nozzle	Venturi characteristics during "ASC off" operation.		"ASC" operation - gripping at 65% vacuum - vacuum shutoff at 75% Time for a volume of 1l		
	air drawn in (NI/min)	air consumed (NI/min)	grip time (s) (65% vacuum)	time (s) up to 75% vacuum	air consumed (NI)
1.4 mm	70	90	0.99	1.38	2.2
1.2 mm	45	65	1.53	2.15	2.2
1.0 mm	29	44	2.38	3.33	2.2



Select Vacuum Controlled by NC or NO Solenoid Valve

Vacuum controlled by a NC (Normally Closed) solenoid valve remains the simplest standard option to use. In the event of an electricity shutoff, the vacuum is interrupted and the object is released. On the contrary, with vacuum control by NO (Normally Open) solenoid valve, the vacuum continues to be generated in the event of an electrical shutoff: positive object-holding security.

The diagrams opposite show that both versions are controlled by the same "vacuum" signal ν :

- NC version, the signal ν controls the vacuum generation.
- NO version, the signal ν controls the vacuum shutdown.

Note, however, that the NO version requires blow-off controlled by a specific signal: automatic, timed blow-off can only be configured in the NC version.

NC solenoid valve

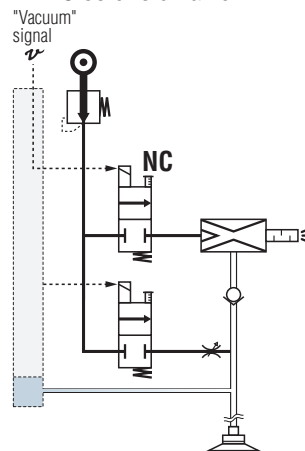

NO solenoid valve

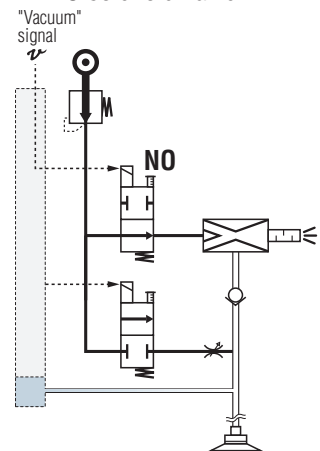

Stand-alone or Island Modules?

Stand-alone modules are suitable for the most common applications: one module controls one or more suction cups which all operate according to the same sequence.

When several suction cups are operating according to different sequences, multiple modules are required, which can be:

- several autonomous modules;
- a group of these modules with an internal common pressure unit.

The illustrations opposite guide the selection:

- stand-alone modules are coupled with integrated pressure regulators (ASR)
- in an island, the integrated regulator is removed: to maintain the advantage of economical and silent operation, it is recommended to reduce the island's common pressure supply pressure to 4 bar.

Network pressure:
4.5 to 7 bar

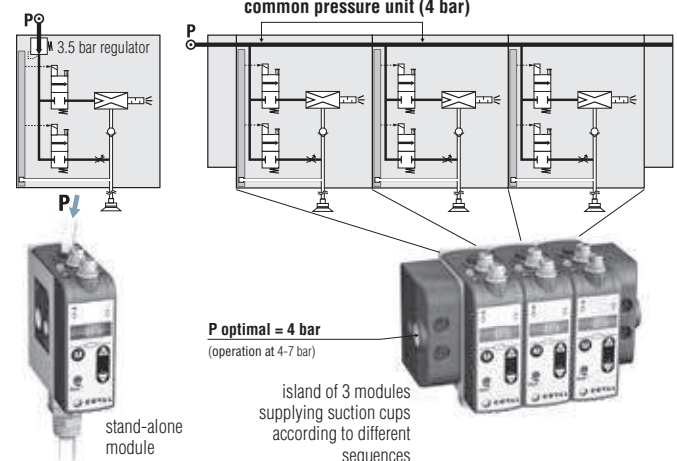

Integrated Mini Vacuum Pumps with "ASC" Configuring a Vacuum Pump



AR Saving Control

Part numbers for an island assembly or components in an island

Part numbers for stand-alone units

LEM **MAX** **90** **X** **14** **S** - - **B3**

VACUUM LEVEL

maximum 85%
vacuum optimum for
airtight objects **90**

NOZZLE DIAMETER

Ø 1.4 mm nozzle	14
Ø 1.2 mm nozzle	12
Ø 1 mm nozzle	10

COMPOSITION OF THE MODULE

Vacuum pump controlled by a Normally Closed (NC) solenoid valve

LEM90X...S...

- In the event of an electrical shut-off, vacuum is no longer generated.
- Optional configured blow-off:
 - by specific signal,
 - automatic, timed 0 to 9.9 sec. (→ a single control signal vacuum and blow-off).

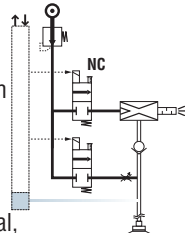

Vacuum pump controlled by a Normally Open (NO) solenoid valve

LEM90X...V...

- In the event of an electrical shut-off, the vacuum continues to be generated: gripped object held → positive security.
- Blow-off controlled by a specific signal.

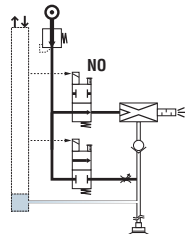

CONNECTORS

- Vacuum Pump with 2 M8 4-pin Connectors LEM90X...



- Discrete I/O.
- "Gripped product" switching output 24V DC / NO.
- 1 configurable auxiliary output:
 - either "Vacuum level" signal analogic 1 to 5V DC.
 - or "Without ASC" signal +5V DC switching output NO.

C14 Vacuum Pump with 1 M8 4-pin Connector LEM90X...SC14 (S version only)



- "Gripped product" switching output 24V DC / NO.
- Automatic blow-off, timed 0 to 9.9 sec.

EXHAUST

Open (integrated silencer)	-
Exhaust manifold (G1/8"-F)	E

ISLAND ASSEMBLIES

B2 LEM90X...B2 island assembly with 2 identical modules.



B3 LEM90X...B3 island assembly with 3 identical modules.



B4 ...

If the planned island contains different module types, it must be ordered as separate components in order to then be assembled on site according to the arrangement suitable to the application.

COMPONENTS FOR THE ISLAND TO BE ASSEMBLED

B LEMAX...B Module that can be grouped (complete with integrated grouping screw).



Set of ends for a complete island, with grouping screw and common pressure unit plug.



PART NO.: LEMSETA

Input/Output switching type can be set to PNP/NPN

REFERENCE EXAMPLE COMPOSED OF A STAND-ALONE MODULE:

- **LEM90X14S**
LEM90X, mini vacuum pump, 85% max. vacuum, 1.4 mm nozzle, controlled by a NC (Normally Closed) solenoid valve.

EXAMPLE COMPOSITE PART NUMBER FOR AN ISLAND ASSEMBLY:

- **LEM90X14SB3**
LEM90X group assembly, containing 3 x 85% max. vacuum modules, Ø 1.4 mm nozzle, controlled by NC (Normally Closed) solenoid valve.

ORDER EXAMPLE FOR AN ISLAND TO BE ASSEMBLED:

- **LEM90X14VB**
 - **LEM90X12SB**
 - **LEM90X10VB**
 - **LEMSETA** → Set of ends for island.
- 3 LEMAX modules for an island, of different types.

Integrated Mini Vacuum Pumps with "ASC"

Dimensions, Mounting Options



Exhaust manifold: option E

The LEMAX mini vacuum pumps can be equipped with the "exhaust manifold" option, which provides a G1/8"-F connection to the exhaust in order to add a silencer, transfer the exhaust outside the work area or to avoid air discharge near the workpiece (LEMAX___E version).

This option must be specified at time of ordering as it cannot be added later.

Note: The design of the exhaust manifold and vacuum pumps do not guarantee the complete sealing of the exhaust and therefore cannot be used in a "clean room" environment.

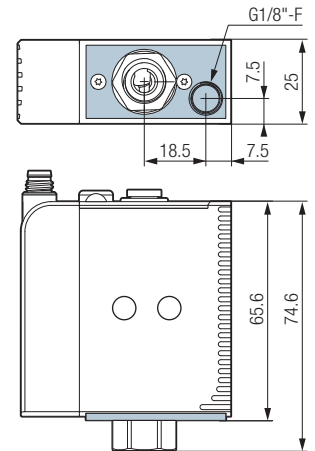

Stand-alone Modules



Side mounting

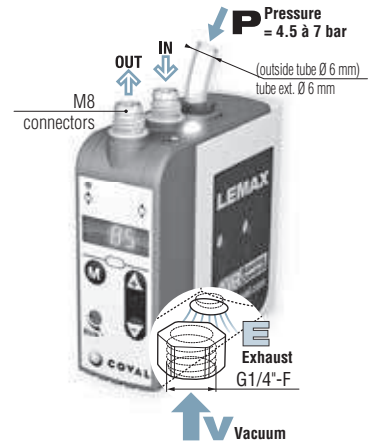
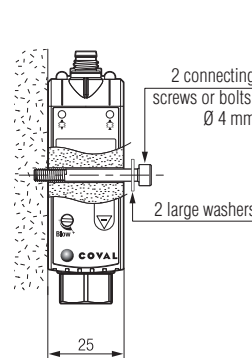
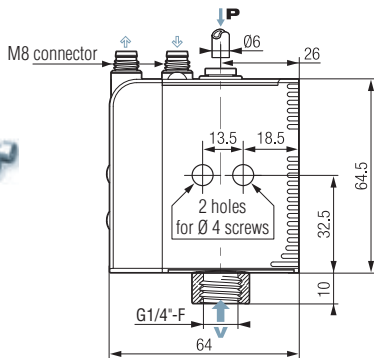

Front mounting

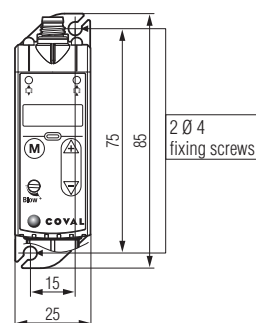
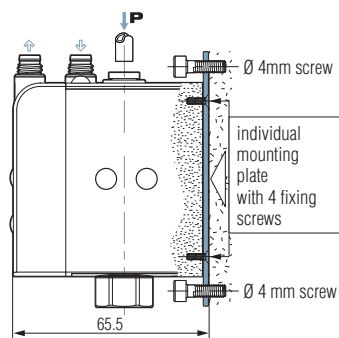

For front mounting, order the necessary kit, in addition to the module:

Front mounting kit:
1 plate + 4 screws

Part No.: LEMFIXA

A module can be clipped onto a DIN rail. For this purpose, the module must first be equipped with an individual DIN installation plate, ordered separately:

DIN rail mounting kit:
1 plate/clip + 4 screws

Part No.: LEMFIXB



Mounting on DIN rail

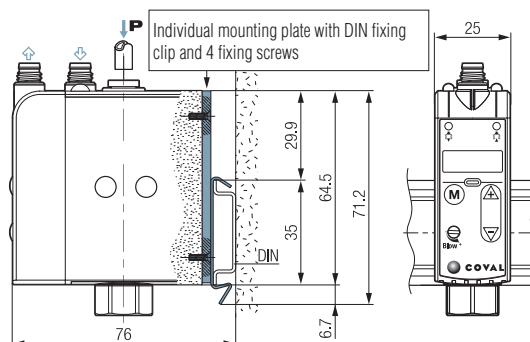



Islands

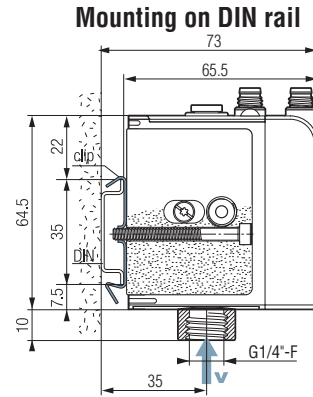
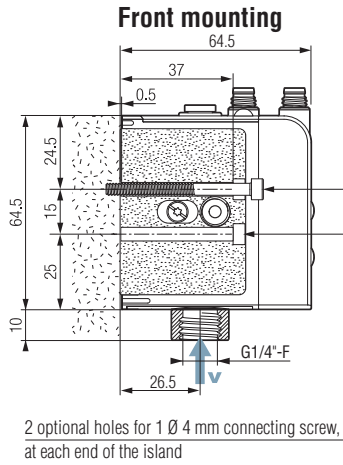
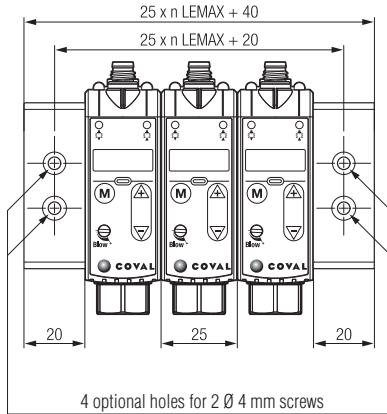

DIN rail mounting kit: 2 clips + 2 screws

Part No.: LEMFIXC

Assembling and Connecting an Island

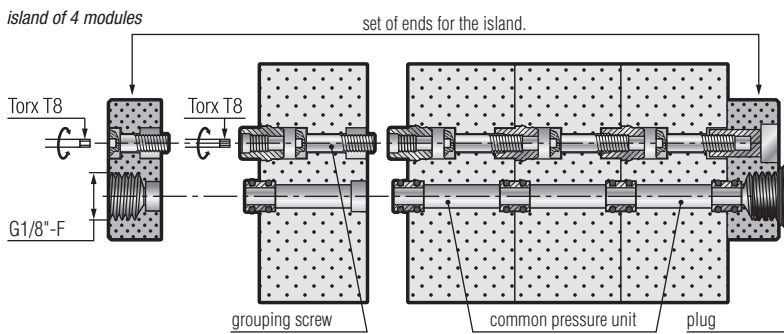

island of 3 modules



Maximum number of modules in an island:

- Ø 1.4 mm nozzle → 5 modules
- Ø 1.2 mm nozzle → 7 modules
- Ø 1 mm nozzle → 9 modules

Note:

In a single island, it is possible to combine LEMAX series modules and LEM series modules.



For NC Vacuum Pumps with 2 M8 4-pin connectors, model LEMAX90X..S..

configurable auxiliary output

- "vacuum level" signal analog, 1 to 5 VDC
- ↓ OR (configuration)
- ASC off signal +5 V TOR in NO

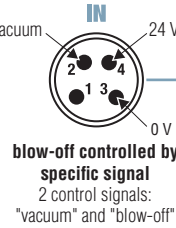
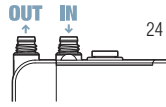
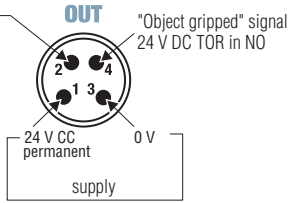

OR (setting)

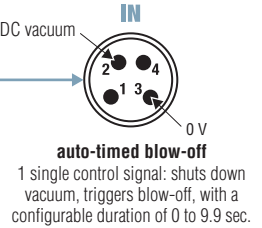

For NO Vacuum Pumps with 2 M8 4-pin connectors, model LEMAX90X..V..

configurable auxiliary output

- "vacuum level" signal analog, 1 to 5 VDC
- ↓ OR (configuration)
- ASC off signal +5 V TOR in NO

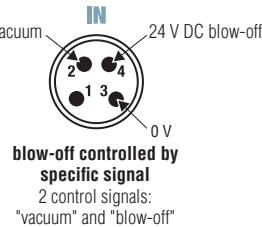
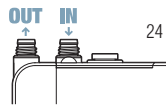
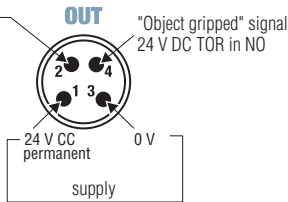

For NC Vacuum Pumps with 1 M8 4-pin connector, model LEMAX90X..SC14

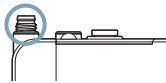
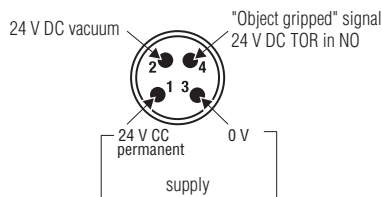

8

LEMAX

Accessories



Power supply cable M8, straight, female, 4-pin – open end:

- **CDM8**: length. 2 m.
- **CDM8N**: length. 0.5 m.

Power supply cable M8, elbow, female, 4-pin – open end:

- **CCM8**: length. 2 m.

Accessory

Protection for standalone mini-vacuum pumps LEMAX__SC14
(with one M8 connector), Part No.: 80004409

The COVER is made of silicone and serves as a protective sleeve for vacuum pumps, protecting them against splashing water, in particular during cleaning cycles.

- High level of protection against splashing water
- Easy to mount and clean





ASR Saving Control

Overall Characteristics

- Supply: non-lubricated air filtered to 5 microns according to standard ISO 8573-1:2010 [4:5:4].
- Operating pressure: 4.5 to 7 bar.
- Mini dynamic pressure:
 - stand-alone version: P = 4.5 bar.
 - island version: P = 4 bar.
- Blow-off: adjustable flow:
 - stand-alone version: P = 3.5 bar.
 - island version: P network
- Maximum vacuum: 85%
- Suction rate: 29 to 70 NI/min.
- Air consumption: 44 to 90 NI/min during "ASC" off operation
- Integrated clog-free silencer.
- Noise level: approximately 68 dBA "ASC" off. 0 dBA with "ASC".
- Electrical protection level: IP 65.
- Max. operating frequency: 4 Hz.
- Endurance: 30 million cycles.
- Weight: 130 g.
- Operating temperature: 0 to 50 °C.
- Materials: PA 6-6 15%FV, brass, aluminum, NBR.

Electrical controls

- Control voltage: 24 V DC (regulated $\pm 10\%$), PNP or NPN.
- Current draw: 30 mA (0.7 W) vacuum or blow-off.

Integrated electronics

- Power supply 24 V; current draw: <57mA.
- Measuring range: 0 to 99% vacuum.
- Measuring precision: $\pm 1.5\%$ of the range, compensated in temperature.
- Display: 3 digits, 7 segments.

Service Characteristics

"Object gripped" output signal

- 24 VDC, switching output / NO, switching power: 125 mA PNP or NPN.

Configurable auxiliary output, choose either of the following (not available for version LEMAX90X_**SC14**):

- "vacuum level" signal, analog 1 to 5 V DC of the measuring range.
- "ASC" off signal, +5 V switching output / NO.

Input/Output switching type

- can be set to PNP (by default) or NPN.

Displays

- Scrolling display: 3 digits, 7 segments.
- Flashing if "ASC" off for maintenance.
- Status indicators: "Vacuum," green LED, "blow-off," red LED.
- "Object gripped" indicator: Green LED on front panel.

Configurations

- By mechanical keys and drop-down menu.
- Measurement unit selection (% , mbar, inHg).
- Choice of blow-off type:
 - LEMAX90X_**S**_ version: controlled by a specific signal or automatic and adjustable from 0 to 9.9 s.
 - LEMAX90X_**V**_ version: controlled by a specific signal.
 - LEMAX90X_**SC14** version: automatic and adjustable from 0 to 9.9 s.

Settings

- Display of the number of cycles (vacuum cycle counter).
- If the application so requires, specific adjustment of thresholds and hysteresis different to original factory settings (L1=65% h1=10%, L2=75%, h2=10%).

Autoreactivity

- Constant monitoring of leakage rate: abandon or automatic return to "ASC" operation.

LEMAX IO

Mini Vacuum Pumps with Communication IO-Link

General Information



Industry-specific applications

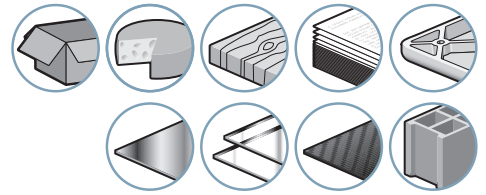

Advantages

- Easy installation and operation thanks to the IO-Link communication interface.
- Energy savings of 75% to 99% (depending on application) thanks to automatic **ASC** (Air Saving Control) operation.
- "All-in-one" solution, no more peripherals to be added.
- Unmatched compactness: installation close to suction cups → short response times and energy savings.
- No clogging, thanks to the through-type silencer.
- Controlled or timed blow-off.

Compact Integration

The illustrations below show the 9 functions integrated into the mini-module, and their respective roles in operation. The result of this COVAL performance is:

- **A mini module** (≅ 130 g) that is easy to install close to the suction cups, reducing the volume to be evacuated → increased speed and energy savings.
- **A complete module**, therefore not requiring any additional function or connections.

The **LEMAX IO** compact modules integrate all the functions of "industrial vacuum" including simple, efficient, economical compressed air usage and are adapted for every application:

- 1 3.5 bar pressure regulator
- 2 Solenoid valve "vacuum"
- 3 3.5 bar optimized Venturi
- 4 Through-type silencer
- 5 Electronic vacuum switch
- 6 Integrated electronics
- 7 Solenoid valve "blow-off"
- 8 Blow-off flow adjustment
- 9 Check valve on vacuum

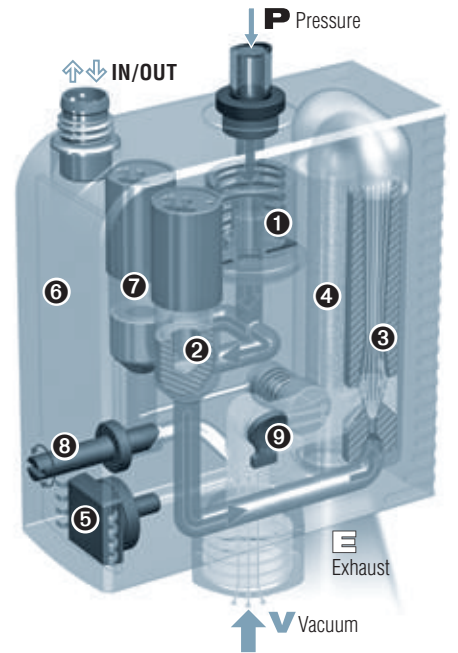
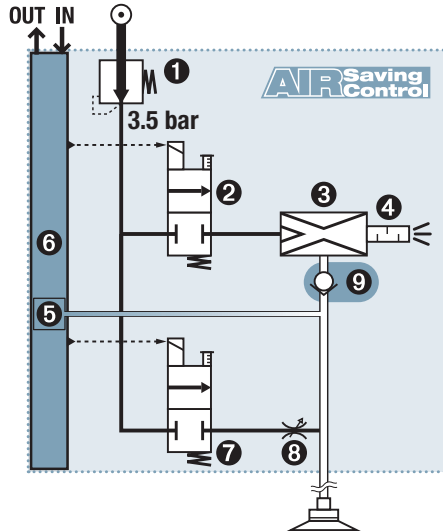

Schematic representation

Combination of non-return 9 and advanced electronics 6 ensures the **ASC's** automatic performance.
 → **Once desired vacuum level is reached, the LEMAX IO no longer consumes air when gripping the product.**



90% energy savings (on average)

LEMAX IO 8



The IO-Link system provides efficient real-time communication between LEMAX IO vacuum pumps and any higher-level protocol (EtherNet/IP, PROFINET, EtherCAT, etc.) required to monitor the production line. It can be used to control pumps, configure settings, and get feedback to ensure maximum productivity.

Advantages:

- Straightforward wiring, installation, and setup
- Availability of diagnostic status data
- Simpler preventive maintenance and vacuum pump replacement without manual setup, and more

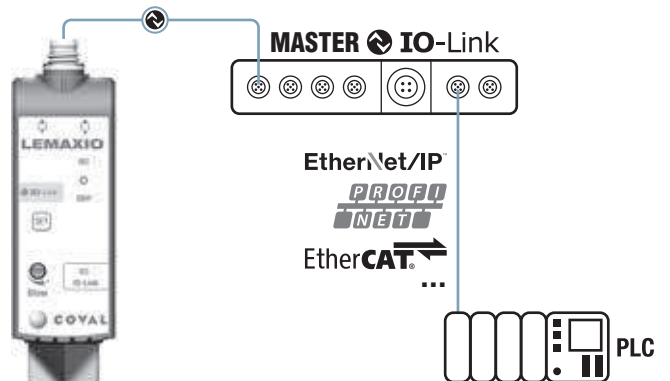

LEMAX IO

Mini Vacuum Pumps with Communication IO-Link Energy Savings



AIR Saving Control

IO-Link



"Air Saving Control" Cycle

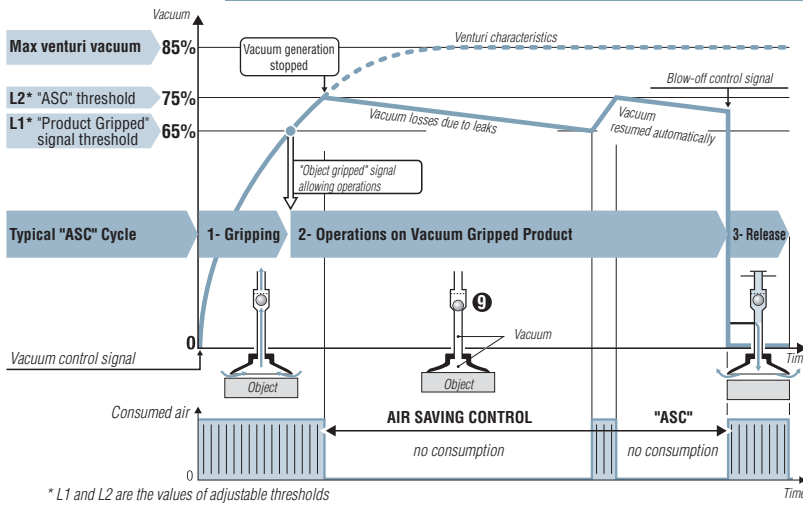

As illustrated above, the LEMAX IO module automatically executes the "ASC", cycle, thus saving the maximum amount of energy, based on the following 3 phases.

1- Gripping the object

The "vacuum" solenoid starts the cycle by supplying the venturi which generates the vacuum to quickly pick up the object with the suction cup → short-term consumption.

2- Operations on the object held by vacuum

The vacuum level is constantly monitored by the vacuum switch. When it reaches the L1 threshold (65%), the "gripped object" signal is generated, which allows the planned operations (transfer, machining, etc.). When the vacuum reaches threshold L2 (75%), the supply to the venturi via the solenoid valve is cut off → consumption is halted. The object remains held by the retained vacuum thanks to the closed valve. Micro-leaks will generally cause the vacuum level to fall slowly. Each time it falls below 65%, vacuum generation is briefly resumed until it reaches threshold L2 (75%).

3- Releasing the object

At the end of operations, blow-off is ordered. The "blow-off" solenoid valve generates a stream of air which closes the isolation valve, blows on the object to release it quickly.

Smart Adaptation

The illustration below shows the adaptation capacities of the LEMAX IO module. "ASC" operation is automatic for any object that is airtight enough (cycle 1). If a leak occurs (cycle 2), due to a rough object or to suction-cup wear, the module automatically detects the anomaly, ends the cycle without "ASC" in order to continue production and reports the event for possible maintenance. Production continues. Once everything is returned to normal (cycle 3), "ASC" operation is automatically resumed.

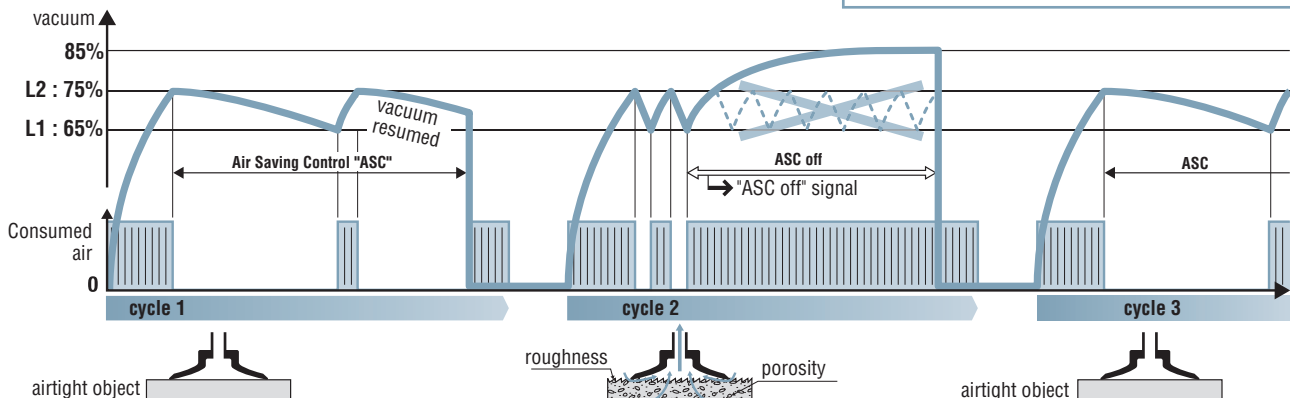

1- Gripping + Transfer (Ø 1.4 mm nozzle, 0.2 l of vacuum)

Phase	Duration	Air consumption		Energy savings achieved
		"ASC" off	"ASC" on	
Gripping	0.28 s	0.4 NI	0.4 NI	75 %
Transfer	1.20 s	1.8 NI	0	
Release	0.14 s	0.2 NI	0.2 NI	
		2.4 NI	0.6 NI	

2- Clamping + Operations (Ø 1.4 mm nozzle, 0.4 l of vacuum)

Phase	Duration	Air consumption		Energy savings achieved
		"ASC" off	"ASC" on	
Clamping	0.55 s	0.8 NI	0.8 NI	99 %
Operations	60 s	90 NI	0	
Release	0.14 s	0.2 NI	0.2 NI	
		91 NI	1.0 NI	

Resulting savings

Energy savings from "ASC" are major, as the two examples opposite above:

- 75% savings for transferring an object after gripping.
- 99% savings for holding an object during a 1 minute operation.

The investment generally pays for itself in just a few months.

"ASC": AN ADVANTAGE WITHOUT LIMITATIONS

Saving energy has become essential. With LEMAX IO, thanks to "ASC", energy is automatically saved without interfering with established operations:

- 1- No specific adjustment:** The initial setting (L1 = 65%, L2 = 75%) is suitable for most applications.
- 2- Production regardless of what happens:** Operation is always ensured, if necessary without "ASC", if the leakage level is too high.
- 3- Guided maintenance:** Clear display of the need for maintenance to return to auto-regulated "ASC" operation.



The LEMAX IO vacuum pumps, which integrate an ASR "venturi regulator" combination, share values that COVAL values greatly: they greatly reduce the volume of compressed air consumption and noise level.

LEMAX IO

Mini Vacuum Pumps with Communication IO-Link Communication / Selection Guide



AIR Saving Control

IO-Link



Communication HMI / IO-Link

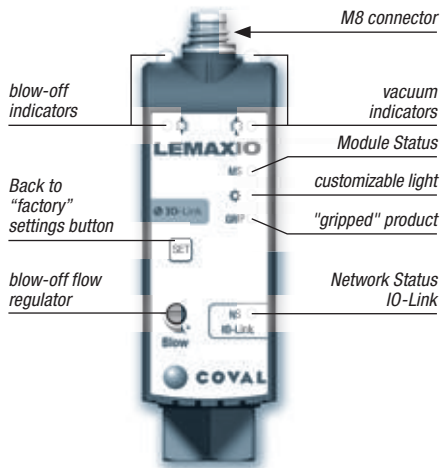

Settings, Diagnostics, and Process Data

CONFIGURABLE SETTINGS

- "Object gripped" and ASC control thresholds.
- ASC vacuum control system management.
- Automatic blow-off.
- Configurable LED.

DIAGNOSTICS

- Cycle counters (vacuum and blow-off control, objects gripped, objects lost, etc.)
- Monitoring of the supply voltage.
- Software version.
- Product number and serial number.

PROCESS INPUT DATA

- Vacuum and blow-off control.

PROCESS OUTPUT DATA

- Instantaneous vacuum level.
- Object gripped and object lost information.
- Status of ASC vacuum regulation system.
- Alarms (high / low voltage).

Power Determined by the Venturi Nozzle Diameter

Selecting the Nozzle Diameter

Ø nozzle	Venturi characteristics during "ASC off" operation.		"ASC" operation - gripping at 65% vacuum - vacuum shutoff at 75% Time for a volume of 1l		
	air drawn in (NI/min)	air consumed (NI/min)	grip time (s) (65% vacuum)	time (s) up to 75% vacuum	air consumed (NI)
1.4 mm	70	90	0.99	1.38	2.2
1.2 mm	45	65	1.53	2.15	2.2
1.0 mm	29	44	2.38	3.33	2.2



Suction Flow Rate / Vacuum Curves

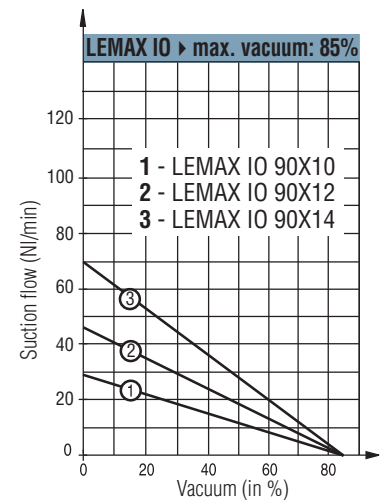

LEMAX IO 8

Electrical Connections



Pin	Designation	Function	Wire
1	24 V DC	L+	Brown
2	/	/	White
3	0 V - GND	L-	Blue
4	IO-Link communication line	C/Q	Black

Note
Max. total cable length: 20 meters

Accessory

Power supply cable M8, straight, female, 4-pin – M12, straight, male, 4-pin:

- **CDM8M12**: length. 1 m.



LEMAX IO

Mini Vacuum Pumps with Communication IO-Link

Option, Choice of Layout



AIR Saving Control

IO-Link



Exhaust manifold: option E

The LEMAX IO mini vacuum pumps can be equipped with the "exhaust manifold" option, which provides a G1/8"-F connection to the exhaust in order to add a silencer, transfer the exhaust outside the work area or to avoid air discharge near the workpiece (LEMAXIO___E version).

This option must be specified at time of ordering as it cannot be added later.

Note: The design of the exhaust manifold and vacuum pumps do not guarantee the complete sealing of the exhaust and therefore cannot be used in a "clean room" environment.

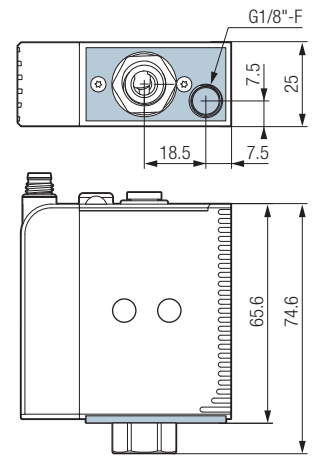

Stand-alone or Island Modules?

Stand-alone modules are suitable for the most common applications: one module controls one or more suction cups which all operate according to the same sequence.

When several suction cups are operating according to different sequences, multiple modules are required, which can be:

- several autonomous modules;
- a group of these modules with an internal common pressure unit.

The illustrations opposite guide the selection:

- stand-alone modules are coupled with integrated pressure regulators
- in an island, the integrated regulator is removed: to maintain the advantage of economical and silent operation, it is recommended to reduce the island's common pressure supply pressure to 4 bar.

Network pressure:
4.5 to 7 bar

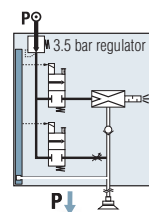

stand-alone module

common pressure unit (4 bar)

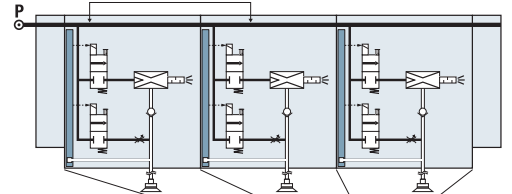

P optimal = 4 bar
(operation at 4-7 bar)



island of 3 modules
supplying suction cups
according to different
sequences

Assembling and Connecting an Island

island of 4 modules

set of ends for the island.

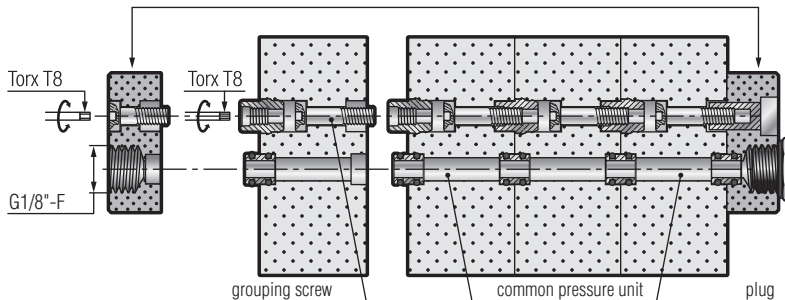

island of 3 modules



Maximum number of modules in an island:

- Ø 1.4 mm nozzle → 5 modules
- Ø 1.2 mm nozzle → 7 modules
- Ø 1 mm nozzle → 9 modules

LEMAX IO

Mini Vacuum Pumps with Communication IO-Link Configuring a Vacuum Pump



AIR Saving Control

IO-Link



Part numbers for an island assembly or components in an island

Part numbers for stand-alone units

LEMAXIO 90 X 14 S C14 - B2

VACUUM LEVEL

maximum 85% vacuum optimum for airtight objects

90

NOZZLE DIAMETER

Ø 1.4 mm nozzle

14

Ø 1.2 mm nozzle

12

Ø 1 mm nozzle

10

EXHAUST

Open (integrated silencer)

-

Exhaust manifold (G1/8"-F)

E

ISLAND ASSEMBLIES

B2

LEMAXIO90X...**B2**
Island assembly with 2 identical modules.



B3

LEMAXIO90X...**B3**
Island assembly with 3 identical modules.



B4

...

If the planned island contains different module types, it must be ordered as separate components in order to then be assembled on site according to the arrangement suitable to the application.

COMPONENTS FOR THE ISLAND TO BE ASSEMBLED

B

LEMAXIO...**B**
Module that can be grouped (complete with integrated grouping screw).



Set of ends for a complete island, with grouping screw and common pressure unit plug.



PART NO.: LEMSETA

COMPOSITION OF THE MODULE

Vacuum pump controlled by a Normally Closed (NC) solenoid valve

S

LEMAXIO90X...**S**...

- In the event of an electrical shut-off, vacuum is no longer generated.
- Optional configured blow-off:
 - by specific signal,
 - automatic, timed 0 to 9.9 sec. (→ a single control signal vacuum and blow-off).

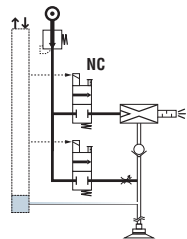

Vacuum pump controlled by a Normally Open (NO) solenoid valve

V

LEMAXIO90X...**V**...

- In the event of an electrical shut-off, the vacuum continues to be generated: gripped object held → positive security.
- Blow-off controlled by a specific signal.

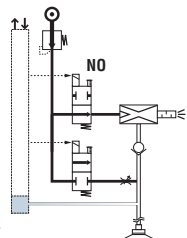

REFERENCE EXAMPLE COMPOSED OF A STAND-ALONE MODULE:

LEMAXIO90X14SC14

LEMAX IO, mini vacuum pump, 85% max. vacuum, 1.4 mm nozzle, controlled by a NC (Normally Closed) solenoid valve.

EXAMPLE COMPOSITE PART NUMBER FOR AN ISLAND ASSEMBLY:

LEMAXIO90X14SC14B3

LEMAX IO group assembly, containing 3 x 85% max. vacuum modules, Ø 1.4 mm nozzle, controlled by NC (Normally Closed) solenoid valve.

ORDER EXAMPLE FOR AN ISLAND TO BE ASSEMBLED:

LEMAXIO90X14VC14B

LEMAXIO90X12SC14B

LEMAXIO90X10VC14B

LEMSETA

3 LEMAX IO modules for an island, of different types.

Set of ends for island.

LEM MAX IO

Mini Vacuum Pumps with Communication IO-Link Dimensions, Mounting Options



AIR Saving Control

IO-Link



1- Stand-alone Modules

Mounting from side

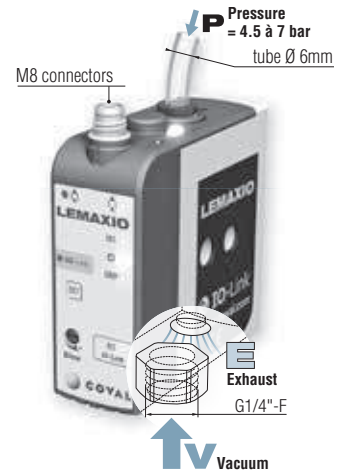
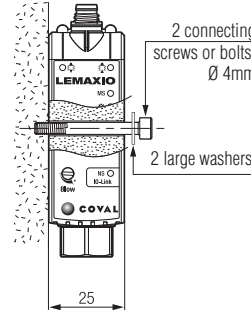
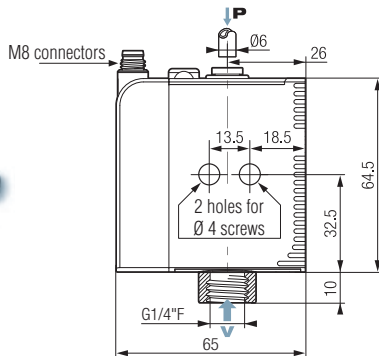

Mounting from front

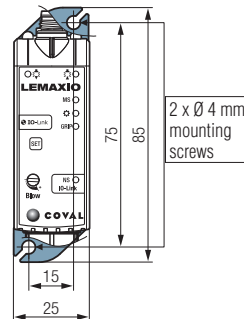
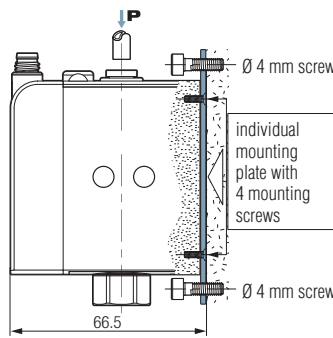

To mount from front, in addition to the module, a mounting kit must be ordered:

Kit for mounting from front:
1 plate + 4 screws

Part No.: LEMFIXA

Mounting on DIN rail

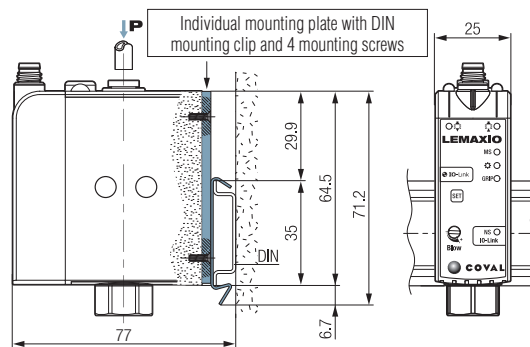

For static mounting (for example, in a cabinet), a module can be clipped onto a DIN rail. For this purpose, the module must first be equipped with an individual plate for mounting onto a DIN rail

DIN rail mounting kit:
1 plate/clip + 4 screws

Part No.: LEMFIXB

2- Islands

Mounting from front

Mounting on DIN rail

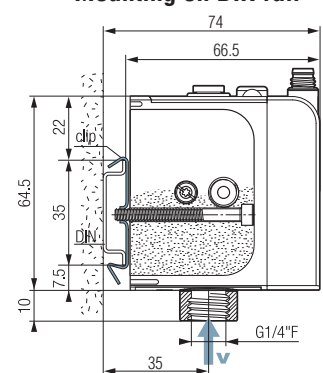
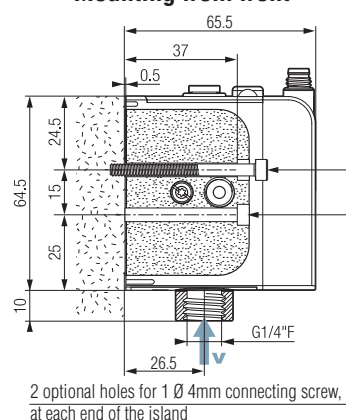
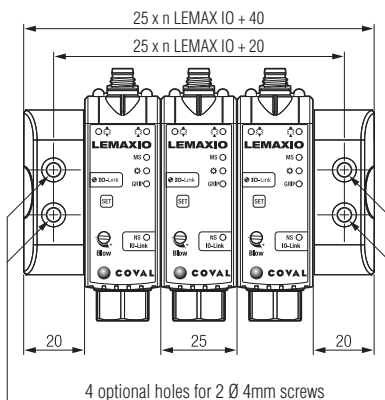

2 optional holes for 1 Ø 4mm connecting screw, at each end of the island

DIN rail mounting kit:
2 clips + 2 screws

Part No.: LEMFIXC

LEMAX IO

Mini Vacuum Pumps with Communication IO-Link

Characteristics



AIR Saving Control

IO-Link



Overall Characteristics

- Supply: non-lubricated air filtered to 5 microns according to standard ISO 8573-1:2010 [4:5:4].
- Operating pressure: 4.5 to 7 bar.
- Mini dynamic pressure:
 - stand-alone version: P = 4.5 bar.
 - island version: P = 4 bar.
- Blow-off: adjustable flow:
 - stand-alone version: P = 3.5 bar.
 - island version: P network
- Maximum vacuum: 85%
- Suction rate: 29 to 70 NI/min.
- Air consumption: 44 to 90 NI/min during "ASC" off operation.
- Integrated clog-free silencer.
- Noise level: approximately 68 dBA "ASC" off. 0 dBA with "ASC".
- Electrical protection level: IP 65.
- Max. operating frequency: 4 Hz.
- Endurance: 30 million cycles.
- Weight: 130 g.
- Operating temperature: from 0 to 50°C (32 to 122°F).
- Materials: PA 6-6 15%FV, brass, aluminum, NBR.
- 4-pins M8 male connector.

Analysis of the vacuum regulation system (ASC)

- Constant monitoring of leakage rate: abandon or automatic return to "ASC" operation.

Integrated electronics

- 24 V DC supply (regulated $\pm 10\%$).
- Electric consumption < 100 mA, of which 30 mA (0.7W) per vacuum and blow-off pilot.
- Measurement range: 0 to 99% vacuum.
- Measurement accuracy: $\pm 1.5\%$ of range, temperature compensated.
- Inputs/outputs protected against wiring errors or reversed polarity.
- IO-Link Operation.

Diagnosis

- Instantaneous vacuum level (0 to 99%).
- Gripped product, loss of product, regulation in process, regulation default information.
- Cycle counters (vacuum, blow-off, gripped piece, ASC, etc.).
- Supply voltage.
- Product reference and serial number.
- Firmware version.

Accessory

Protection for standalone mini-vacuum pumps LEMAXIO__SC14
(with one M8 connector), Part No.: **80004409**

The COVER is made of silicone and serves as a protective sleeve for vacuum pumps, protecting them against splashing water, in particular during cleaning cycles.

- High level of protection against splashing water
- Easy to mount and clean



Displays

- Control status indicators:
 - "vacuum": green LED
 - "blowoff": orange LED
- "Part gripped" indicator: green LED
- Configurable indicator: blue LED
- "Module Status" indicator: green/red LED
- "IO-Link Network Status" indicator: green/red LED

Settings

- Piece gripping (L1) and regulation (L2) thresholds.
If the application so requires, specific adjustment of thresholds and hysteresis different to original factory settings (L1=65% h1=10%, L2=75%, h2=10%).
- Automatic timed blow-off (0 to 10 seconds) only on LEMAXIO90X__S__
- Activation/deactivation of ASC regulation system.
- Activation/deactivation of the (DIAG ECO) leakage level monitoring system.
- Adjustable blue LED functioning mode
- Valve functioning mode in the event of loss of communication.
- Back to "factory" settings.

IO-Link

- Revision: 1.1
- Transmission rate: COM2 / 38.4 kbit/s
- Min. cycle time: 3.6 ms
- SIO mode: No.
- Process Data Input (PDI): 4 bytes.
- Process Data Output (PDO): 1 byte.
- IO device description file (IODD) available for download.
- Max. total cable length: 20 meters.

8

LEMAX IO

LEMCOM

1st Mini Vacuum Pump on Industrial Fieldbus General Points

In a world where everything is connected, COVAL is innovating once more by unveiling the LEMCOM series: the first vacuum pump on fieldbus.

The LEMCOM establishes a verified remote communication between the operator and the vacuum pump, with two possible fieldbus choices, EtherNet/IP and PROFINET. This allows the operator to receive real-time information and more importantly respond at all times to configure, diagnose and maintain the operation.

Compact Integration: The COVAL Technique

The illustrations demonstrate the COVAL advantage: all necessary functions are integrated into a complete and self-governing mini-module.

INTEGRATED FUNCTIONS:

- ❶ Pressure regulator 3.5 bar
- ❷ "Vacuum" solenoid valve
- ❸ 3.5 bar optimized venturi
- ❹ Optimized silencer
- ❺ Vacuum non-return valve
- ❻ Vacuum sensor
- ❼ Integrated electronics: management of "vacuum" functions and communication
- ❽ "Blow-off" solenoid valve
- ❾ Blow-off flow regulator

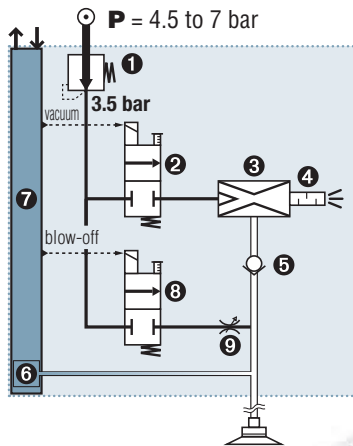

PROFI
NET
EtherNet/IP™



PROFI
NET
EtherNet/IP™

Industry-specific applications

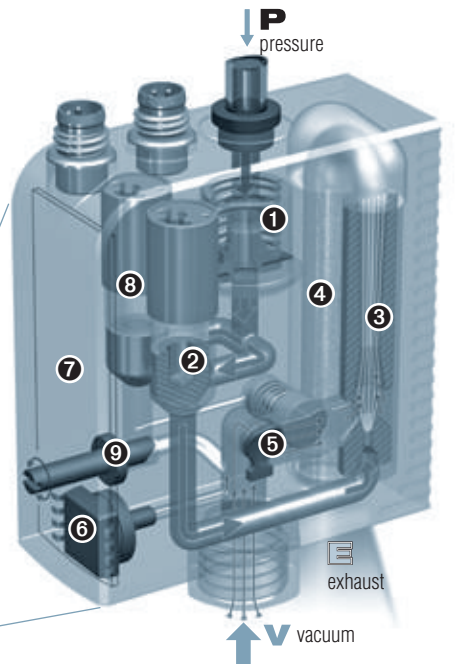
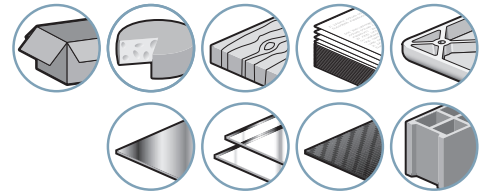

Schematic representation

8

LEMCOM

Easy Integration with Existing Industrial Network

LEMCOM is the first vacuum pump which seamlessly integrates with the field network without the use of gateways or other specific interfaces.

The LEMCOM "master" modules enable the continuity of a fieldbus through their two integrated communication ports. Tested and certified by ODVA (EtherNet/IP) and by PI (PROFINET), LEMCOM is connected very easily to the PLC (EDS file, RSLogix 5000 Add-On Instructions, GSDML file).

Based on a "master/secondary" structure where the "master" is a fully-integrated pump, the LEMCOM design enables the supply and control of 1 to 16 vacuum pumps while requiring only 2 connecting cables.

Advantages

- **Easy implementation:** Plug & Play, custom configuration for every type of application.
- **Maximum automatic energy savings:**
 - ASR: 40% savings for porous products.
 - ASC: 90% savings for airtight products.
- **Compactness:** LEMCOM vacuum pumps are the most compact on the market.
- **Short response times:** Installed in close proximity to vacuum cups.

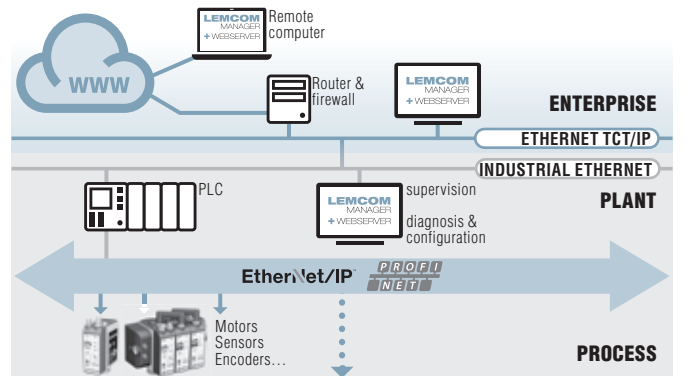

- **Dust resistant:** Non-clogging through-type silencer.
 - **Safety:** Product gripping is maintained even during power failure.
 - **Supported buses:** EtherNet/IP and PROFINET.
 - **Wiring simplified:** 2 cables are capable of managing 1 to 16 modules.
 - **Settings and diagnosis via remote monitoring.**
 - **Nearly unlimited arrangements** (stand-alone modules, island assemblies or remote modules).
- An essential innovation for intelligent vacuum gripping.



PROFINET EtherNet/IP



2 Vacuum Levels to Match Precise Application Needs

VERSION 60 (Max. 60% vacuum)

To enable a high rate of vacuum flow and compensate for leakage when gripping porous materials.



Suction flow rate (NI/min):

max. vacuum Nozzle Ø	60%
1.0 mm	38
1.2 mm	72
1.4 mm	92

VERSION 90 (Max. 85% vacuum)

To enable a high vacuum level and thus increase the holding force for gripping airtight materials.



Suction flow rate (NI/min):

max. vacuum Nozzle Ø	85%
1.0 mm	29
1.2 mm	45
1.4 mm	70

	Porous Materials, Rough Surfaces				Airtight & Semi-Porous Materials				
	Cardboard	Food	Wood	Paper	Plastic	Metal	Glass	Composites	Concrete/Stone
LEMCOM 60	●	●	●	●	●	●	●	●	●
LEMCOM 90					■	■	■	■	■

● Air Saving Regulator → 40% of energy savings on average.

■ Air Saving Control → 90% of energy savings on average.

Integrated Energy-saving Technologies

AIR Saving Regulator

40% energy savings (on average, see below).

Combined "venturi regulator" ASR: pressure regulator ① feeds venturi ③ with 3.5 bar, the optimized pressure for operation.

→ No more unnecessary consumption of compressed air.

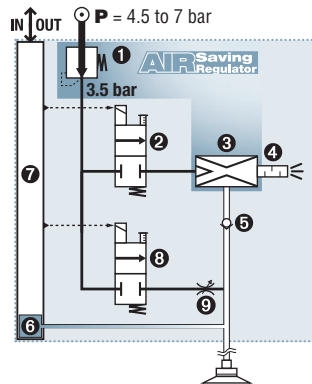

AIR Saving Control

90% energy savings (on average).

Combination of non-return valve ⑤ and advanced electronics ⑦ ensures ASC's automatic performance.

→ Once vacuum is established, the pump no longer consumes air to hold the product.

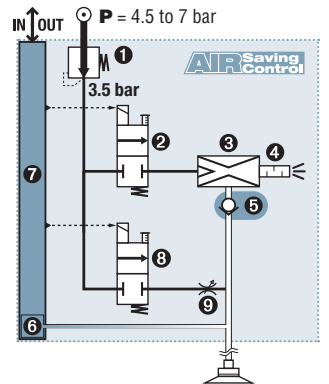

AIR Saving Regulator (ASR): Air Saving Regulator

LEMCOM series vacuum pumps, which integrate an ASR "venturi regulator" combination, maintain ideals that COVAL values greatly: reducing both compressed air consumption and noise generation.

Regardless of pressure supplied by the compressed air network, the integrated regulator feeds the venturi at 3.5 bar pressure, optimal for its operation.

→ No more unnecessary energy consumption.

→ No external regulator required, thus eliminating the risk of improper adjustment.

Compared to pressures found in most compressed air networks (5-7 bar), the graph opposite demonstrates an achieved economy of 40% on average.

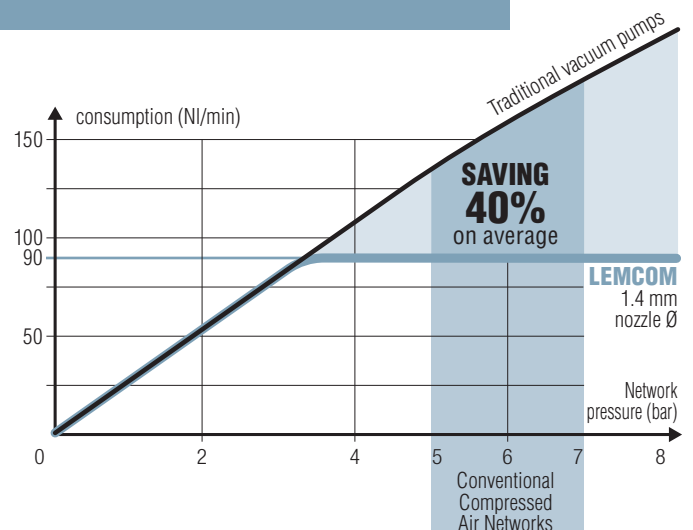



PROFI
NET EtherNet/IP



AIR Saving Control "Air Saving Control" Cycle

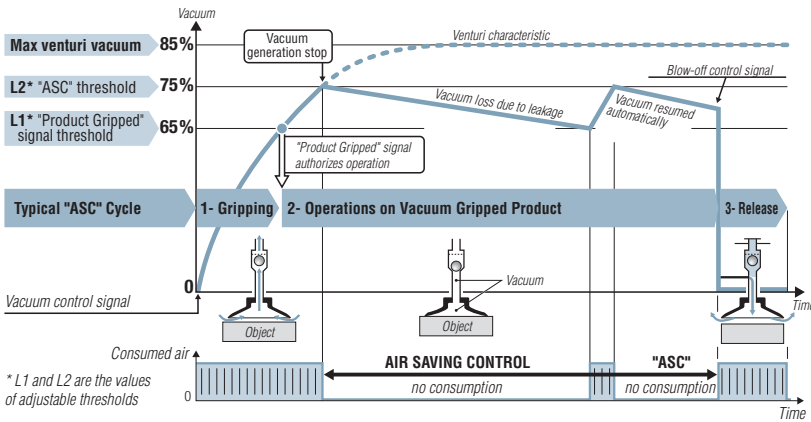

As illustrated above, the LEMCOM module automatically executes the "ASC", cycle, thus saving the maximum amount of energy, based on the following 3 phases.

1- Gripping the object

The "vacuum" solenoid starts the cycle by supplying the venturi which generates the vacuum to quickly pick up the object with the suction cup → short-term consumption.

2- Operations on the object held by vacuum

The vacuum level is constantly monitored by the vacuum switch. When it reaches the L1 threshold (65%), the "gripped object" signal is generated, which allows the planned operations (transfer, machining, etc.). When the vacuum reaches threshold L2 (75%), the supply to the venturi via the solenoid valve is cut off → consumption is halted. The object remains held by the retained vacuum thanks to the closed valve. Micro-leaks will generally cause the vacuum level to fall slowly. Each time it falls below 65%, vacuum generation is briefly resumed until it reaches threshold L2 (75%).

3- Releasing the object

At the end of operations, blow-off is ordered. The "blow-off" solenoid valve generates a stream of air which closes the isolation valve, blows on the object to release it quickly.

Smart Adaptation

The illustration above shows the adaptation capability of the LEMCOM module. "ASC" operation is automatic for any object that is airtight or generally nonporous (cycle 1). If a leak occurs (cycle 2), due to a rough object or suction cup wear:

1/ the module automatically detects the anomaly, 2/ ends the cycle without "ASC" in order to continue production and 3/ reports the event for possible maintenance. Production continues and once everything is returned to normal (cycle 3), "ASC" operation is automatically resumed.

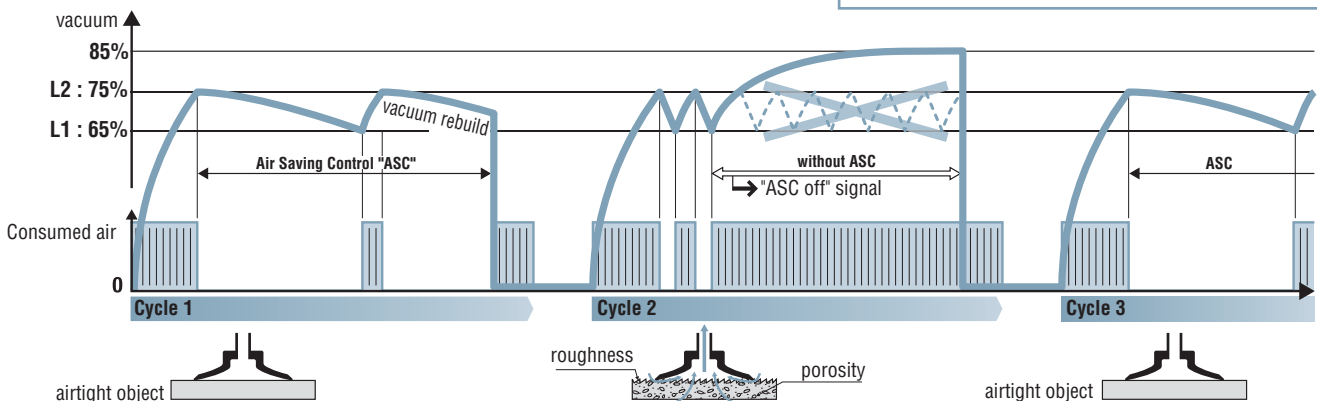

1- Gripping + Transfer (1.4 mm nozzle Ø, emptying 0.2 l)

Phase	Duration	Air consumption		Energy savings achieved
		without "ASC"	with "ASC"	
Gripping	0.28 s	0.4 NI	0.4 NI	75 %
Transfer	1.20 s	1.8 NI	0	
Release	0.14 s	0.2 NI	0.2 NI	
		2.4 NI	0.6 NI	

2- Clamping + Operations (1.4 mm nozzle Ø, emptying 0.4 l)

Phase	Duration	Air consumption		Energy savings achieved
		without "ASC"	with "ASC"	
Clamping	0.55 s	0.8 NI	0.8 NI	99 %
Operations	60 s	90 NI	0	
Release	0.14 s	0.2 NI	0.2 NI	
		91 NI	1.0 NI	

Resulting Savings

Energy savings from "ASC" are significant, as the two examples opposite show:

- 75% savings for transferring an object after gripping.
- 99% savings for holding an object during a 1 minute operation.

The product often pays for itself in just a few months.

"ASC": AN ADVANTAGE WITHOUT LIMITATIONS

Saving energy has become essential. With LEMCOM, thanks to ASC, energy is saved automatically without interfering with established practices:

1- No specific adjustment

The default setting (L1 = 65%, L2 = 75%) is suitable for most applications.

2- Production regardless of conditions

Performance is guaranteed. When necessary, without "ASC", if the leakage level is too high.

3- Guided maintenance

Clear display of the need for maintenance in order to return to autoregulated "ASC" operation.

With LEMCOM, all settings are remotely configurable, and diagnosis is made easier.



PROFI
NET EtherNet/IP

Individual or Island Modules?

Stand-alone modules are suitable for the most common applications: one module controls one or more suction cups, all of which operate according to the same sequence. When several suction cups are operating according to different sequences, multiple modules are required, which can be:

- several autonomous modules, OR
- a group of these modules with an internally shared pressure supply

The illustrations shown here guide the selection:

- autonomous modules are coupled with integrated pressure regulators (ASR)
- in a group, the integrated regulator is eliminated: to maintain the advantage of economical and silent operation, it is recommended to reduce the group's common pressure supply to 4 bar.

The maximum number of modules in an island depends on the power of the modules that must be active simultaneously:

- 5 modules maximum for nozzle 1.4 mm ID.
- 7 modules maximum for nozzle 1.2 mm ID.
- 9 modules maximum for nozzle 1 mm ID.

Network: 4.5 to 7 bar

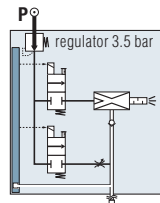

stand-alone module

Optimal pressure: 4 bar

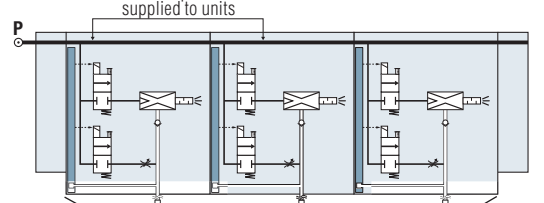

P optimal = 4 bar
(operation at 4-7 bar)

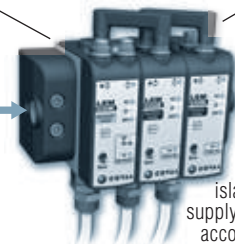

island of 3 modules supplying suction cups according to different sequences or operations

Vacuum Control by NC or NO Solenoid Valve

Vacuum control by NC (Normally Closed) solenoid valve is the most common: in the event of an electrical shut-off, vacuum is no longer generated. On the other hand, with a NO (Normally Open) solenoid valve, vacuum continues to be generated in the event of an electrical shut-off, providing positive object-gripped security. The diagrams opposite show that both versions are controlled by the same "vacuum" signal v : The opposite \bar{v} required for control of the NO solenoid valve is automatically obtained internally by the control electronics.

■ NC solenoid valve

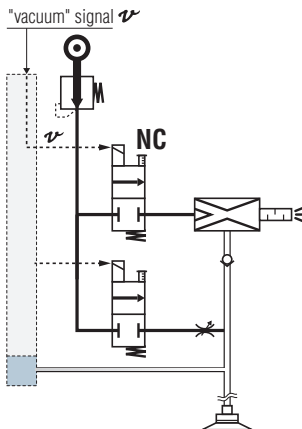

■ NO solenoid valve

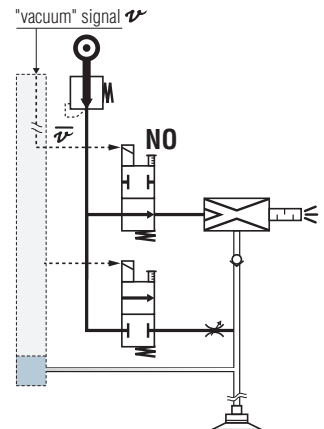

Communications Panel

LEMCOM master
PROFI EtherNet/IP

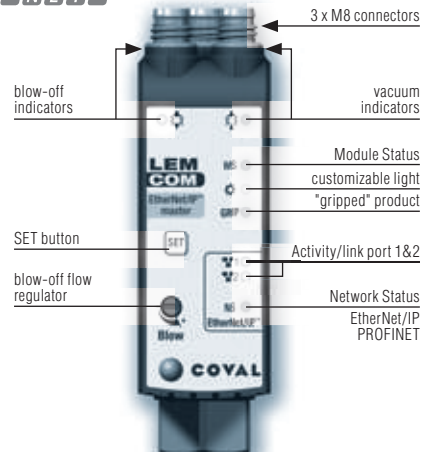

LEMCOM secondary module

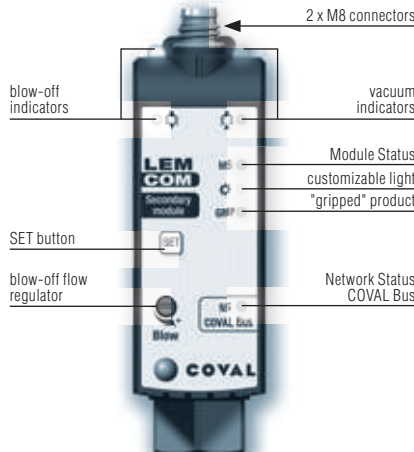

LEMCOM

1st Mini Vacuum Pump on Industrial Fieldbus Simplified Communication along the Entire Line



PROFINET EtherNet/IP™

Multitude of Innovations

- Maximum intelligence / minimal bulk.
- One "master" module controls up to 15 secondary modules.
- Master module is a fully-integrated pump.
- Remote configuration, monitoring and diagnostics.
- Dedicated Coval bus between master and secondary modules.
- Simplified wiring and installation.
- Standard secondary modules (regardless of the type of bus).
- Additional communications port.
- Supported buses: EtherNet/IP™ / PROFINET / CANopen.
- IP 65 / M8 standard connectors.

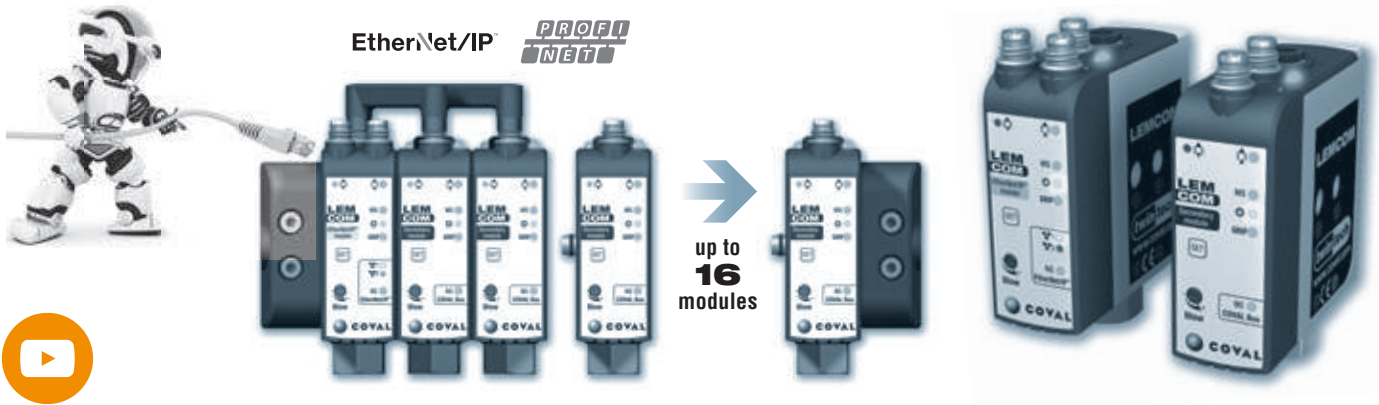

A Simple Product to Utilize

LEMCOM master

- On-board 2-Port Ethernet Switch.
- On-board web server.
- Dedicated configuration software.
- M8/RJ45 standard connectors.

EtherNet/IP
PROFINET



Dedicated application **LEMCOM** MANAGER

Vacuum management made easy

Specially developed with vacuum handling applications in mind, LEMCOM Manager is a PC software package which allows you, in just a few clicks, to remotely set up and configure LEMCOM vacuum generators as well as run diagnostics.

Packed with numerous functions such as the import/export of parameters, vacuum cycle analysis, alarm and operation cycle monitoring, configuration help or even embedded firmware updating.

The application allows all LEMCOM mini pumps to be controlled remotely over the network either by the end user or by COVAL's technical support teams.



LEMCOM secondary module

- Universal secondary module, whatever the type of bus used.



Settings, Diagnosis, and Process Data



CONFIGURABLE SETTINGS

- "Product Gripped" and vacuum regulation (ASC) thresholds.
- Automatic blow-off.
- State of valves in the event of loss of communication.
- Client LED status.
- Network parameters.
- Firmware updates...



DIAGNOSTIC

- Cycle counters, vacuum and blow-off control, gripped pieces, lost pieces, ASC...
- Power supply voltage.
- Firmware version.
- Product reference.
- Vacuum cycle acquisition...



INPUT DATA

- Vacuum and blow-off control.



OUTPUT DATA

- Instant vacuum level (0 to 100%).
- "Gripped Product" signal (ON/OFF).
- Regulation system status.
- Alarms (power supply voltage, temperature, preventive maintenance).

8 LEMCOM



PROFINET EtherNet/IP



A Setting for Every Application

The LEMCOM is based on an innovative, efficient product structure:

- The "master" module manages communication on the fieldbus, assures management of the "secondary" modules and is a fully-integrated vacuum pump. Its 2 communication ports enable a continuous fieldbus.
- The "secondary" modules are interconnected with the "master" module via the COVAL bus.

Contact between the "master" module and the "secondary" modules is confirmed by an M8 connecting bridge for island configurations or by a M8/M8 standard cable for configurations based on remote modules.

Advantages:

This product structure guarantees flexibility in selection, enabling use of LEMCOMs in stand-alone, island or mixed configurations. As a result, vacuum generators may be placed in close proximity to the application, guaranteeing a reduction:

- in gripping time
- in cycle time
- in energy consumption.

Because setup and diagnosis of the LEMCOM is carried out remotely, it is not necessary to install them in easily accessible zones.

STAND-ALONE CONFIGURATION

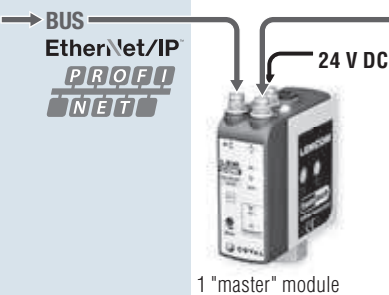

ISLAND CONFIGURATION

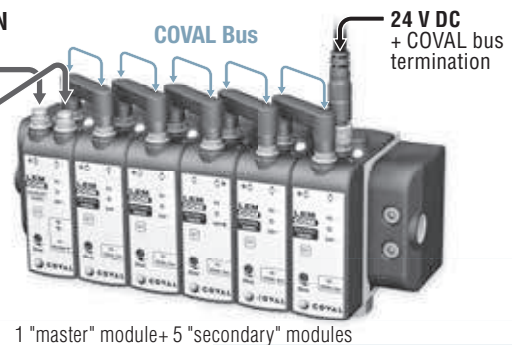

CUSTOMIZED CONFIGURATIONS

- BUS → LEMCOM
→ Motors
→ Encoders
→ Actuators...

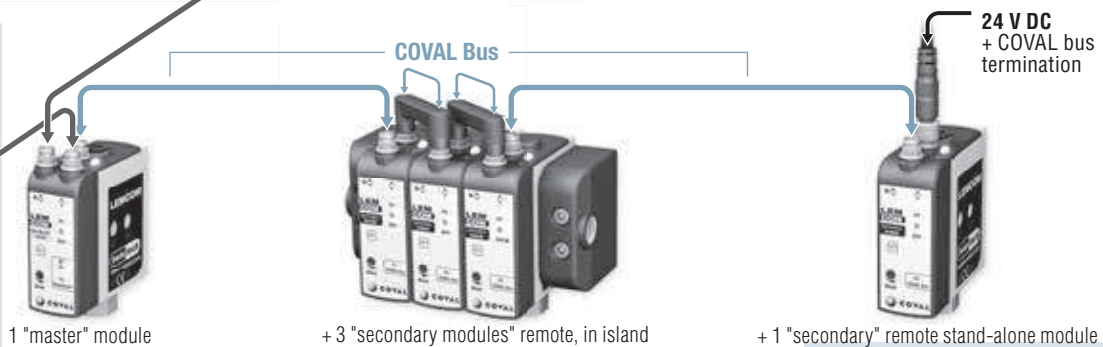

Full Remote Access

LECOM parameters can easily be updated remotely and in several ways. Configuration is possible using LEMCOM Manager PC software, the embedded web server (EtherNet/IP and PROFINET) or by sending vacuum parameters directly from the PLC during use or on initialization.

This flexibility enables the LEMCOM user to adapt to all types of applications without direct intervention on the vacuum generator.

EtherNet/IP PROFINET

- Embedded web server.
- Implicit (I/O) and explicit messaging (setting) (EtherNet/IP).
- Synchronous (I/O) and asynchronous data (configuration) (PROFINET)

LECOM MANAGER

- Dedicated universal application: LEMCOM Manager.

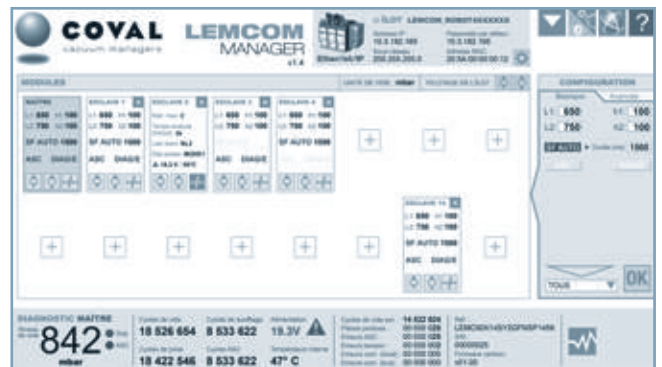



PROFINET EtherNet/IP



Venturi Specifications

1- Maximum Vacuum Level

Dependent upon the mixer profile:

- 85% of maximum vacuum is optimal for gripping airtight products.
- 60% of maximum vacuum is optimal for gripping porous products.

2- Nozzle Diameter

Reflects the generated vacuum flow rate, as well as energy consumption. Hence, it must be selected to meet precise requirements without wasting energy.

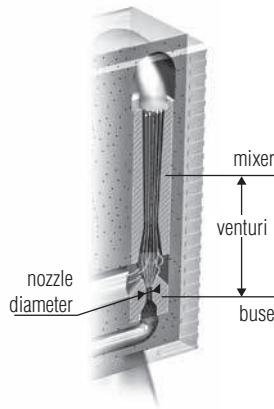

Suction Flow Rate / Vacuum Curves

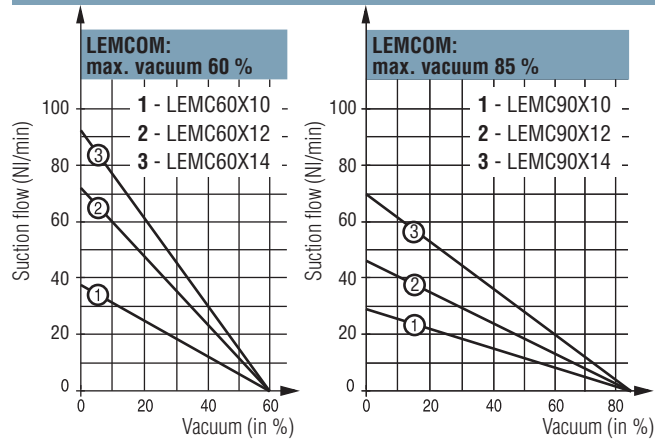

Handling of Porous Products: (cardboard, untreated wood, pastries, etc.) → LEMCOM 60% max. vacuum

When porosity and/or surface leaks are expected during gripping, a vacuum level between 35% and 55% is the best economical compromise generated by a maximum **venturi vacuum level of 60%**. To determine the most effective nozzle diameter, use the table at right and measure the leakage flow rate of the material.

Evacuation time (in seconds) of 1 liter volume	vacuum reached			Consumed Air (NI/min)	Vacuum flow (NI/min)
	35%	45%	55%		
Nozzle Ø					
1.0 mm	0.83	1.31	2.35	44	38
1.2 mm	0.52	0.83	1.49	65	72
1.4 mm	0.34	0.54	0.97	90	92

Handling of Airtight Products: (glass, plastic, coated wood, sheet metal, etc.) → LEMCOM 85% max. vacuum

Gripping done without major leaks will benefit from a high level of vacuum: Between 55% and 75% generated by a maximum **venturi vacuum level of 85%**.

Depending on the volume to be evacuated and the time available for product gripping, use the table below to select the most effective nozzle diameter and vacuum flow rate.

AIR Saving Control On airtight products, "ASC" enables you to considerably reduce compressed air consumption. The table below shows:

- A larger nozzle provides a faster grip without consuming more, when using "ASC".
- A smaller nozzle only consumes less when the operation is continued without "ASC".

Working without "ASC":

Evacuation time (in seconds) of 1 liter volume	vacuum reached			Consumed Air (NI/min)	Vacuum flow (NI/min)
	55%	65%	75%		
Nozzle Ø					
1.0 mm	1.76	2.38	3.33	44	29
1.2 mm	1.13	1.53	2.15	65	45
1.4 mm	0.73	0.99	1.38	90	70

When using "ASC" (evacuation of 1 liter volume):

Ø buse	gripping time (65% vacuum) (s)	Time up to 75% vacuum (s)	Consumed Air (NI)
1.0 mm	2.38	3.33	2.2
1.2 mm	1.53	2.15	2.2
1.4 mm	0.99	1.38	2.2

Exhaust manifold: option E

The LEMCOM mini vacuum pumps can be equipped with the "exhaust manifold" option, which provides a G1/8"-F connection to the exhaust in order to add a silencer, transfer the exhaust outside the work area or to avoid air discharge near the workpiece. (LEMC__E Version).

This option must be specified at time of ordering as it cannot be added later.

Note: The design of the exhaust manifold and vacuum pumps do not guarantee the complete sealing of the exhaust and therefore cannot be used in a "clean room" environment.

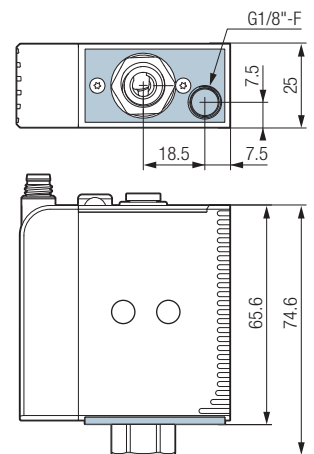



PROFIBUS EtherNet/IP™



LEMCOM 90 X 12 S Y2 G - B2

VACUUM LEVEL	
60 % max. vacuum is optimal for porous materials	60
85 % max. vacuum is optimal for airtight products	90

NOZZLE DIAMETER	
1 mm Ø nozzle	10
1.2 mm Ø nozzle	12
1.4 mm Ø nozzle	14

MODULE COMPOSITION

NC Vacuum pump with blow-off

LEMCOM_X_S_G

NC vacuum control valve:

→ in case of electrical cut-off, vacuum generation stops.

Blow-off configured on site at choice:

- Blow-off controlled by specific signal;
- Automatically delayed blow-off time from 0 to 10 s.

Adjustable blow-off flow rate.

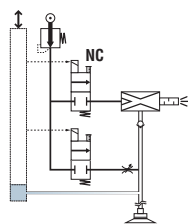

S

NO Vacuum pump with blow-off

LEMCOM_X_V_G

NO vacuum control valve:

→ In case of electrical cut-off, vacuum continues to be generated.

Blow-off configured on site, at choice:

- Blow-off controlled by specific signal;
- Automatically delayed blow-off time from 0 to 10 s.

Adjustable blow-off flow rate.

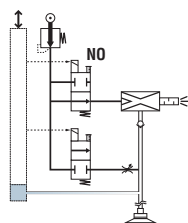

V

PROTOCOL

Q2

PROFIBUS master
LEMCOM_X_Q2G



- On-board 2-Port Ethernet Switch.
- On-board web server.
- Dedicated configuration software.
- M8/RJ45 standard connectors.
- GSDML file.

Y2

EtherNet/IP™ master
LEMCOM_X_Y2G



- On-board 2-Port Ethernet Switch.
- On-board web server.
- Dedicated configuration software.
- M8/RJ45 standard connectors.
- RSLogix 5000 AOI + EDS file.

Z2

secondary module
LEMCOM_X_Z2G



- Universal secondary module, can be used with any fieldbus.
- If necessary, M8/M8 "COVAL Bus" 120 Ω termination, available in accessories.

EXHAUST

Open (integrated silencer) **-**

Exhaust manifold (G1/8"-F) **E**

CONFIGURATION

1 stand-alone module

Island assemblies

B2

LEMCOM_X_GB2



Island assembly with 2 modules, with connecting bridges for internal "COVAL Bus" and M8/M8 120 Ω termination:

- The first module is of the type selected in "PROTOCOL".
- The following one is a secondary module.

B3

LEMCOM_X_GB3



Island assembly with 3 modules, with connecting bridges for internal "COVAL Bus" and M8/M8 120 Ω termination:

- The first module is of the type selected in "PROTOCOL".
- The following two are secondary modules.

B4

...

NB: LEMCOM_X_Z2GB. "Secondary" island modules are delivered without the M8/M8 "COVAL Bus" 120 Ω termination - order separately.

Components for island assembly

B

LEMCOM_X_GB



Island module, complete with integrated assembly screw.



Island endplates set complete with assembly screw and plug for common pressure inlet.

Part No.: LEMSETA



Connecting bridge for internal "COVAL Bus".

Part No.: 80001231

NB: If necessary, M8/M8 "COVAL Bus" 120 Ω termination is available in accessories

OPTION: Version without non-return valve available on request.

EXAMPLES OF COMPLETE PART NUMBER:

LEMCOM90X14SY2G LEMCOM vacuum pump, 85% maximum vacuum, 1.4 mm Ø nozzle, controlled by a NC (Normally Closed) solenoid valve, stand-alone EtherNet/IP™ "master" module.

LEMCOM90X10SY2GB3 Island assembly of 3 LEMCOM vacuum pumps, 85% maximum vacuum, 1 mm nozzle Ø, controlled by a NC (Normally Closed) solenoid valve, EtherNet/IP™ "master" module, 2 secondary modules, with connecting bridges and the M8/M8 "COVAL Bus" 120 Ω termination.

LEMCOM

1st Mini Vacuum Pump on Industrial Fieldbus

Dimensions, Mounting Options



PROFINET

EtherNet/IP



1- Stand-alone Modules

Mounting from side

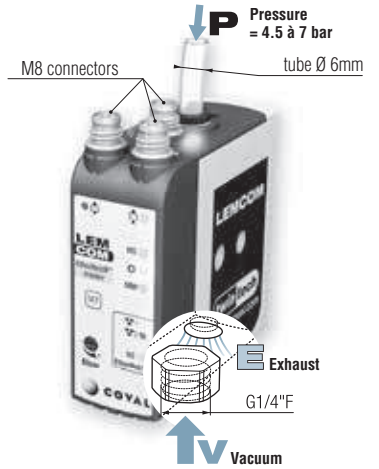
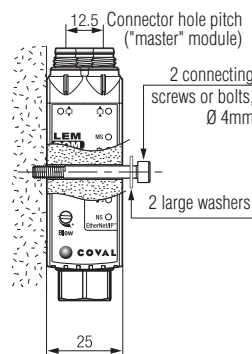
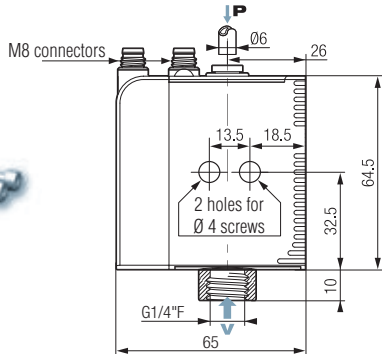

Mounting from front

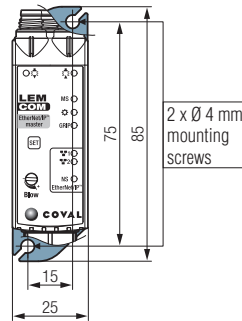
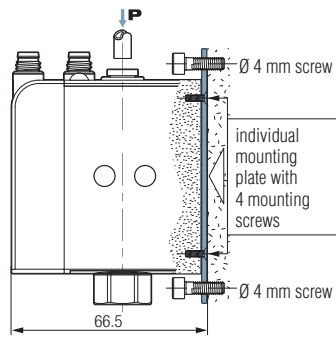

To mount from front, in addition to the module, a mounting kit must be ordered:

Kit for mounting from front:
1 plate + 4 screws

Part No.: LEMFIXA

Mounting on DIN rail

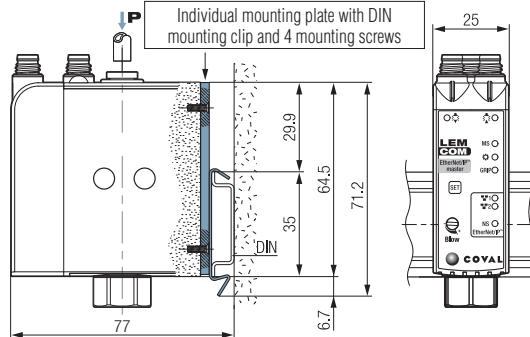

For static mounting (for example, in a cabinet), a module can be clipped onto a DIN rail. For this purpose, the module must first be equipped with an individual plate for mounting onto a DIN rail

DIN rail mounting kit:
1 plate/clip + 4 screws

Part No.: LEMFIXB

2- Islands

Mounting from front

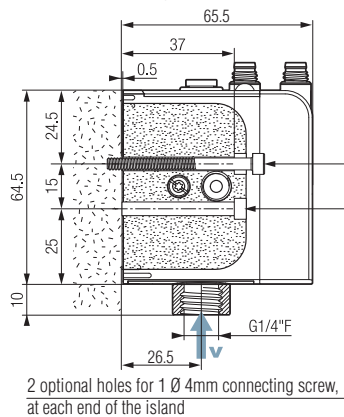
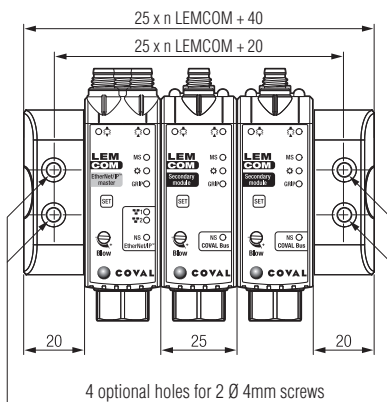

Mounting on DIN rail

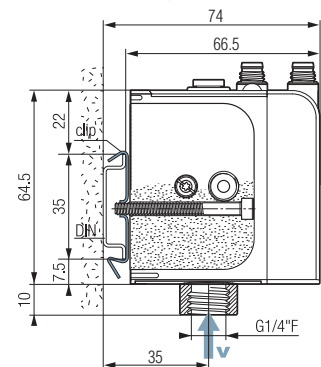

DIN rail mounting kit:
2 clips + 2 screws

Part No.: LEMFIXC

LEMCOM 8



PROFI
NET EtherNet/IP

Electrical Connections

LEMCOM master
EtherNet/IP **PROFI**
NET

LEMCOM
secondary module

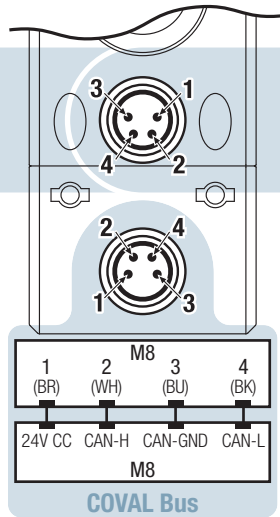
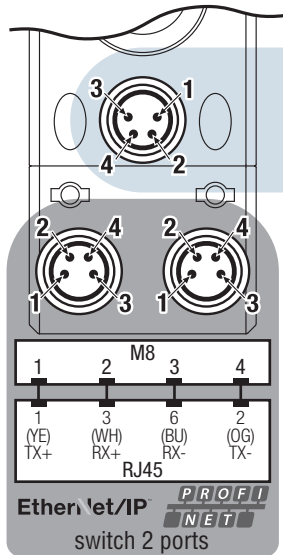

→ "COVAL bus"

→ power supply

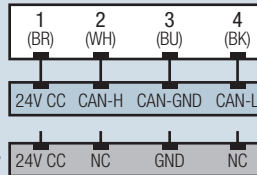

M8/M8 "COVAL BUS" 120 Ω TERMINATION

Male M8/Female M8 cable integrating a 120 Ω termination resistor. The termination must be integrated on the last "secondary" module of the COVAL Bus, between the final M8 connector of the product and the 24V DC electric supply.



ACCESSORIES

Cat 5 shielded Ethernet cable: M8, straight, female, 4-pin – RJ45, straight, male, 8-pin – suitable for drag chain use

- **CDM8RJ45L2**: length 2 m.
- **CDM8RJ45L5**: length 5 m.
- **CDM8RJ45L10**: length 10 m.

Other lengths on request.

Cat 5 shielded Ethernet cable: M8, straight, female, 4-pin, on both ends – suitable for drag chain use

- **80003053**: length 1 m.

M8/M8 "COVAL bus" cable: M8, straight, female, 4-pin – M8, straight, female, 4-pin

- **CDM8FFL05**: length 0.5 m.
- **CDM8FFL1**: length 1 m.
- **CDM8FFL2**: length 2 m.
- **CDM8FFL4**: length 4 m.

Other lengths on request.

Power supply cable: M8, straight, female, 4-pin – open end

- **CDM8**: length 2 m.
- **CDM8N**: length 0.5 m.

120 Ω "COVAL bus" termination: M8, straight, female, 4-pin – M8, plug, male, 4-pin

- **80002303**: length 0.2 m.

The COVAL bus is based on a CAN architecture and requires the addition of a bus termination to ensure proper communication between the secondary and master modules. It takes the form of an M8 male/M8 female cable that includes a 120 Ω line termination resistor.

It must be integrated on the last secondary of the COVAL bus, between the module's rear connector and the 24 V DC power supply.

When using a stand-alone master module, this termination is not required.



PROFI
NET EtherNet/IP

Common Specifications

- Supply: Non-lubricated air 5 microns filtered, according to standard ISO 8573-1:2010 [4:5:4].
- Operating pressure: 4.5 to 7 bar.
- Mini dynamic pressure:
 - stand-alone module: P = 4.5 bar.
 - island modules: 4 bar.
- Blow-off: adjustable flow:
 - stand-alone version: P = 3.5 bar.
 - island version: P network.
- Maximum vacuum: 85%.
- Suction flow rate: From 29 to 92 NI/min.
- Air consumption: From 44 to 90 NI/min, when operating "without ASC".
- Integrated non-clogging silencer.
- Noise level: approximately 68 dBA "ASC off". 0 dBA with ASC.
- Electric protection grade: IP65.
- Maximum operating frequency: 4 Hz.
- Service life: 30 million cycles.
- Weight: 150 g.
- Operating temperature: From 0 to 50°C.
- Materials: PA 6-6 15% FG, brass, aluminum, NBR.
- 4-pins M8 male connectors.

Self-Adaptation

- Continuous monitoring of the leakage level: Shutoff or automatic return to operation with ASC.

Integrated electronics

- 24 V DC supply (regulated $\pm 10\%$).
- Electric consumption: "master" < 150 mA, "secondary" < 100 mA, of which 30 mA (0.7W) per vacuum and blow-off pilot.
- Measurement range: 0 to 99% vacuum.
- Measurement accuracy: $\pm 1.5\%$ of range, temperature compensated.
- Communication ports protected against wiring errors or reversed polarity.

Service Specifications

Settings

- Piece gripping (L1) and regulation (L2) thresholds.
- Automatic blow-off time configurable (0 to 10 seconds).
- Activation/deactivation of ASC regulation system.
- Activation/deactivation of the (DIAG ECO) leakage level monitoring system.
- Adjustable blue LED functioning mode
- Valve functioning mode in the event of loss of communication

Diagnosis

- Instantaneous vacuum level (0 to 99%).
- Gripped product, loss of product, regulation in process, regulation default information.
- Cycle counters (vacuum, blow-off, gripped piece, ASC, etc.).
- Supply voltage and internal temperature.
- Product reference and serial number.
- Firmware version.

Configuration and diagnosis tools

- LEMCOM Manager PC software (EtherNet/IP, PROFINET and CANopen universal application).
- Embedded web server (EtherNet/IP and PROFINET module).

Communication

EtherNet/IP:

- 2-port ethernet switch.
- Static IP address or DHCP.
- EDS file & RSLogix 5000 Add-On Instructions.

PROFINET:

- 2-port ethernet switch.
- Static IP address or PROFINET DCP.
- GSDML file

COVAL Bus:

- CAN link between "master" and "secondary" units / 1 Mbps.
- Connection by specific bridge for island assembly or unshielded female M8/female M8 cable.
- Max total length of the COVAL Bus: 20 meters.

LEM+

Compact, High Flow Vacuum Pumps

General Information



Industry-specific applications

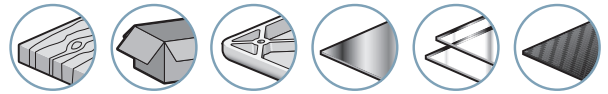

LEM+ Series, compact, high flow vacuum pumps, integrate **ASR** (Air Saving Regulator) technology that allows up to 40% of energy savings. They are designed for gripping porous products or those with a rough surface.

For gripping airtight or semi-airtight products, it is recommended to use the **LEM+ Series**.

Advantages

- Easy implementation: Plug & Play, multiple choices, every type of application.
- Maximum automatic energy savings:
 -  **ASR**: 40% savings for porous products.
- Compactness: LEM+ vacuum pumps are the most compact on the market.
- Short response times: Possible installation very close to vacuum pads.
- Automatic blow-off: Reduced PLC I/O requirement thanks to the automatic blow-off function (blow-off time configurable from 0 to 10s).
- Dust resistant: Non-clogging through-type silencer.
- Safety: Product gripping is maintained even during power failure.



Configurations

- 60% or 85% of maximum vacuum.
- NC or NO, depending on safety.
- Combined **ASR** "venturi regulator".
- With or without visual display.
- With or without vacuum sensor.
- With or without controlled blow-off or automatic blow-off function.
- Powerful blow-off as option.
- Versions with 1 or 2 M12 connectors.
- Suction flow rate (NI/min):

max. vacuum nozzle Ø	60%	85%
2.0 mm	189	125
2.5 mm	275	200

Integration

The **LEM+** compact modules integrate all the functions of "industrial vacuum" including simple, efficient, economical compressed air and are adapted for every application:

- 1 3.5 bar pressure regulator
- 2 "Vacuum" solenoid valve
- 3 3.5 bar optimized venturi
- 4 Optimized silencer
- 5 Electronic vacuum sensor
- 6 Integrated electronics
- 7 "Blow-off" solenoid valve
- 8 Blow-off flow rate regulator

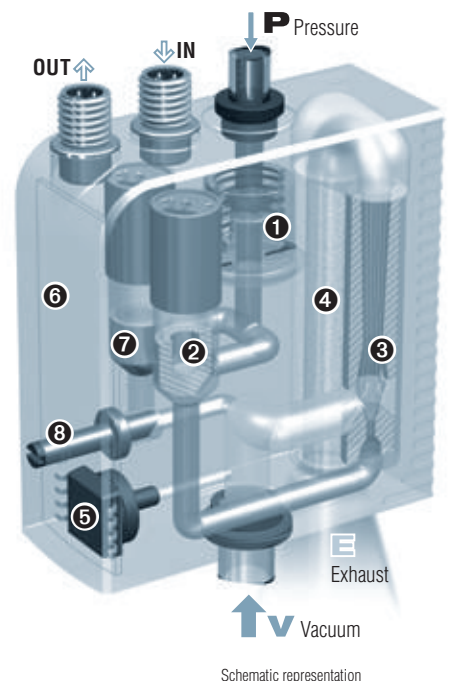
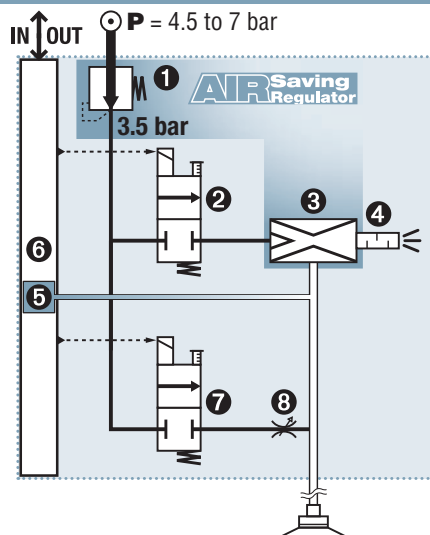

Combined "venturi regulator" **ASR**: pressure regulator 1 feeds venturi 3 with 3.5 bar, optimal for its operation.

→ **No more unnecessary consumption of compressed air.**



40% energy savings
(on average).

8 LEM+

LEM+

Compact, High Flow Vacuum Pumps Energy Savings & Intelligence



AIR Saving Regulator

AIR Saving Regulator (ASR): Air Saving Regulator

The LEM+ vacuum pumps, which integrate an **ASR** "venturi regulator" combination, maintain ideals that COVAL values greatly: reducing both compressed air consumption and noise generation. Regardless of pressure supplied by the compressed air network, the integrated regulator feeds the venturi at **3.5 bar** pressure, optimal for its operation.

- ➔ No more unnecessary energy consumption.
- ➔ No external regulator required and thus the risk of inadvertent misadjustment is eliminated.

Compared to pressures found in most compressed air networks (5-7 bar), the graph opposite demonstrates an achieved economy of 40% on average.

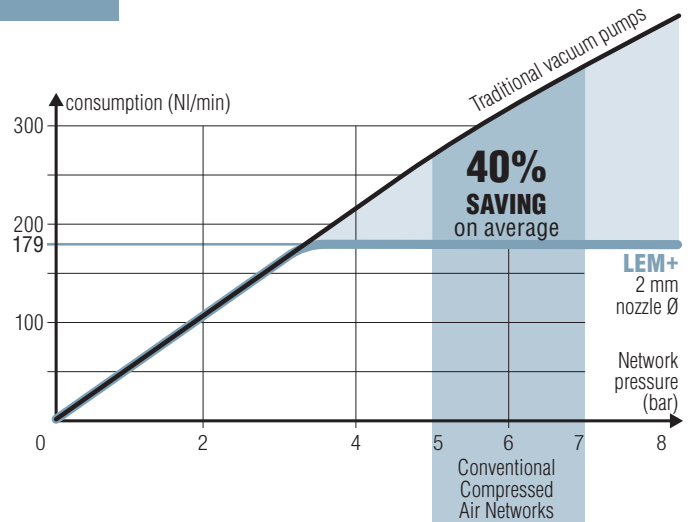

Intelligence

The front communication face panel allows access and programming of all operations: Various types of monitoring, threshold settings, pump configuration, diagnostics, etc. This front face panel can be locked to prevent an inadvertent misadjustment.

Built-in intelligence, as well as standard factory settings, optimize the implementation, operation, monitoring and maintenance.

➔ **Simplified & Protected Installation and Operation.**

Due to the high visibility display of the **LEM+** modules, all useful information can be seen at a single glance: vacuum level, product gripped, thresholds reached, energy saving mode activated, etc.

The actual vacuum level is shown with direct reading (selection of different display units), and with "bar graph".

Configuration help messages (multilingual: in French, English, Italian, Spanish, German) are also provided.

➔ **Clear & Complete Communication at Each Stage.**

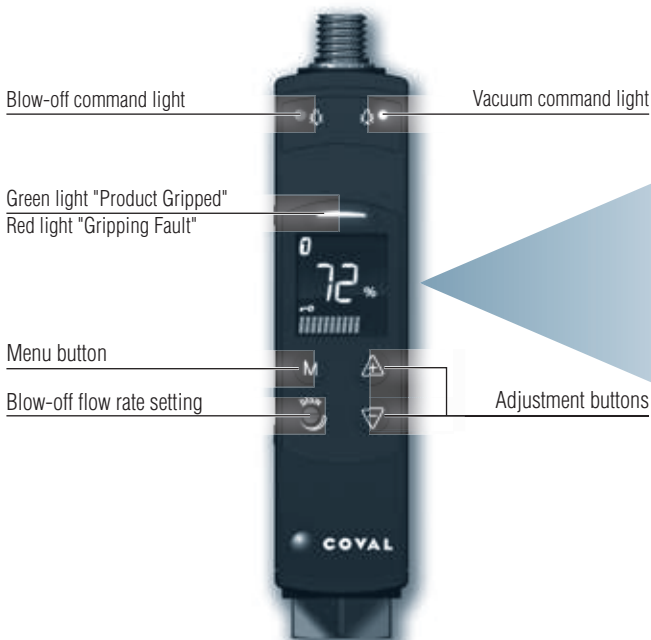

L1 "Product Gripped" visualization and setting: (vacuum threshold, hysteresis)

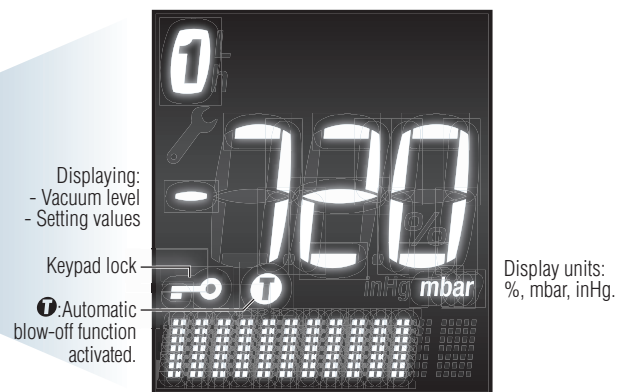

Display shows data in many languages / bar graphs

LEM+ 8



Select Vacuum Level and Nozzle Diameter

The introductory guide in this catalog shows that for porous objects, a 30-55% vacuum is economical and effective. This is obtained with a 60% maximum vacuum pump. The table below helps to select the nozzle diameter which generates enough vacuumed air flow to respond in the time required by the application, based on a measurement of the material's leakage rate.

On the contrary, with an airtight material, the vacuum used is 55% to 80%, obtained by a 85% max. vacuum pump. For standard cases, with its integrated blow-off the **LEM+** series is preferable, and more economical due to its **ASC** (Air Saving Control) function. For special cases, the **LEM+** series contains versions without blow-off and versions without a vacuum switch. The table below helps to select the nozzle diameter required for the application.

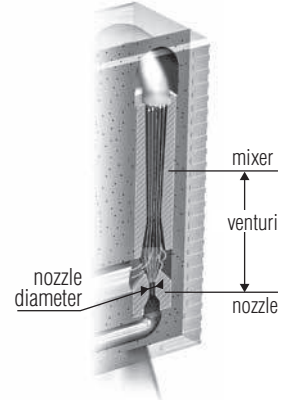

Porous materials:
cardboard, unfinished wood, pastries, etc.

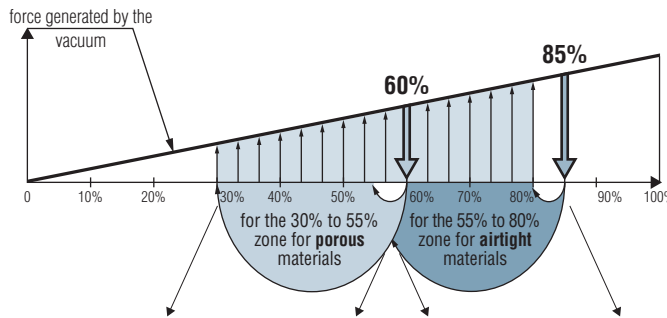
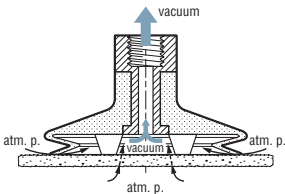

Airtight materials:
glass, plastic, sheet metal, finished wood

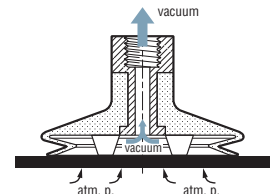

Porous Objects ▶ Maximum Vacuum Level: 60%					
Time to create vacuum (seconds) for a volume of 1 liter					
vacuum achieved	35 %	45 %	55 %	Air consumed (NI/min)	Air drawn in (NI/min)
Ø nozzle					
2.0 mm	0.16	0.27	0.42	179	189
2.5 mm	0.11	0.18	0.31	260	275

Airtight Objects ▶ Maximum Vacuum Level: 85%					
Time to create vacuum (seconds) for a volume of 1 liter					
vacuum achieved	55 %	65 %	75 %	Air consumed (NI/min)	Air drawn in (NI/min)
Ø nozzle					
2.0 mm	0.38	0.55	0.80	179 *	125
2.5 mm	0.26	0.35	0.50	260 *	200

* To save compressed air, choose **LEM+** → **ASC** reduces the air consumption by 90%

8

LEM+

Suction Flow Rate / Vacuum Curves

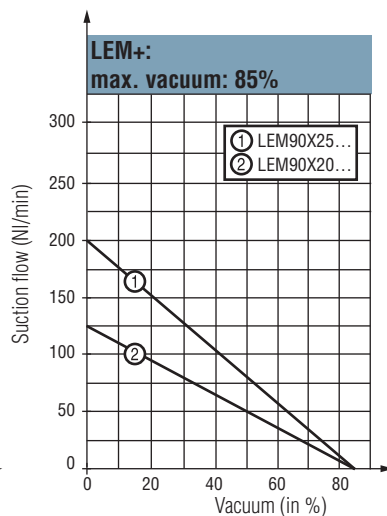
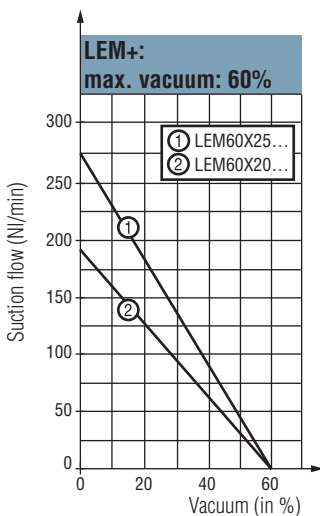

Exhaust manifold: option E

The LEM+ vacuum pumps can be equipped with the "exhaust manifold" option, which provides a G1/2"-F connection to the exhaust in order to add a silencer, transfer the exhaust outside the work area or to avoid air discharge near the workpiece. (LEM__E Version).

This option can be added at a later date by ordering the reference **GVOKITEC2**.

Note: The design of the exhaust manifold and vacuum pumps do not guarantee the complete sealing of the exhaust and therefore cannot be used in a "clean room" environment.

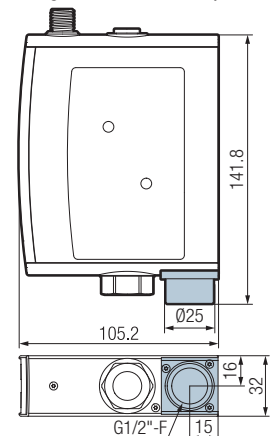



LEM 60 X 25 S VA C15 P G1 F -

VACUUM LEVEL	
60 % max. vacuum is optimal for porous materials	60
85 % max. vacuum is optimal for airtight products	90
NOZZLE DIAMETER	
2 mm nozzle Ø	20
2.5 mm nozzle Ø	25

MODULE COMPOSITION		
NC Vacuum Pump Without Blow-Off LEM_X_RV_C_PG1		R
<ul style="list-style-type: none"> Single command signal. NC vacuum command valve. 		
NC Vacuum Pump With Blow-Off LEM_X_SV_C_PG1		S
<ul style="list-style-type: none"> 2 command signals. NC vacuum command valve. Blow-off configured on site, at choice: <ul style="list-style-type: none"> Blow-off controlled by specific signal; Automatic blow-off function (blow-off time configurable from 0 to 10s), only with VA option (advantage: reduced PLC I/O requirement). Adjustable blow-off flow rate. 		
NO Vacuum Pump With Blow-Off LEM_X_VV_C_PG1		V
<ul style="list-style-type: none"> 2 command signals. NO vacuum command valve. Blow-off controlled by external signal. Adjustable blow-off flow rate. 		
Safety in Case of Power Failure		
This version is suitable for applications where product gripping safety must be ensured in the event of an untimely power failure, and this even in the case of leakage (failsafe). This version does not include automatic blow-off function that enables control of the module with a single "vacuum and blow-off" signal.		

VACUUM SENSOR DIALOGUE

Vacuum pump without vac. sensor **VO C14** one M12 connector 4 pins (C14)
LEM_X_VOC14PG1

- Simplified LEM+ without settings and dialogue.
- Automatic operation until maximum vacuum level.

Vacuum pump with vacuum sensor & dialogue **VA C15** one M12 connector 5 pins (C15)
LEM_X_VAC15PG1

- Electronic vacuum sensor (VA).
- "Gripped product" switching output 24V DC / NO.
- Front face panel and full dialogue.

Vacuum pump with vacuum sensor & dialogue **VA C24** two M12 connectors 4 pins (C24)
LEM_X_VAC24PG1

- Electronic vacuum sensor (VA).
- Stand alone I/O.
- "Gripped product" switching output 24V DC / NO.
- 1 auxiliary output: "Vacuum level" signal analogic 1 to 5V DC.
- Front face panel with full dialogue.

POWERFUL BLOW-OFF

Without	-
With	F

The powerful blow-off option allows you to release the product quickly. Isolation valve **F** directs the entire blow-off flow to the vacuum pad. The option is only available with LEM+ modules equipped with a blow-off regulation: Version LEM_X_SV... and LEM_X_VV...
NB: If option **F** is selected, no blow-off flow rate setting is available.

EXAMPLE OF COMPLETE PART NUMBER: LEM60X25SVAC15PG1
LEM+ vacuum pump, 60% maximum vacuum, 2.5 mm nozzle Ø, controlled by a NC (Normally Closed) solenoid valve with vacuum sensor and dialogue, connection by 1 M12 5-pin connector.

EXHAUST	
Open (integrated silencer)	-
Exhaust manifold (G1/2"-F)	E



Side Mounting

▪ Version: one M12 connector

▪ Version: two M12 connectors

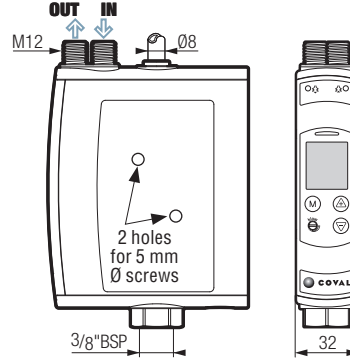
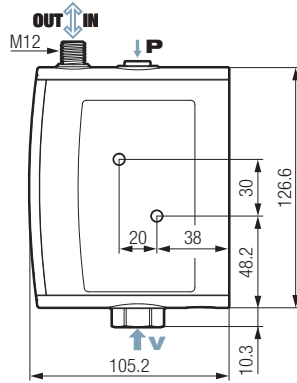

Mounting from the side is the simplest to implement: Two \varnothing 5 mm through screws or bolts with large washers.

Mounting from Front

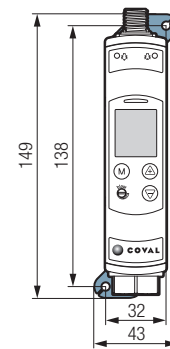
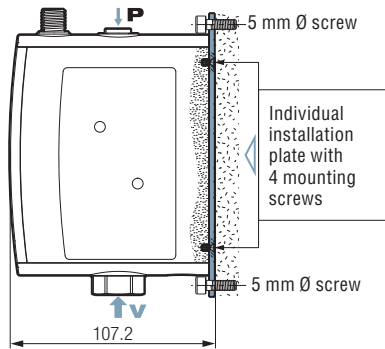

For mounting from the front, in addition to the module, you need to order an additional kit:

Mounting from front kit:
1 plate + 4 screws

Part No.: LEMFIX2A

8

LEM+

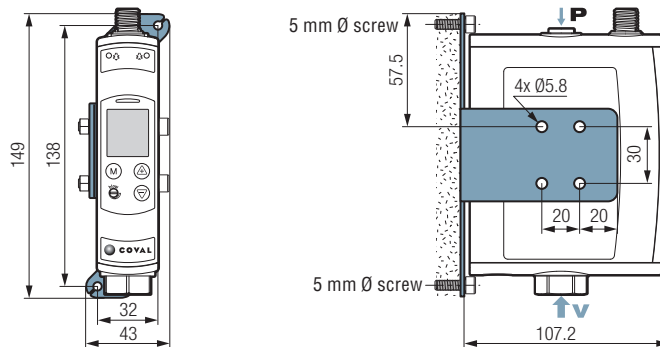

For front installation with side pump mounting this kit is needed in addition to the module:

Front installation kit:
1 bracket + 2 screws CHC5x40 + 2 nuts

Part No.: LEMFIX2D

Mounting on DIN rail

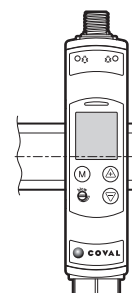
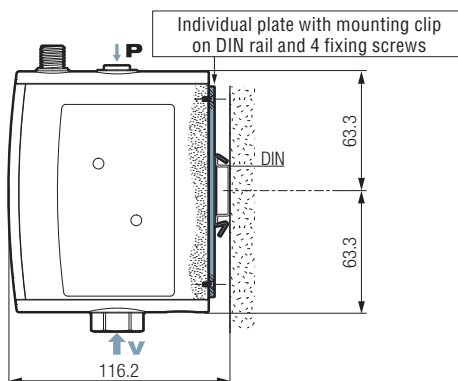

For a static mounting (for example, in a cabinet), a module can be clipped onto a DIN rail. For this purpose, the module must first be equipped with an individual plate for fixing onto a DIN rail, to be ordered separately:

Kit for mounting on DIN rail:
1 plate / clip + 4 screws

Part No.: LEMFIX2B



Specifications

COMMON SPECIFICATIONS

- Supply: Non-lubricated air 5 microns filtered, according to ISO 8573-1:2010 [4:5:4].
- Operating pressure: 4.5 to 7 bar.
- Blow-off: Adjustable flow rate.
- Powerful blow-off (option **F**) P = 3.5 bar without flow rate control.
- Maximum vacuum: 60% or 85% depending on model.
- Suction flow rate: From 125 to 275 NI/min, depending on model.
- Air consumption: From 179 to 260 NI/min, depending on model.
- Integrated non-clogging silencer.
- Sound level: From 72 to 75 dBA.
- Display status:
 - of the vacuum control on the front panel: Green LED.
 - of the blow-off control on the front panel: Orange LED.
- Electric protection grade: IP 65.
- Maximum operating frequency: 4 Hz.
- Response time for opening / closing: 20/30 ms.
- Service life: 30 million cycles.
- Weight: From 410 to 460 g, depending on model.
- Operating temperature: From 0 to 50°C.
- Materials: PA 6-6 15% FG, brass, aluminum, NBR, HNBR, PU.

Electrical Controls

- Control voltage: 24V DC ($\pm 10\%$ regulated).
- Current consumption: 30 mA (0.7W) by vacuum or blow-off solenoid valve.

VA MODEL SPECIAL SPECIFICATIONS

Displays

- Display status of the threshold on the front panel: Green or red LED.
- Black and white LCD display, 7 matrix, symbols, vacuum reading area.
- Displaying the vacuum level and bar graph.
- Displaying number of cycles (vacuum cycles counter).
- Indication of exceeding service life (> 30 million cycles).

Settings

- Using membrane keypad and pull down menu.
- Language selection: FR, ENG, DE, IT or ES.
- Blow-off type selection: controlled or automatic (blow-off time configurable from 0 to 10s).
- Measurement unit selection (% , mbar, inHg).
- Manual, electrical, monostable commands.
- If the application requires, specific setting of thresholds and hysteresis that are different from the initial factory settings: L1 = 65%, h1 = 10%).

Vacuum Sensor

- Power supply voltage: 24V DC ($\pm 10\%$ regulated).
- Current consumption: Standby: <25mA / max. 60 mA.
- Measurement range: 0 to 99% of vacuum, 0 to -999 mbar, 0 to -29.9 inHg.
- Measurement accuracy: $\pm 1.5\%$ of range, temperature compensated.

"Gripped Product" Output Signal

- 24V DC, switching output / NO, switching capacity: 125 mA PNP.
- Auxiliary output** (C24 model only, 2 x M12 4 pins)
 - "Vacuum level" signal, analogic 1 to 5V DC of measuring range.

Electrical Connections

- C14:** 1 M12 4-pin connector

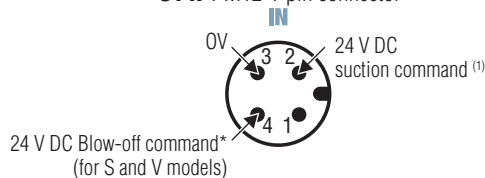

- C15:** 1 M12 5-pin connector

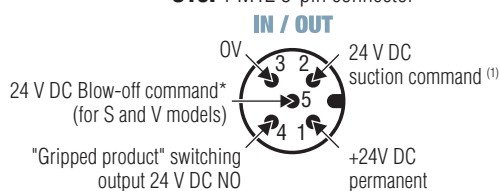

- C24:** 2 M12-4 pin connector

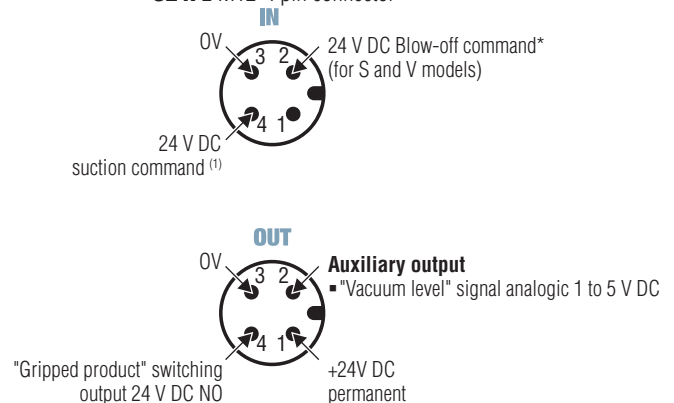

(1) 24 V DC suction command, depending on version:
 - for vacuum pumps model **R** and **S** (vacuum control NC valve): 24 V DC vacuum control
 - for vacuum pumps Model **V** (vacuum control NO valve): 24 V DC vacuum off command
 * **S** externally controlled blow-off or automatic blow-off function > economy of an automaton outlet.

Accessories

Power supply cable: M12, straight, female – open end

- CDM12N:** 4-pin, length. 2 m.
- CDM12L5:** 4-pin, length. 5 m.
- CDM125PL2:** 5-pin, length. 2 m.
- CDM125PL5:** 5-pin, length. 5 m.



Power supply cable: M12, elbow, female – open end

- CCM12:** 4-pin, length. 2 m.
- CCM125PL2:** 5-pin, length. 2 m.



LEMAX+

Compact, High Flow Vacuum Pumps

General Information

LEMAX+ Series, compact, high flow vacuum pumps, integrate ASC (Air Saving Control) technology that allows up to 90% of energy savings. They are specifically designed for gripping airtight or semi-airtight products.

For gripping porous products or those with a rough surface, it is recommended to use the **LEM+** Series.

Advantages

- Easy implementation: Plug & Play, multiple choices, every type of application.
- Maximum automatic energy savings:
 -  **ASC**: 90% savings for airtight products.
- Compactness: **LEMAX+** vacuum pumps are the most compact on the market.
- Short response times: Possible installation very close to vacuum pads.
- Automatic blow-off: Reduced PLC I/O requirement thanks to the automatic blow-off function (blow-off time configurable from 0 to 10s).
- Dust resistant: Non-clogging through-type silencer.
- Safety: Product gripping is maintained even during power failure.

Configurations

- 85% of maximum vacuum.
- NC or NO, depending on safety.
- ASC advanced electronics.
- High visibility display.
- Integrated vacuum sensor.
- Vacuum non-return valve.
- Combined **ASR** "venturi regulator".
- External blow-off signal or automatic blow-off function.
- Powerful blow-off as option.
- Versions with 1 or 2 M12 connectors.
- Suction flow rate (NI/min):

nozzle Ø	max. vacuum	85%
2.0 mm	125	
2.5 mm	200	

AIR Saving Control

Industry-specific applications

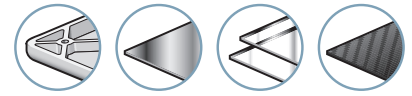

8 LEMAX+

Integration

The **LEMAX+** compact modules integrate all the functions of "industrial vacuum" including simple, efficient, economical compressed air usage and are adapted for every application:

- 1 3.5 bar pressure regulator
- 2 "Vacuum" solenoid valve
- 3 3.5 bar optimized venturi
- 4 Optimized silencer
- 5 Electronic vacuum sensor
- 6 Integrated electronics
- 7 "Blow-off" solenoid valve
- 8 Blow-off flow rate regulator
- 9 Vacuum non-return valve

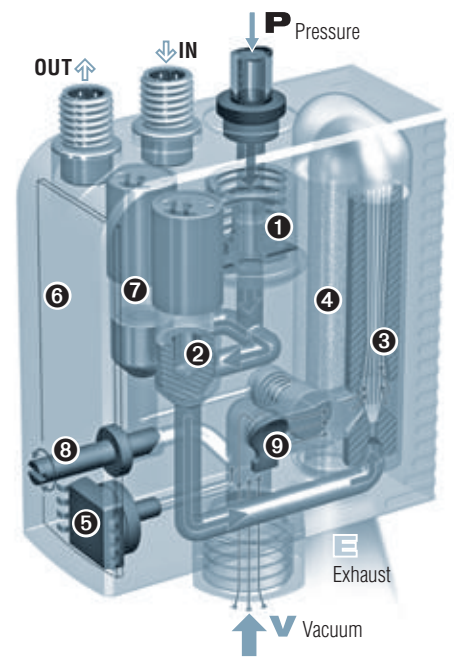
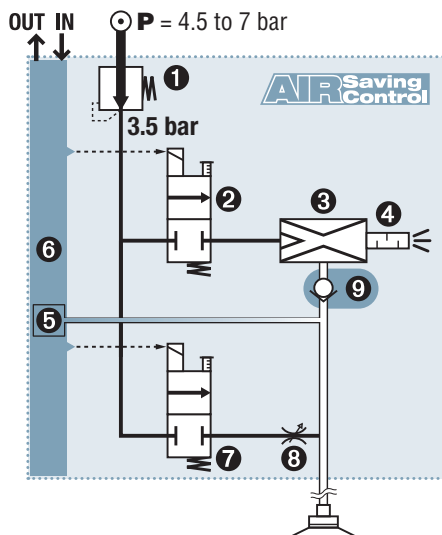

Combination of non-return **9** and advanced electronics **6** ensures the ASC's automatic management.

→ Once vacuum is established, the pump does not continue to consume air to hold the product.

AIR Saving Control

90% energy savings (on average).

LEMAX+

Compact, High Flow Vacuum Pumps

Energy Saving & Auto-adjustment



AIR Saving Control

AIR Saving Control "Air Saving Control" Cycle

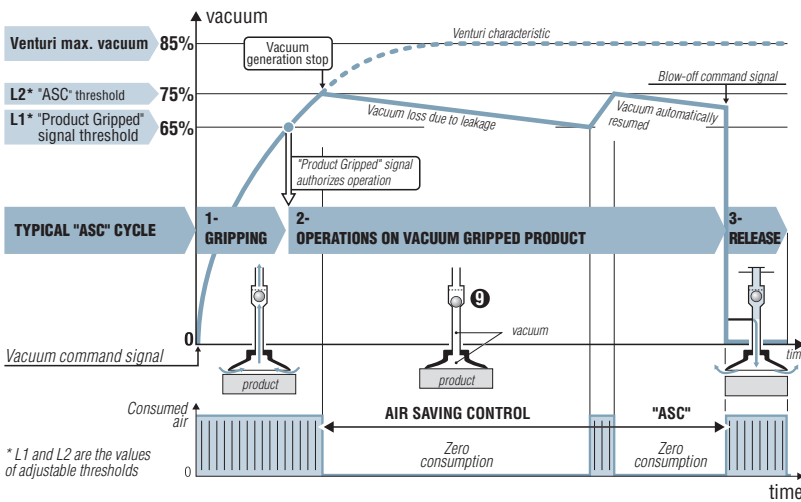

As illustrated in the above figure, the LEMAX module automatically executes the "ASC", cycle, thus saving the maximum amount of energy, based on the following 3 phases.

1- Gripping the object

The "vacuum" solenoid ② starts the cycle by supplying the venturi ③ which generates the vacuum to quickly pick up the object with the suction cup → short-term consumption.

2- Operations on the object held by vacuum

The vacuum level is constantly monitored by the vacuum switch ④. When it reaches the L1 threshold (65%), the "gripped object" signal is generated, which allows the planned operations (transfer, machining, etc.). When the vacuum reaches threshold L2 (75%), the supply to the venturi via the solenoid valve ② is cut off → consumption is halted. The object remains held by the vacuum maintained thanks to the closed valve ④.

Micro-leaks will generally cause the vacuum level to fall slowly. Each time it falls below 65%, vacuum generation is briefly resumed until it reaches threshold L2 (75%).

3- Releasing the object

At the end of operations, blow-off is ordered. The "blow-off" solenoid valve ⑦ generates a stream of air which closes the isolation valve ④, blows on the object to release it quickly.

Smart Adaptation

The illustration below shows the adaptation capacities of the LEMAX module. "ASC" operation is automatic for any object that is air-tight enough (cycle 1).

If a leak occurs (cycle 2), due to a rough object or to suction-pad wear, the module automatically detects the anomaly, ends the cycle without "ASC" in order to continue production and reports the event for possible maintenance. Production continues. Once everything is returned to normal (cycle 3), "ASC" operation is automatically resumed.

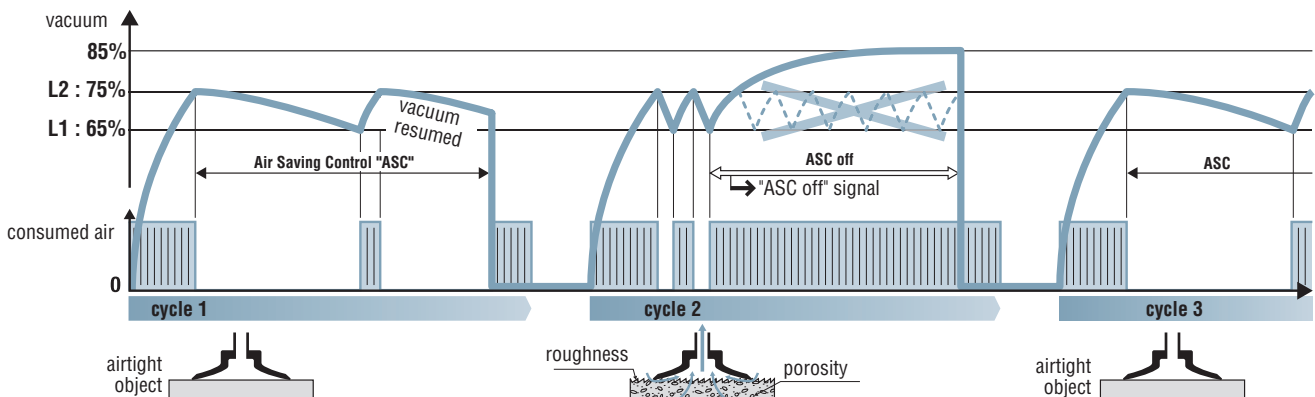

1- Gripping + transfer (2 mm nozzle Ø, emptying 0.2 l)

Phase	Duration	Air consumption		achieved economy
		without "ASC"	with "ASC"	
Gripping	0.16 s	0.45 NI	0.45 NI	80 %
Transfer	1.20 s	3 NI	0	
Release	0.14 s	0.3 NI	0.3 NI	
		3.75 NI	0.75 NI	

2- Clamping + operations (2 mm nozzle Ø, emptying 0.4 l)

Phase	Duration	Air consumption		achieved economy
		without "ASC"	with "ASC"	
Clamping	0.32 s	0.9 NI	0.9 NI	99 %
Operations	60 s	179 NI	0	
Release	0.14 s	0.3 NI	0.3 NI	
		180.2 NI	1.2 NI	

Resulting Savings

Energy savings from "ASC" are major, as the two examples above show:

- 80 % savings for transferring an object after gripping.
- 99 % savings for holding an object during a 1 minute operation.

The investment generally pays for itself in just a few months.

"ASC": AN ADVANTAGE WITHOUT LIMITATIONS

Saving energy has become essential. With LEMCOM, thanks to ASC, energy is automatically saved without interfering with established operations:

1- No specific adjustment

The initial setting (L1 = 65%, L2 = 75%) is suitable for most applications.

2- Production regardless of what happens

Operation is always ensured, if necessary without "ASC", if the leakage level is too high.

3- Guided maintenance

Clear display of the need for maintenance to return to auto-regulated "ASC" operation.

8
LEMAX+



Specially designed by COVAL, the LEMAX+ vacuum pumps integrate the ASR (regulator-venturi) combination which greatly reduces the compressed air consumption and noise level.

LEM MAX+

Compact, High Flow Vacuum Pumps

Intelligence & Selection Guide



Intelligence

The front communication face panel allows access and programming of all operations: Various types of monitoring, threshold settings, pump configuration, diagnostics, etc. This front face panel can be locked to prevent an inadvertent misadjustment.

Built-in intelligence, as well as standard factory settings, optimize the implementation, operation, monitoring and maintenance.

→ Simplified & Protected Installation and Operation.

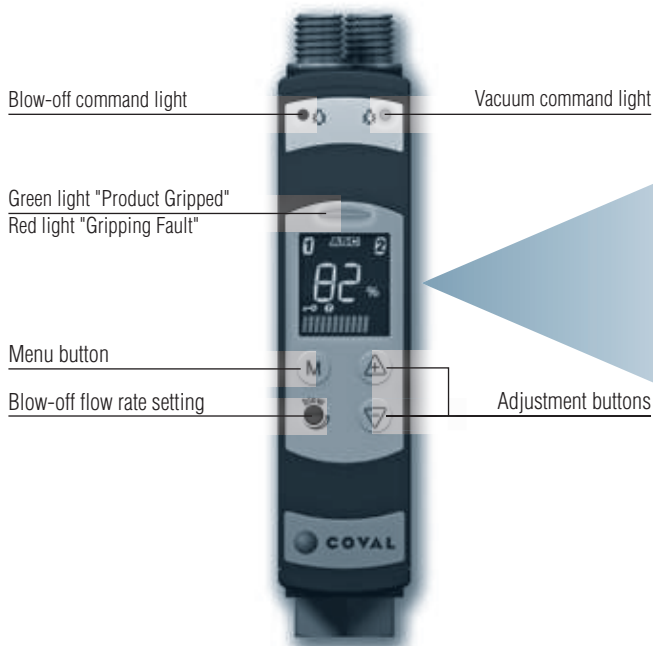

Due to the high visibility display of the **LEM MAX+** modules, all useful information can be seen at a single glance: vacuum level, product gripped, thresholds reached, energy saving mode activated, etc.

The actual vacuum level is shown with direct reading (selection of different display units), and with "bar graph".

Configuration help messages (multilingual: in French, English, Italian, Spanish, German) are also provided.

→ Clear & Complete Communication at Each Stage.

L1 "Product Gripped" visualization and setting: (vacuum threshold, hysteresis)
 "ASC" monitoring
 L2 "ASC Threshold" visualization and setting: (vacuum threshold, hysteresis)

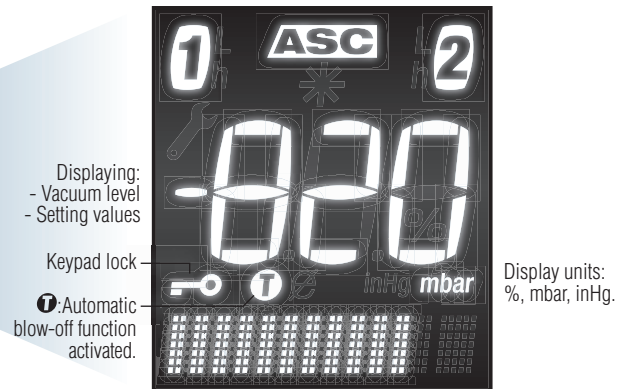

Display shows data in many languages / bar graphs

8

LEM MAX+

Power Determined by the Venturi Nozzle Diameter

The table shows the power levels generated by each of the nozzle diameters available: when the module is operating "ASC" off, a larger nozzle draws and consumes more compressed air.

On the other hand, during "ASC" operation, a large nozzle quickly reaches the vacuum threshold generating power shut-off.

In conclusion:

- A large nozzle enables quicker gripping without consuming more during "ASC" operation.
- A small nozzle does not consume less when operating with "ASC" off.

nozzle Ø	Nozzle Diameter Selection				
	Venturi Specifications While Working Without "ASC"		Evacuation of 1L Volume. "ASC" Operation:		
	Vacuum flow (NI/min)	Consumed Air (NI/min)	Gripping Time (65% Vacuum) (s)	Time Until 75% Vacuum (s)	Consumed Air (NI)
2.0 mm	125	179	0.55	0.80	2.2
2.5 mm	200	260	0.35	0.50	2.2

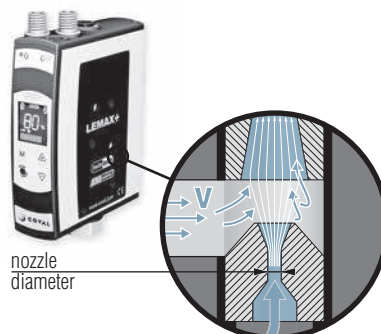

Suction Flow Rate / Vacuum Curves

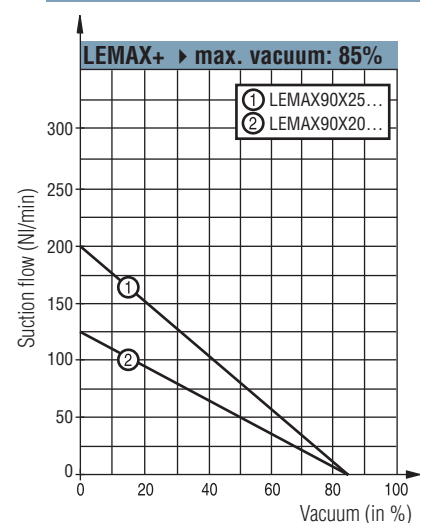



LEMAX 90 X 25 S C15 P* G1 F -

VACUUM LEVEL
85 % max. vacuum is optimal for airtight products
90

NOZZLE DIAMETER
2 mm nozzle Ø **20**
2.5 mm nozzle Ø **25**

MODULE COMPOSITION

NC Vacuum Pump With Blow-Off

LEMAX__X__SV_C__PG1

- 2 command signals.
- NC** vacuum command valve.
- Blow-off configured on site, at choice:
 - Blow-off controlled by specific signal;
 - Automatic blow-off function (blow-off time configurable from 0 to 10s.).
- Advantage: reduced PLC I/O requirement.
- Adjustable blow-off flow rate.

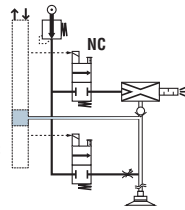

S

NO Vacuum Pump With Blow-Off

LEMAX__X__VV_C__PG1

- 2 command signals.
- NO** vacuum command valve.
- Blow-off controlled by external signal.
- Adjustable blow-off flow rate.

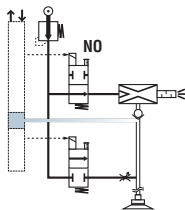

V

Safety in Case of Power Failure

This version is suitable for applications where product gripping safety must be ensured in the event of an untimely power failure, and this even in the case of leakage (failsafe).

This version does not include automatic blow-off function that enables control of the module with a single "vacuum and blow-off" signal.

EXAMPLE OF COMPLETE PART NUMBER:

LEMAX90X25SC24PG1

LEMAX+ vacuum pump, 85% maximum vacuum, 2.5 mm nozzle Ø, controlled by a NC (Normally Closed) solenoid valve, connection by 2 M12 4-pin connectors.

CONNECTORS

C15 Vacuum Pump with 1 M12 5-pin Connector
LEMAX90X__C15PG1



- "Gripped product" switching output 24V DC / NO.

C24 Vacuum Pump with 2 M12 4-pin Connectors
LEMAX90X__C24PG1



- Stand alone I/O.
- "Gripped product" switching output 24V DC / NO.
- 1 configurable auxiliary output:
 - either "Vacuum level" signal analogic 1 to 5V DC.
 - or "Without ASC" signal +5V DC switching output NO.

*P = PNP electronic
→ NPN version available upon request.

POWERFUL BLOW-OFF

- Without
- F** With

The powerful blow-off option allows you to release the product quickly.

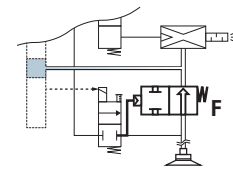

Isolation valve **F** directs the entire blow-off flow to the vacuum pad.

NB: If option **F** is selected, no blow-off flow rate setting is available.

EXHAUST

- Open (integrated silencer) -
- Exhaust manifold (G1/2"-F) **E**

The LEMAX+ vacuum pumps can be equipped with the "exhaust manifold" option, which provides a G1/2"-F connection to the exhaust in order to add a silencer, transfer the exhaust outside the work area or to avoid air discharge near the work-piece. (LEMAX__E Version).

This option can be added at a later date by ordering the reference **GVOKITEC2**.

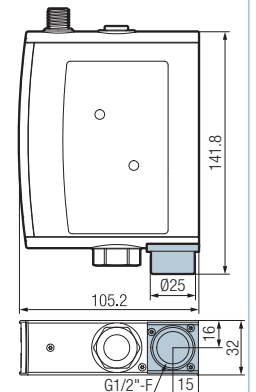

Note: The design of the exhaust manifold and vacuum pumps do not guarantee the complete sealing of the exhaust and therefore cannot be used in a "clean room" environment.

LEMAX+

Compact, High Flow Vacuum Pumps

Dimensions, Mounting Options



Side Mounting

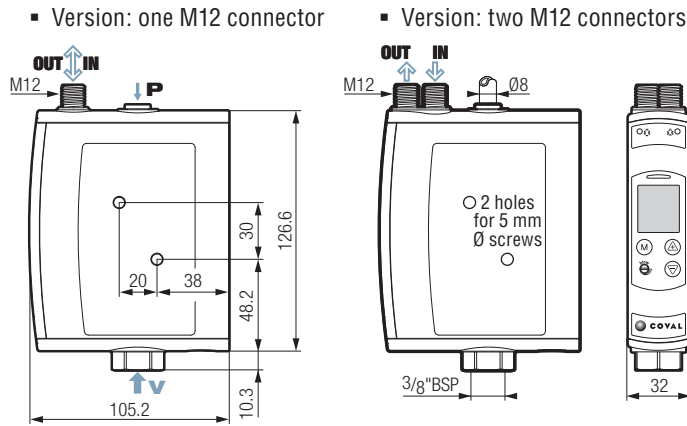

Mounting from the side is the simplest to implement: Two \varnothing 5 mm through screws or bolts with large washers.

Mounting from Front

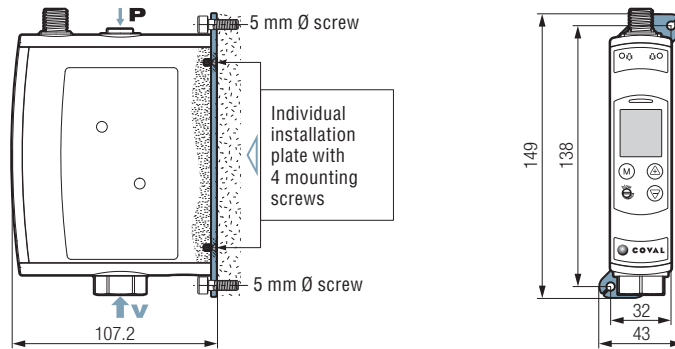

For mounting from the front, in addition to the module, you need to order an additional kit:

Mounting from front kit:
1 plate + 4 screws

Part No.: LEMFIX2A

8

LEMAX+

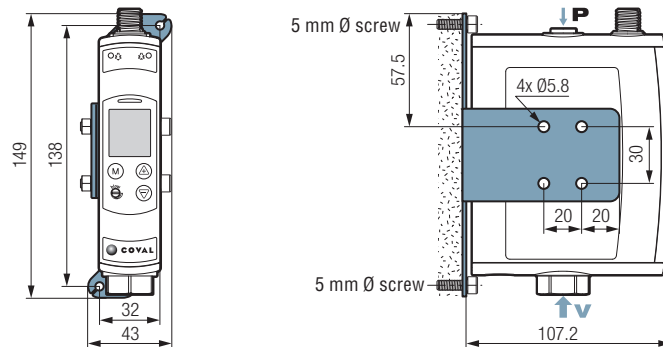

For front installation with side pump mounting this kit is needed in addition to the module:

Front installation kit:
1 bracket + 2 screws CHC5x40 + 2 nuts

Part No.: LEMFIX2D

Mounting on DIN rail

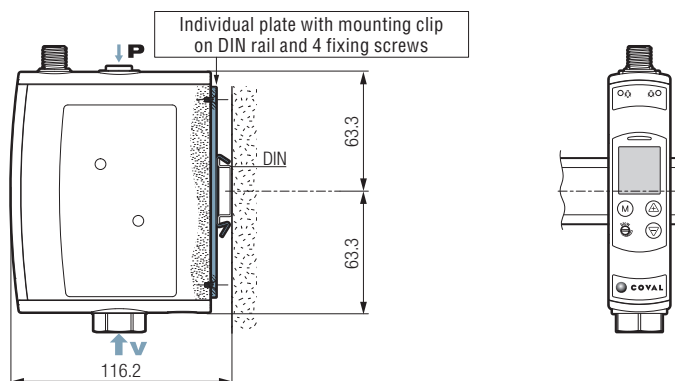

For a static mounting (for example, in a cabinet), a module can be clipped onto a DIN rail. For this purpose, the module must first be equipped with an individual plate for fixing onto a DIN rail, to be ordered separately:

Kit for mounting on DIN rail:
1 plate / clip + 4 screws

Part No.: LEMFIX2B



Specifications

- Supply: Non-lubricated air 5 microns filtered, according to standard ISO 8573-1:2010 [4:5:4].
- Operating pressure: 4.5 to 7 bar.
- Blow-off: Adjustable flow rate.
- Powerful blow-off (option F) P = 3.5 bar without flow rate control.
- Maximum vacuum: 85%.
- Suction flow rate: From 125 to 200 NI/min, depending on model.
- Air consumption: From 179 to 260 NI/min, depending on model (when operating "without ASC").
- Integrated non-clogging silencer.
- Sound level: From 72 to 75 dBA "without ASC". 0 dBA with ASC available.
- Display status:
 - of the vacuum control on the front panel: Green LED.
 - of the blow-off control on the front panel: Orange LED.
- Electric protection grade: IP 65.
- Maximum operating frequency: 4 Hz.
- Response time for opening / closing: 20/30 ms.
- Service life: 30 million cycles.
- Weight: From 410 to 460 g, depending on model.
- Operating temperature: From 0 to 50°C.
- Materials: PA 6-6 15% FG, brass, aluminum, NBR, HNBR, PU.

Electrical Controls

- Control voltage: 24V DC ($\pm 10\%$ regulated).
- Current consumption: 30 mA (0.7W) by vacuum or blow-off solenoid valve.

Displays

- Display status of the threshold on the front panel: Green or red LED.
- Black and white LCD display, 7 matrix, symbols, vacuum reading area.
- Displaying the vacuum level and bar graph.
- Displaying number of cycles (vacuum cycles counter).
- Indication of exceeding service life (> 30 million cycles).

Settings

- Using membrane keypad and pull down menu.
- Language selection: FR, ENG, DE, IT or ES.
- Blow-off type selection: controlled or automatic (blow-off time configurable from 0 to 10s).
- Measurement unit selection (% , mbar, inHg).
- Manual, electrical, monostable commands.
- If the application requires, specific setting of thresholds and hysteresis that are different from the initial factory settings: L1 = 65%, h1 = 10%.

Vacuum Sensor

- Power supply voltage: 24V DC ($\pm 10\%$ regulated).
- Current consumption: Standby: <25mA / max. 60 mA.
- Measurement range: 0 to 99% of vacuum, 0 to -999 mbar, 0 to -29.9 inHg.
- Measurement accuracy: $\pm 1.5\%$ of range, temperature compensated.

"Gripped Product" Output Signal

- 24V DC, switching output / NO, switching capacity: 125 mA PNP.

Configurable auxiliary output

- (C24 model only, 2 x M12 4 pins)
- either "Vacuum level" signal, analogic 1 to 5V DC of measuring range.
 - or "without ASC" signal +5V DC NO switching output.

ASC: Regulation & Self-Adaptation

- Continuous monitoring of the leakage level: Back-off or automatic return to operation with ASC.

Electrical Connections

- C15:** 1 M12 5-pin connector

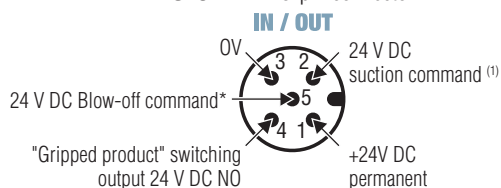

- C24:** 2 M12-4 pin connector

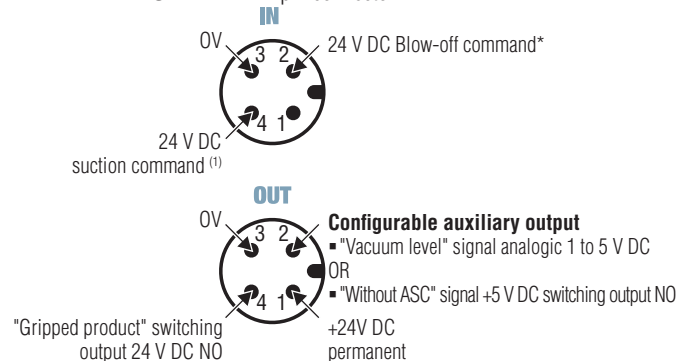

(1) 24 V DC suction command, depending on version:
 - for vacuum pumps model **S** (vacuum control NC valve): 24 V DC vacuum control
 - for vacuum pumps Model **V** (vacuum control NO valve): 24 V DC vacuum off command

* **S** externally controlled blow-off or automatic blow-off function > economy of an automaton outlet.

Accessories

Power supply cable: M12, straight, female – open end

- CDM12N:** 4-pin, length. 2 m.
- CDM12L5:** 4-pin, length. 5 m.
- CDM125PL2:** 5-pin, length. 2 m.
- CDM125PL5:** 5-pin, length. 5 m.



Power supply cable: M12, elbow, female – open end

- CCM12:** 4-pin, length. 2 m.
- CCM125PL2:** 5-pin, length. 2 m.



GVMAX HD

Heavy Duty Communicating Vacuum Pumps

General Information

COVAL's **GVMAX HD** series Heavy Duty communicating vacuum pumps are the result of many years of listening, discussions and feedback from manufacturers, integrators and users from the automotive, aerospace and packaging industries.

Our **GVMAX HD** vacuum pumps meet their expectations in terms of power, robustness, ease-of-configuration and use, communication and modularity, all while remaining compact and light for easy integration in a smart factory.

Advantages

- Robust: Resistant to the harsh environments of metal stamping and sheet metal production lines
- High performance: Optimized Venturi system that guarantees powerful suction flow rates and reduced evacuation times
- Modular: Easy maintenance; SMART SWAP quick-mounting system
- Communicating: Efficient communication system for all use levels, clear and easy-to-read HMI, NFC technology for mobile use, and IO-Link communications interface for straightforward networking

Main Specifications

- 85% vacuum
- Vacuum control: NC, NO or pulse-triggered bistable control
- Powerful suction flow rates:
 - Dia. 2.5 mm nozzle → 185 NI/min
 - Dia. 3.0 mm nozzle → 230 NI/min
- Blow-off: Standard or powerful, controlled or automatic timed
- Non-return valve
- 1 or 2 M12 connectors
- Degree of protection: IP65
- Standalone vacuum pumps or in island assemblies
- High-visibility color display with clear multi-lingual messages and straightforward settings menu
- Remote HMI available depending on version
- Easy set up made possible by NFC technology and COVAL Vacuum Manager mobile application
- IO-Link communications interface
- Air Saving Control (ASC) smart vacuum control system guarantees 90% energy savings on average
- Supply pressure monitoring (pressure sensor)
- Vacuum network status analysis and monitoring



NFC)))



Industry-specific applications

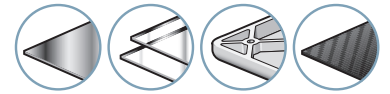

NFC)))

IO-Link



8

GVMAX HD



Safety, Productivity, and Flexibility at every step of manufacturing

COVAL provides the various players in the automotive industry a global approach to vacuum handling for all their gripping, moving, placing, and holding needs for varied body parts, glass, and accessories.

COVAL solutions, such as vacuum pumps and suction cups, are equipped on robots for stamping presses, welding, assembly, and glass production.

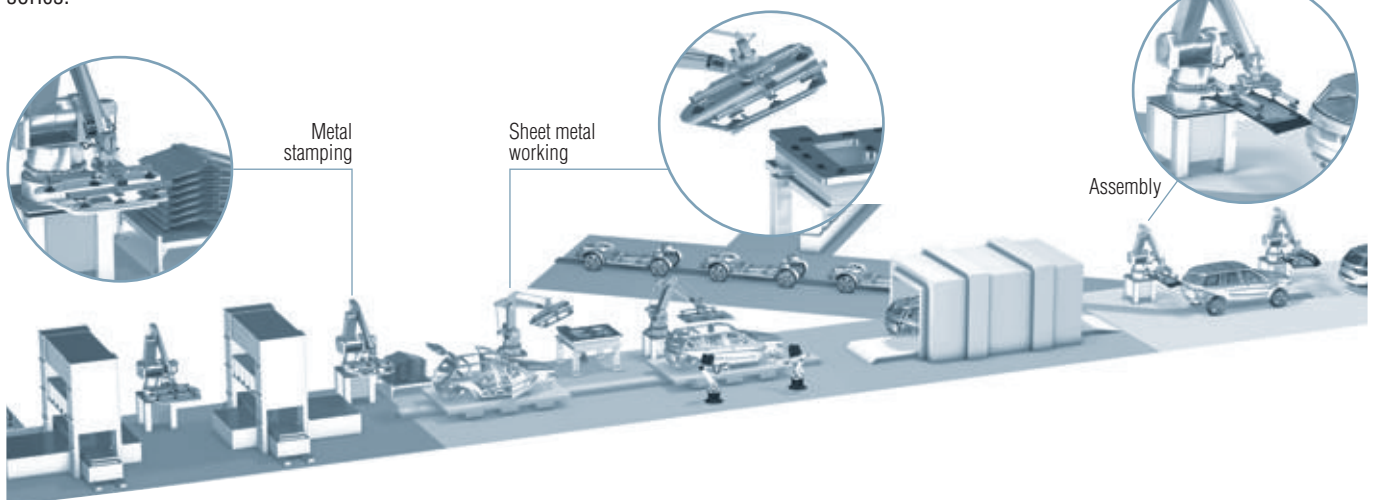

GVMAX HD

Heavy Duty Communicating Vacuum Pumps

General Information



NFC)))
IO-Link
AIR Saving Control

GVMAX HD Makes Vacuum Management Easy



Onboard installation and diagnostic tools:

- Vacuum network sizing support and clogging detection
- Compressed air consumption monitoring
- Supply voltage monitoring



Inputs / Outputs
Digital (SIO) / IO-Link

M12 connectors available in 4 versions:

- One 5 or 8-pin connector
- or two 4 or 5*-pin connectors

*Version for use with remote HMI



3-color status indicator light

1.54" high-visibility color LCD display with clear multilingual messages and straightforward settings menu

Settings keypad



NFC)))

Straightforward setup and diagnostics made possible by NFC technology and COVAL Vacuum Manager mobile application.



SMART SWAP Quick-mounting system: Allows you to mount the GVMAX HD module onto its pneumatic socket or remove it in the blink of an eye, without needing to disconnect compressed air and vacuum tubes.



Pneumatic socket: Combines the compressed air supply and the vacuum outlet

- NC, NO or pulse-triggered bistable vacuum control
- Blow-off: Standard or powerful, controlled or automatic timed



Vacuum generation with single-stage Venturi pump

- Short evacuation times
- No moving parts
- Dust resistant
- No maintenance required



AIR Saving Control Air Saving Control (ASC), our smart vacuum control system: Averages 90% energy savings



Open clog-free silencer

GVMAX HD 8

GVMAX HD

Heavy Duty Communicating Vacuum Pumps

Integration and Performance



NFC)))
IO-Link
AIR Saving Control

Integrated Functions

GVMAX HD vacuum pumps include all the “vacuum” functions required for an easy, efficient and economical use of compressed air and suitable for any application:

- ❶ “Vacuum” solenoid valve
- ❷ Single-stage Venturi pump
- ❸ Open silencer
- ❹ “Vacuum” non-return valve
- ❺ Electronic vacuum switch
- ❻ Integrated electronics
- ❼ Pressure sensor
- ❽ “Blow-off” solenoid valve
- ❾ 350 µm filter screen



90% energy savings
(on average, see p. 8/56)

The combined action of the non-return valve ❹ and of the integrated electronics ❻ automatically ensures ASC management.
→ **Once the vacuum has been established, the pump does not consume any more air to hold the object.**

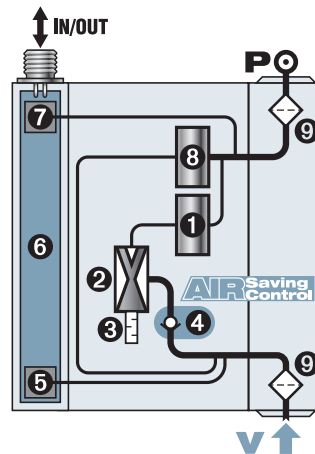

Performance determined by the Venturi pump's nozzle diameter

The table specifies the performance levels and evacuation times generated for each nozzle diameter available.

When handling airtight objects, the ASC vacuum control system can help to considerably reduce the consumption of compressed air.

Nozzle dia.	Vacuum reached	Evacuation time (seconds) of a volume of 1 liter				Max. vacuum (%)	Air drawn in (NI/min)	Air consumed (NI/min)	Air pressure level (bar)
		45 %	55 %	65 %	75 %				
2.5 mm		0.17	0.24	0.35	0.52	85	185	294	5
3.0 mm		0.15	0.20	0.27	0.42	85	230	380	5.5

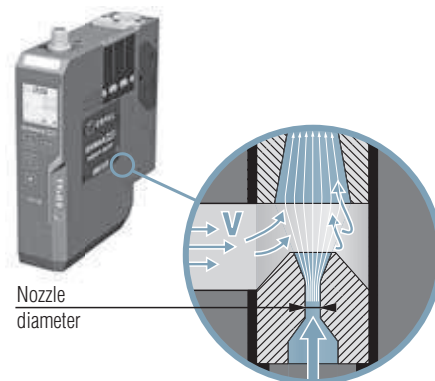

8 GVMAX HD

Vacuum Generated/Compressed Air

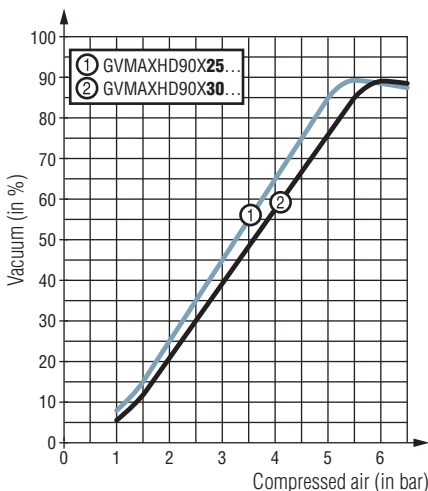

Suction Flow Rate/Compressed Air

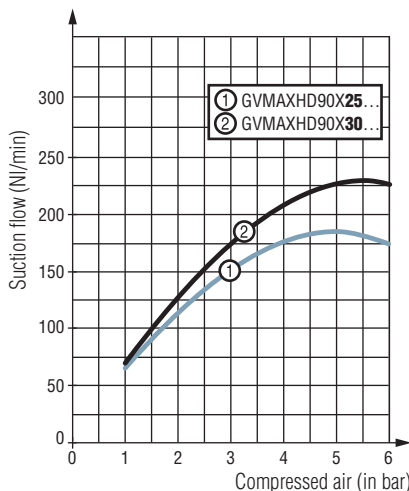

Suction Flow Rate/Vacuum

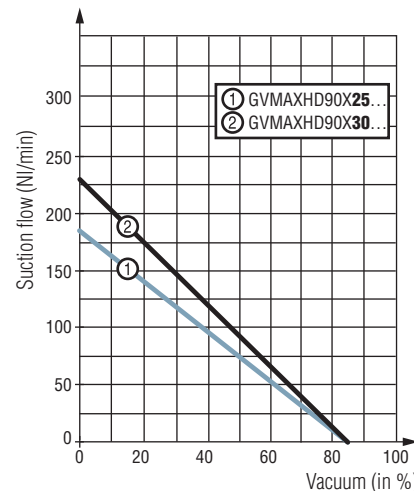

GVMAX HD

Heavy Duty Communicating Vacuum Pumps

Energy Savings and Smart Adaptation



Averages 90% energy savings

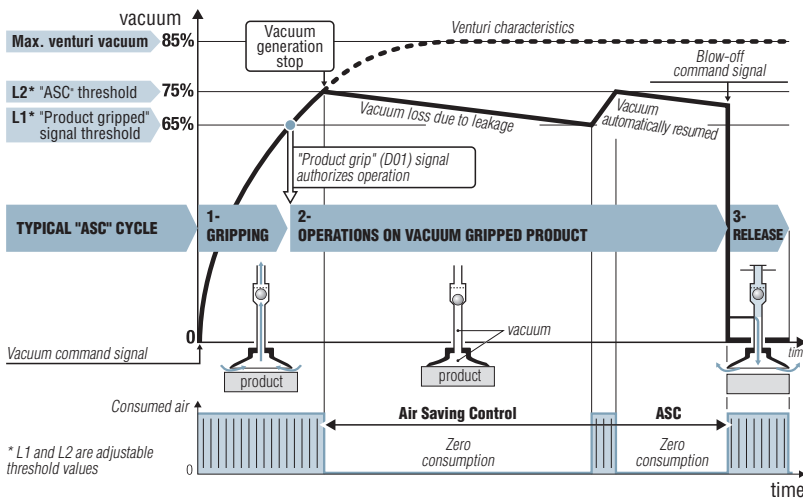

* L1 and L2 are adjustable threshold values

Air Saving Control (ASC) is a smart vacuum control system that stops the consumption of compressed air as soon as the required level of vacuum is reached, thus avoiding any unnecessary consumption and contributing to savings on the equipment's operating costs.

For airtight objects, the GVMAX HD vacuum pumps automatically execute the above "ASC" cycle, thus leading to maximal energy savings, according to the following 3 phases:

- 1- Object is gripped: vacuum generated by the Venturi pump
- 2- Operations on object held in place by vacuum: at the L2 vacuum threshold (75%), the supply of the Venturi pump is cut off → the consumption becomes zero; the object remains held in place owing to the non-return valve. If micro-leaks make the vacuum drop to threshold L2 less the defined hysteresis value, vacuum generation is briefly switched on again.
- 3- Object is released: by an external or an automatic timed blow-off command (according to the settings).

1- Gripping + transfer (nozzle dia. 2.5 mm, emptying 0.6 l)

Phase	Duration	Air consumption		Achieved economy
		w/o "ASC"	with "ASC"	
Gripping	0.50 s	2.42 NI	2.42 NI	Achieved economy
Transfer	2.00 s	9.67 NI	0	
Release	0.14 s	0.68 NI	0.68 NI	
		12.77 NI	3.10 NI	→ 76 %

2- Clamping + operations (nozzle dia. 2.5 mm, emptying 1 l)

Phase	Duration	Air consumption		Achieved economy
		w/o "ASC"	with "ASC"	
Clamping	0.83 s	4.01 NI	4.01 NI	Achieved economy
Operations	60 s	290 NI	0	
Release	0.14 s	0.68 NI	0.68 NI	
		294.69 NI	4.69 NI	→ 98 %

→ Resulting savings

"ASC" energy savings are major as shown in the 2 examples below:

- 76% savings when transferring an object after gripping
- 98% savings when clamping an object during an operation lasting 1 min

The investment generally pays off within just a few months.

ENERGY SAVING APP

Calculate the savings you can generate with our ASC technology using our ENERGY SAVING APP available online.



Smart adaptation

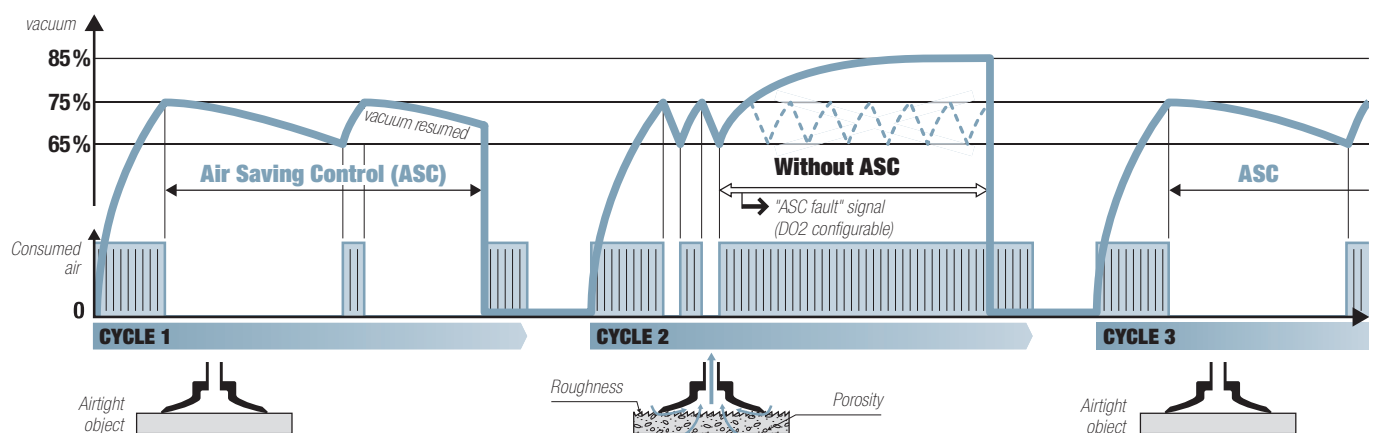

The above illustration shows the GVMAX HD's ability to adapt. "ASC" operation is automatic for any object that is adequately airtight (cycle 1). Should a leakage occur (cycle 2), due to a rough or porous object, or due to a leak in the vacuum network, the vacuum pump would automatically detect the unwanted condition,

complete the cycle without ASC in order to keep production running, and report the situation for possible maintenance. Production keeps running. As soon as everything returns to normal (cycle 3), operation with ASC is automatically restored.

GVMAX HD

Heavy Duty Communicating Vacuum Pumps Straightforward Communication



NFC)))

IO-Link
AIR Saving Control

Easier Integration, Use, and Diagnostics

The GVMAX HD heavy duty vacuum pump series include various features that enable setup, use, and diagnostics in all situations and at all levels (operators, process, networked factory), with the aim in mind of keeping the use and management of the pumps as straightforward as possible and thus allowing for their easy integration in your smart factory.

Advantages:

- Straightforward wiring and installation
- Remote configuration, control, and diagnostics
- Installation and diagnostic tools

Settings, Diagnostics, and Process Data



CONFIGURABLE SETTINGS

- Choice of language: EN, FR, DE, IT or ES
- "Object gripped" and ASC control thresholds
- ASC vacuum control system management
- Automatic blow-off
- Vacuum measurement unit: kPa, %, mbar, inHg
- Pressure measurement unit: MPa, bar, Psi
- Software updates, and more



DIAGNOSTICS

- Cycle counters (vacuum and blow-off control, objects gripped, objects lost, etc.)
- Vacuum network sizing support to prevent pressure loss
- Clogging detection function
- Supply pressure monitoring
- Supply voltage monitoring
- Software version
- Product item number and serial number



PROCESS INPUT DATA

- Vacuum and blow-off control



PROCESS OUTPUT DATA

- Instantaneous vacuum level
- Object gripped and object lost information
- ASC vacuum control system status
- Alarms (high/low pressure, high/low voltage)
- Instantaneous pressure

8 GVMAX HD

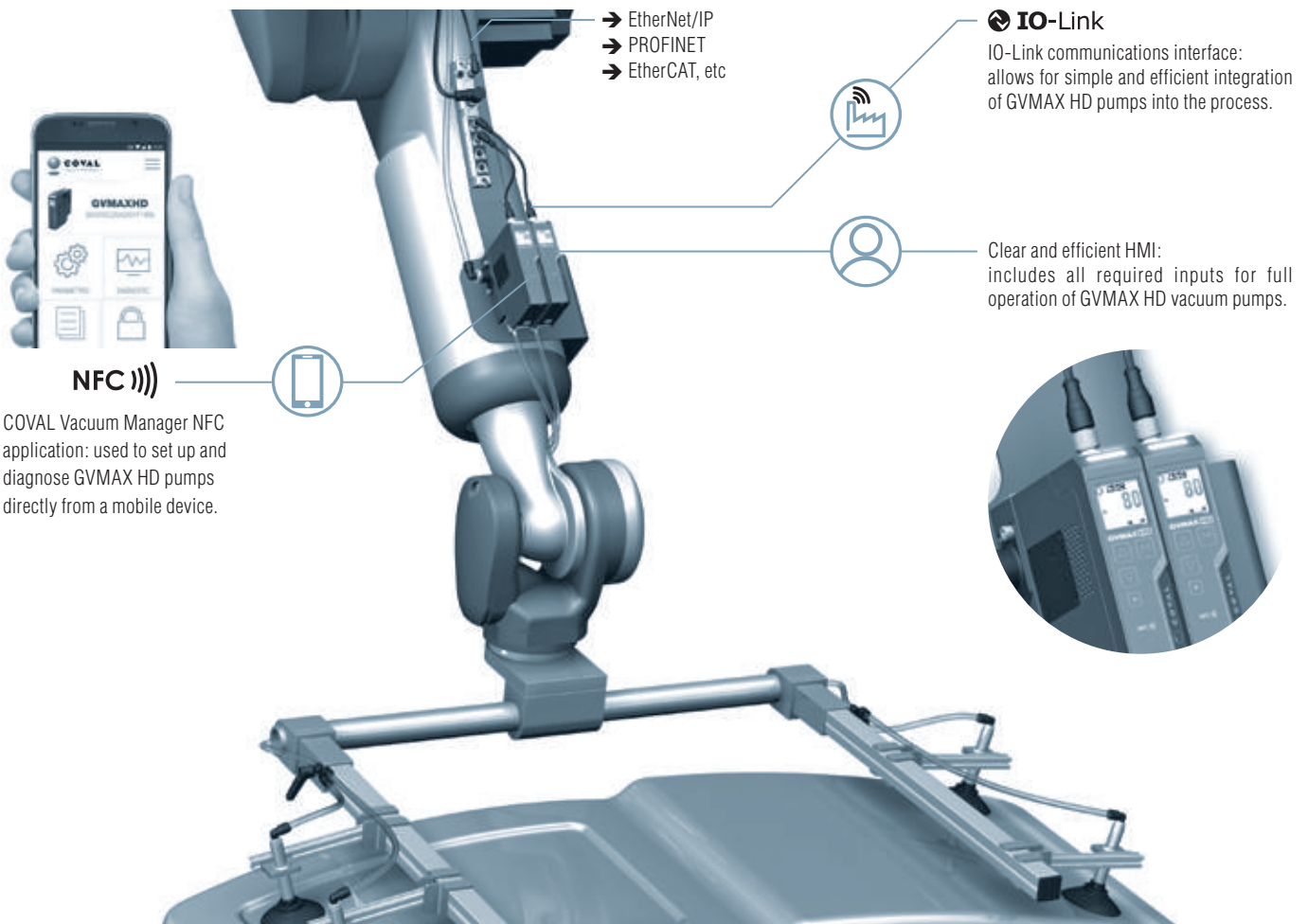

GVMAX HD

Heavy Duty Communicating Vacuum Pumps

Straightforward Communication



HMI

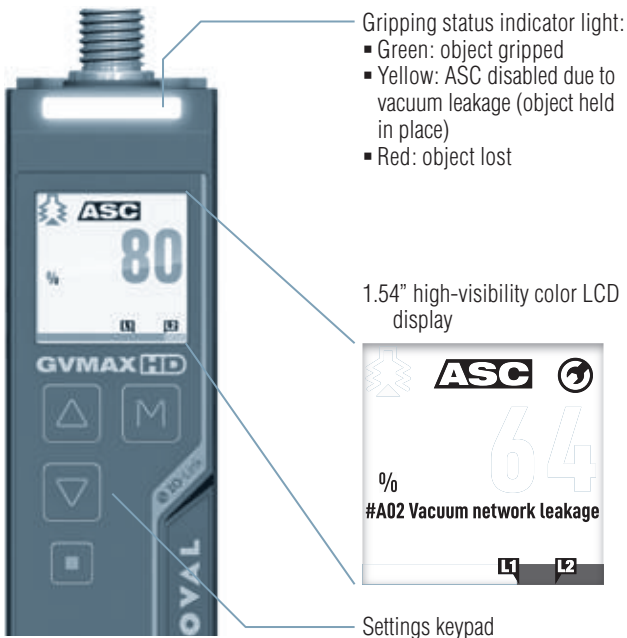

- Gripping status indicator light:
- Green: object gripped
 - Yellow: ASC disabled due to vacuum leakage (object held in place)
 - Red: object lost

1.54" high-visibility color LCD display

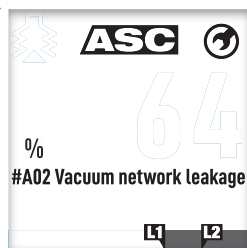

Settings keypad

The GVMAX HD HMI allows for easy and efficient reading of the pump's operation.

The high-visibility display includes all required inputs for full operation:

- Main information is easy to read
- Multilingual: EN - FR - DE - IT - ES
- Simple and clear event messages
- Intuitive settings and diagnostics menus
- Configurable display orientation: 0 – 90 – 180 – 270°
- Lockable to prevent undesired changes

Note: a version with remote HMI is available (see p. 8/57)

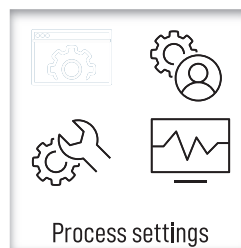

Process settings

Multilingual

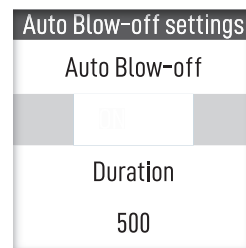

EN FR DE IT ES



IO-Link

The IO-Link system provides efficient real-time communication between GVMAX HD vacuum pumps and any higher-level protocol (EtherNet/IP, PROFINET, EtherCAT, etc.) required to monitor the production line. It can be used to control pumps, configure settings, and get feedback to ensure maximum productivity.

Advantages:

- Straightforward wiring, installation, and setup
- Availability of diagnostic status data
- Simpler preventive maintenance and vacuum pump replacement without manual setup, and more

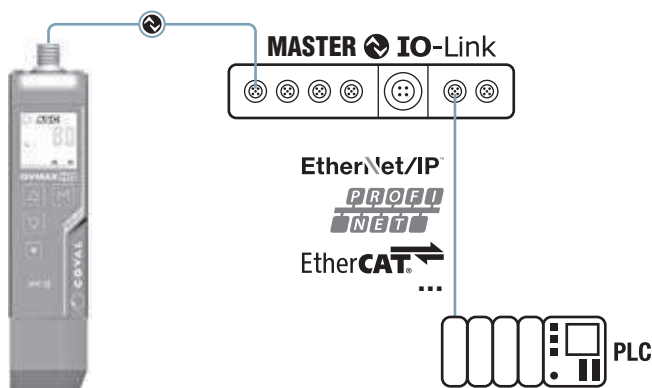

NFC

The NFC wireless technology integrated in GVMAX HD and in the COVAL Vacuum Manager application makes all setup and diagnostic functions available and modifiable on your mobile devices.

Additional features:

- Read/write settings with the power on or off
- Copy settings from one GVMAX HD to another
- Backup up to 5 setting configurations
- COVAL support: send a report including the settings and diagnostic data to COVAL for technical support



NFC App: COVAL Vacuum Manager
Available for Android and iOS

GVMAX HD

Heavy Duty Communicating Vacuum Pumps Configuration



NFC)))

IO-Link
AIR Saving Control

Available Configurations

VA version
(standalone)

GVMAX HD module screw-mounted onto its pneumatic socket



Versions with patented **SMART SWAP** system to quickly mount the GVMAX HD module onto its pneumatic socket

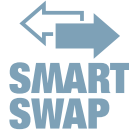

RA version
(standalone)

GVMAX HD standalone module with SMART SWAP system and pneumatic socket



RB version
(island)

Island of 3 GVMAX HD modules with SMART SWAP system on pneumatic sockets

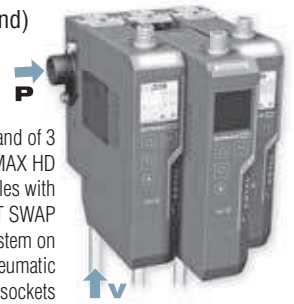

Remote HMI

To make it easier to use and set up vacuum pumps in certain use cases, the GVMAX HD range includes a version without a front dialog panel that can be used with a remote HMI.

Advantages:

- Place the HMI in an easily accessible and visible area
- Use one HMI for several GVMAX HD vacuum pumps
- Copy settings from one pump to another
- Use the GVMAX HD vacuum pump without any HMI connected

→ GVMAX HD vacuum pump without HMI

- Part No.: GVMAXHD **C25A5**
- Two M12 5-pin connectors
 - M12 blanking plug provided for use without HMI

→ Remote HMI

Part No.: **HMIHD1M84P**

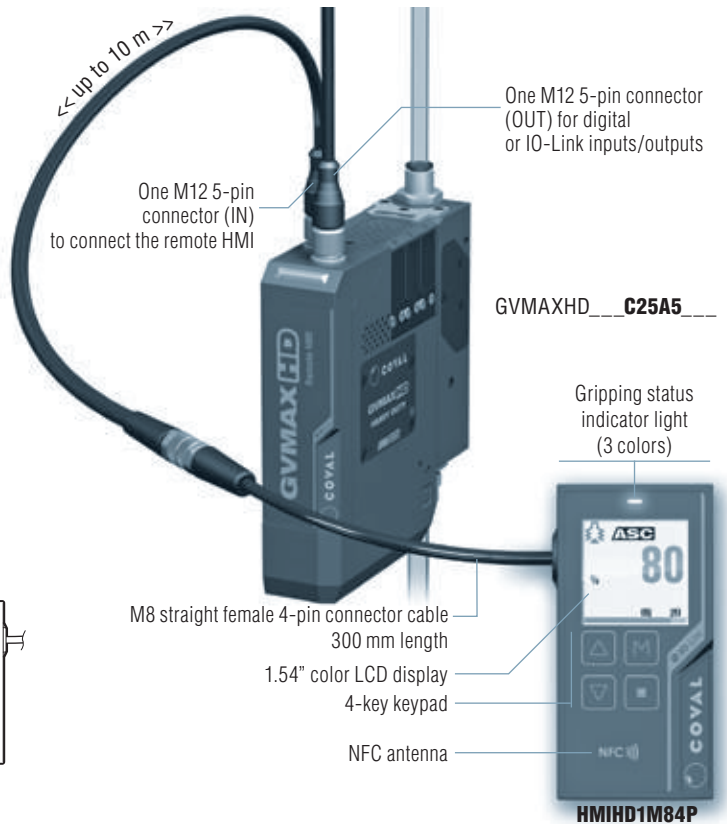
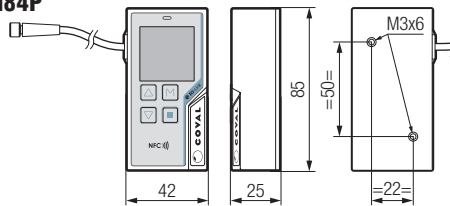

GVMAX HD 8

Accessories for remote HMI

Front mounting plate

- + 2 x M3x6 TORX
 - + 2 x M5x50 CHC
- Part No.: **HMIHD1FIXA**

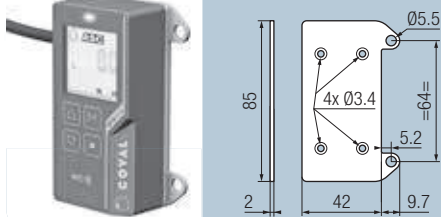

90° angled mounting plate

- + 2 x M3x6 TORX
- Part No.: **HMIHD1FIXB**

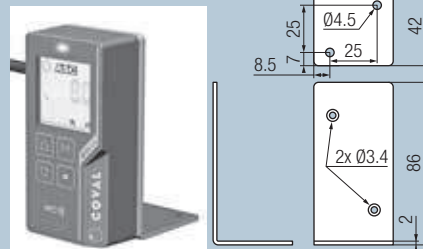

Connector cable

- M12 4-pin, female / M8 4-pin, male
- 2 m length: Part No. **CDM8MM12F4PL2**
 - 5 m length: Part No. **CDM8MM12F4PL5**
 - Other lengths available upon request.



GVMAX HD

Heavy Duty Communicating Vacuum Pumps

Modularity and Maintenance



SMART SWAP Quick-Mounting System

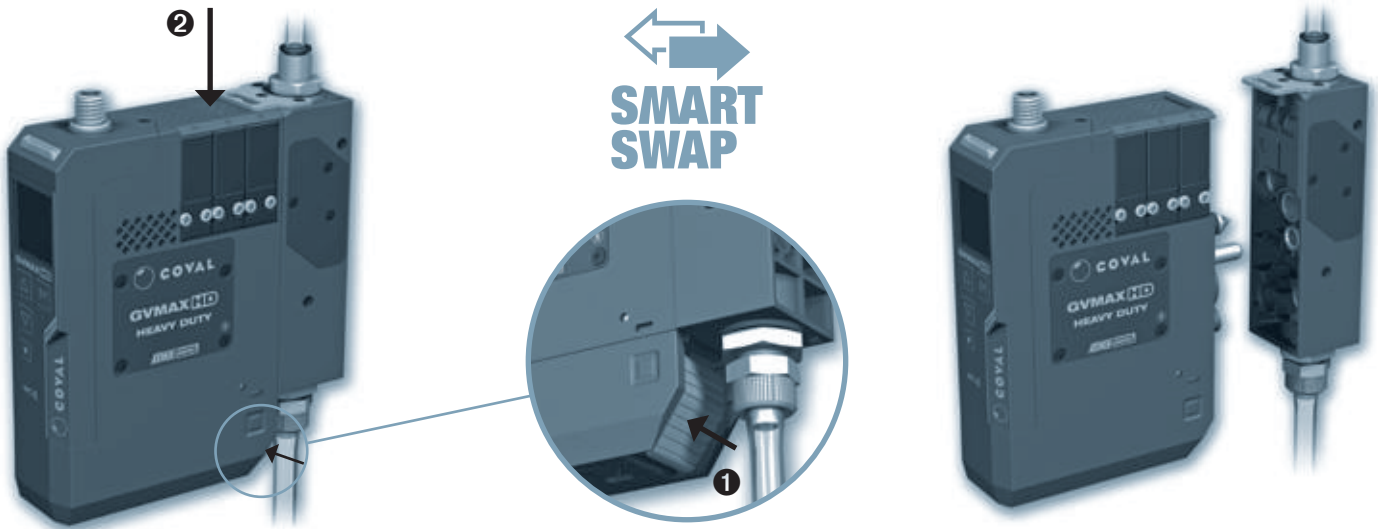

COVAL's patented SMART SWAP quick-mounting system allows you to mount the GVMAX HD module onto its pneumatic socket or remove it in the blink of an eye, without needing to disconnect compressed air and vacuum tubes.

No tools required, just two steps by operator to release: press release tab **1** at back of silencer and apply pressure to upper housing **2** of GVMAX HD.

- There is a locking screw on the release tab, which can be tightened to require operators to use a screwdriver to remove the module.
- Removal under pressure is made possible by the integrated non-return valve.



Modularity/Maintenance

The GVMAX HD vacuum pumps have been designed to withstand the demands from all your applications and to guarantee a high level of performance. However, handling certain objects may require replacement or cleaning.

The modular design of the GVMAX HD pumps ensures easy maintenance as the functions are all easily accessible.

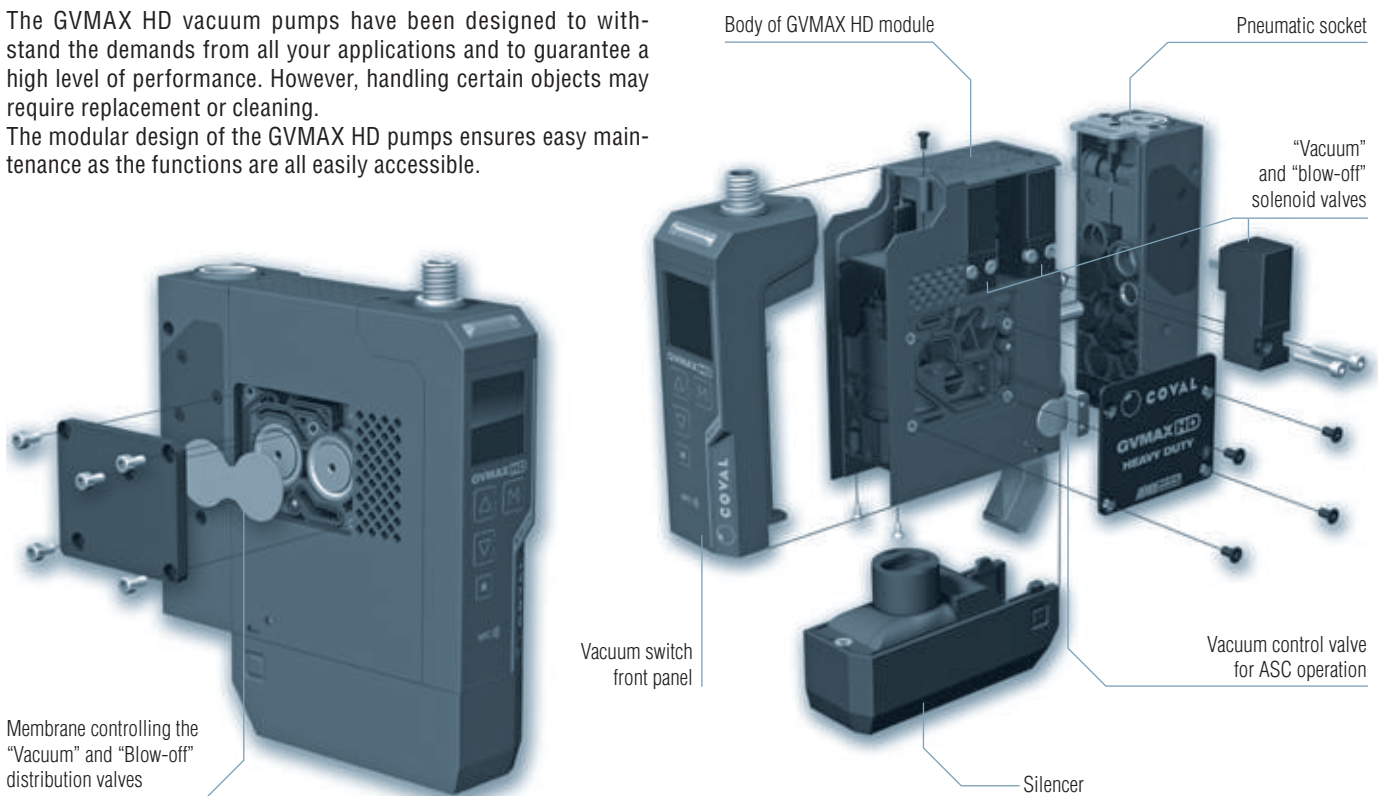

GVMAX HD

Heavy Duty Communicating Vacuum Pumps

Selection guide



Vacuum Control: 3 Solutions

Model GVMAXHD__S: vacuum pump with **NC** vacuum control and **NC** blow-off
In the event of power failure, vacuum is no longer generated. In the event of compressed air failure, the vacuum is no longer maintained.

- NC blow-off and vacuum control: solenoid valves
- Choice of blow-off settings:
 - Controlled by external signal
 - Automatic timer from 50 to 9999 ms (advantage: saves one controller output)

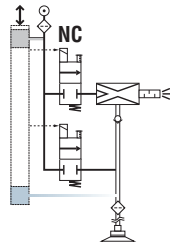

Model GVMAXHD__L: vacuum pump with **pulse-triggered bistable** vacuum control and **NC** blow-off (patented system)

In the event of power failure, the vacuum pump maintains its previous state. More specifically, one of the following two scenarios will take place should the failure occur:

- During vacuum generation, the vacuum is maintained → fail-safe
 - During blow-off or when the pump is off, the pump remains "Off"
- Vacuum control is automatically stopped when the blow-off command is activated. The vacuum can only be stopped with the blow-off command.

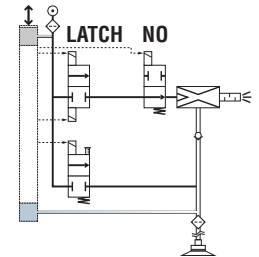

Model GVMAXHD__V: vacuum pump with **NO** vacuum control and **NC** blow-off

In the event of power failure, vacuum is still generated: object is held in place → fail-safe.

In the event of compressed air failure, the vacuum is no longer maintained.

- NO vacuum control solenoid valve
- NC blow-off control solenoid valve
- Blow-off controlled by external signal

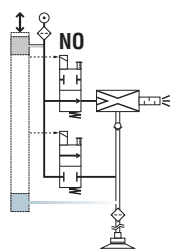

In the event of compressed air failure, the vacuum is no longer maintained.

- Pulse-triggered bistable vacuum control solenoid valve (50 ms min.)
- NC blow-off control solenoid valve
- Blow-off controlled by external signal

Electrical Connections

■ **C15A1:** One M12 5-pin male connector

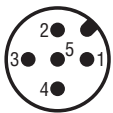

- 1 24 V DC
- 2 24 V DC suction command ⁽¹⁾
- 3 0 V - GND
- 4 24 V DC object gripped DO1 - C/Q
- 5 24 V DC blow-off command

■ **C18A1:** One M12 8-pin male connector



- 1 24 V DC object gripped DO1
- 2 24 V DC
- 3 /
- 4 24 V DC suction command ⁽¹⁾
- 5 24 V DC ASC Status DO2 - C/Q ⁽²⁾
- 6 24 V DC blow-off command
- 7 0 V - GND
- 8 /

■ **C24A2:** Two M12 4-pin male connectors

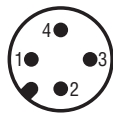

Rear connector:
IN

- 1 /
- 2 24 V DC blow-off command
- 3 0 V - GND
- 4 24 V DC suction command ⁽¹⁾

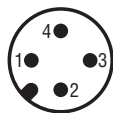

Front connector:
OUT

- 1 24 V DC
 - 2 24 V DC ASC Status DO2 ⁽²⁾
 - 3 0 V - GND
 - 4 24 V DC object gripped DO1 - C/Q
- Note: The Digital Outputs 1 and 2 signals can be swapped in the parameter settings.

Version for use with remote HMI

■ **C25A5:** Two M12 5-pin male connectors

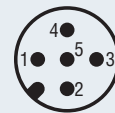

Rear connector:
IN

- 1 24 V DC
- 2 RS485 +
- 3 0 V - GND
- 4 RS485 -
- 5 /

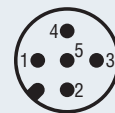

Front connector:
OUT

- 1 24 V DC
- 2 24 V DC suction command ⁽¹⁾
- 3 0 V - GND
- 4 24 V DC object gripped DO1 - C/Q
- 5 24 V DC blow-off command

⊗ : Connections for IO-Link

⁽¹⁾ 24 V DC suction command, depending on version:

- S: 24 V DC vacuum control
- V: 24 V DC vacuum off command
- L: 24 V DC vacuum control with min. pulse-triggering of 50 ms

⁽²⁾ DO2 configurable:

- ASC status (default)
- or Pressure fault (below 5 bar or above 8 bar)
- or Power supply fault (below 21.6 V or above 26.4 V)
- or ASC fault
- or Object lost

Accessories

Power supply cable: M12, straight, female – open end

- **CDM12N:** 4-pin, length. 2 m.
- **CDM12L5:** 4-pin, length. 5 m.
- **CDM125PL2:** 5-pin, length. 2 m.
- **CDM125PL5:** 5-pin, length. 5 m.



Power supply cable: M12, elbow, female – open end

- **CCM12:** 4-pin, length. 2 m.
- **CCM125PL2:** 5-pin, length. 2 m.



GVMAX HD

Heavy Duty Communicating Vacuum Pumps

Selection guide



Blow-off Function

There are 2 different versions of GVMAX HD vacuum pumps that feature different blow-off types to meet the requirements of any application:

■ **Standard blow-off (version GVMAXHD...F1)**

The blow-off flow is directed into the vacuum network and ensures the object is released in most applications.

■ **Powerful blow-off (version GVMAXHD...F2)**

This type of blow-off allows for objects to be quickly released in the event that the pump cannot be placed as close as possible to the suction cups, or to reduce the cycle time as much as possible.

The isolation valve **F** directs the entire blow-off flow towards the suction cups. In this case, the blow-off pressure is identical to the vacuum pump's compressed air supply pressure.

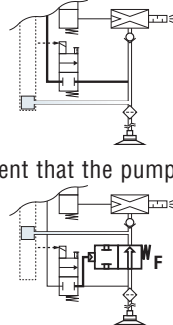

The blow-off control mode is configurable on GVMAX HD...**S** pumps:

- Controlled by external signal
- Automatic timer, adjustable from 50 to 9999 ms (advantage: saves one controller output)

On GVMAX HD...**V** and **L** pumps, the blow-off control mode is controlled by an external signal.

Standalone Vacuum Pumps or in Island Assemblies?

Standalone GVMAX HD vacuum pumps meet the needs of most common applications: a GVMAX HD controls one or several suction cups, which all operate according to the same sequence. Whenever several suction cups operate according to different sequences, several vacuum pumps are required. The choices are as follows:

- Several standalone pumps
- An island assembly including 1 to 4 vacuum pumps and a shared internal pressure supply

Standalone vacuum pumps are available in 2 versions:

- GVMAXHD...**VA**: pneumatic socket forms an integral part of the GVMAX HD module
- GVMAXHD...**RA**: patented SMART SWAP to quickly mount the GVMAX HD module on its pneumatic socket

GVMAXHD...RB1/2/3/4 mounted on an island: equipped as standard with the SMART SWAP system to quickly mount the GVMAX HD module on its pneumatic socket

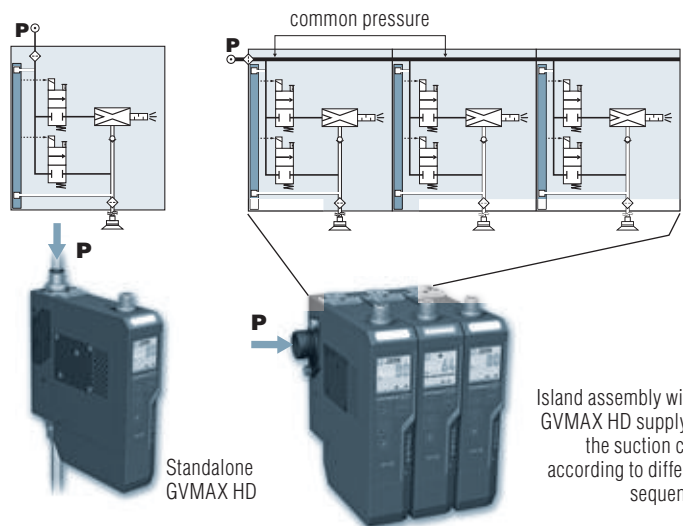

Island assembly with 3 GVMAX HD supplying the suction cups according to different sequences

Configuration of Island Assemblies

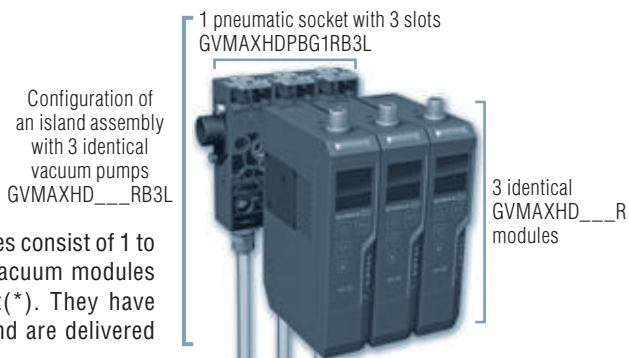

Standard island assemblies consist of 1 to 4 identical GVMAX HD vacuum modules and a pneumatic socket(*). They have specific part numbers and are delivered assembled.

For island assemblies consisting of different GVMAX HD vacuum modules, sub-assemblies must be ordered separately:

- Pneumatic socket in versions with 1, 2, 3, or 4 slots (*)
- GVMAX HD modules with SMART SWAP quick-mounting system (version R) depending on the selected configurations

Custom island assemblies are delivered unassembled.

(*) Assembled pneumatic sockets are supplied as standard with the pressure connection on the left side (version L). On request, an R version with right-hand pressure connection or a T version with top pressure connection is available.

Adding to an island assembly

A GVMAX HD vacuum pump can be added to an existing island assembly by ordering the pneumatic socket: for islands **GVMAXHDPBG1RB** and version **R** of the desired GVMAX HD module.

Reminder: 4 GVMAX HD/island

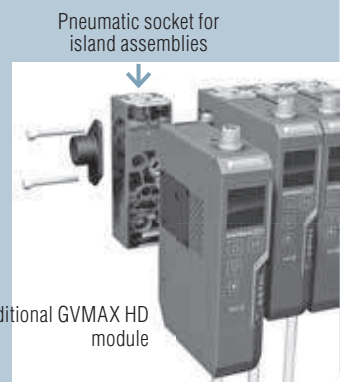

GVMAX HD

Heavy Duty Communicating Vacuum Pumps

Configuring a Vacuum Pump



GVMAXHD90X 25 L C15A1 X G1 F1 D RB3L

NOZZLE DIA.	
2.5 mm dia	25
3.0 mm dia	30

BLOW-OFF	
Standard blow-off	F1
Powerful blow-off <i>The powerful blow-off option is used when the object needs to be released quickly.</i>	F2

CONFIGURATIONS

Standalone vacuum pumps

VA	GVMAXHD90X __XG1_D_VA GVMAX HD module screwed onto its pneumatic socket	
RA	GVMAXHD90X __XG1_D_RA Standalone GVMAX HD module with SMART SWAP quick-mounting system and pneumatic socket	

Vacuum pumps mounted on an island (with SMART SWAP quick-mounting system)

RB1L *	GVMAXHD90X __XG1_D_RB1L 1 x GVMAX HD module with SMART SWAP quick-mounting system and pneumatic socket with 1 slot ▪ Left lateral pressure connection	
RB2L *	GVMAXHD90X __XG1_D_RB2L Island consisting of 2 GVMAX HD modules with SMART SWAP quick-mounting system and pneumatic socket with 2 slots ▪ Common pressure supply ▪ Left lateral pressure connection	
RB3L *	GVMAXHD90X __XG1_D_RB3L Island consisting of 3 GVMAX HD modules with SMART SWAP quick-mounting system and pneumatic socket with 3 slots ▪ Common pressure supply ▪ Left lateral pressure connection	
RB4L *	GVMAXHD90X __XG1_D_RB4L Island consisting of 4 GVMAX HD modules with SMART SWAP quick-mounting system and pneumatic socket with 4 slots ▪ Common pressure supply ▪ Left lateral pressure connection	

GENERATOR CONTROL

Vacuum pump with NC vacuum control and NC blow-off Choice of blow-off settings: ▪ Controlled by external signal ▪ Automatic timer from 50 to 9999 ms (advantage: saves one controller output)	S
Vacuum pump with NO vacuum control and NC blow-off ▪ Blow-off controlled by external signal	V
Vacuum pump with pulse-triggered bistable vacuum control and NC blow-off ▪ Blow-off controlled by external signal	L

CONNECTOR(S)

C15A1	1 x M12 5-pin male
C18A1	1 x M12 8-pin male
C24A2	2 x M12 4-pin male
C25A5	2 x M12 5-pin male For use with remote HMI

Sample Part number consisting of a standalone vacuum pump:

GVMAXHD90X30VC24A2XG1F1DVA

Standalone GVMAX HD module screw-mounted onto a pneumatic socket, max. vacuum 85%, 3.0 mm nozzle, controlled by an NO vacuum solenoid valve, 2 M12 4-pin connectors, with standard blow-off.

Sample Part number consisting of an island:

GVMAXHD90X25LC18A1XG1F2DRB3L

Island assembly consisting of 3 GVMAX HD modules with SMART SWAP quick-mounting system and 1 pneumatic socket with 3 slots, left lateral pressure connection, max. vacuum 85%, 2.5 mm nozzle, pulse-triggered bistable vacuum control, 1 M12 8-pin connector, with powerful blow-off.

* On request, an **RB_R** version with right-hand pressure connection or a **RB_T** version with top pressure connection is available.

Mounting accessories for GVMAX HD

- **GVMAXHDFIXA**: front panel installation kit (1 plate + 4 fastening screws)
- **GVMAXHDFIXB**: DIN rail installation kit (1 clip + 2 fastening screws)

Remote HMI

Only to be used with GVMAXHD __C25A5__

- **Part No. HMIHD1M84P**

With M8 4-pin female connector cable, 0.3 m length



Accessories for remote HMI

- Front mounting plate: Part No. **HMIHD1FIXA**
- 90° angled mounting plate: Part No. **HMIHD1FIXB**
- M12 4-pin female / M8 4-pin male connector cable
 - 2 m length: Part No. **CDM8MM12F4PL2**
 - 5 m length: Part No. **CDM8MM12F4PL5**
 - Other lengths available upon request.

GVMAX HD

Heavy Duty Communicating Vacuum Pumps

Build your own island assembly



To build a custom island assembly containing different GVMAX HD vacuum modules, you need to order the parts below separately:

Note: Custom island assemblies come unassembled.

1 Select the Pneumatic Socket

GVMAXHDPBG1RB_L sockets come assembled with the corresponding set of end pieces and the pressure connection on the left side.



GVMAXHDPBG1RB1L*
Pneumatic socket with 1 slot



GVMAXHDPBG1RB2L*
Pneumatic socket with 2 slots



GVMAXHDPBG1RB3L*
Pneumatic socket with 3 slots



GVMAXHDPBG1RB4L*
Pneumatic socket with 4 slots

* On request, an R version with right-hand pressure connection or a T version with top pressure connection is available.

2 Select the GVMAX HD Modules (1 module for each slot in the socket)



GVMAXHD90X 25 L C15A1 X G1 F1 D R

NOZZLE DIA.		CONNECTOR(S)	BLOW-OFF
2.5 mm dia	25	C15A1 1 x M12 5-pin male	F1 Standard blow-off
3.0 mm dia	30	C18A1 1 x M12 8-pin male	F2 Powerful blow-off The powerful blow-off option is used when the object needs to be released quickly.
		C24A2 2 x M12 4-pin male	
		C25A5 2 x M12 5-pin male For use with remote HMI	



GENERATOR CONTROL

Vacuum pump with **NC** vacuum control and **NC** blow-off
Choice of blow-off settings:

- Controlled by external signal
- Automatic timed from 50 to 9999 ms (advantage: saves one controller output)

S

Vacuum pump with **NO** vacuum control and **NC** blow-off

- Blow-off controlled by external signal

V

Vacuum pump with **pulse-triggered bistable** vacuum control and **NC** blow-off

- Blow-off controlled by external signal

L

Example of a custom island assembly:

- 1 X **GVMAXHDPBG1RB3** → 1 pneumatic socket with 3 slots and SMART SWAP quick-mounting system
- 1 X **GVMAXHD90X25SC18A1XG1F1DR**
- 1 X **GVMAXHD90X30VC18A1XG1F2DR**
- 1 X **GVMAXHD90X25LC15A1XG1F1DR** } 3 GVMAX HD modules of different types for island assembly

Accessories for island assemblies

Part No. **GVMAXHDPBG1RB**



Single-slot pneumatic socket with SMART SWAP quick-mounting system to add a GVMAX HD vacuum pump to an existing island assembly.

Part No. **80005594**



Complete set of island assembly end pieces (version R) containing the following items:

- Right flange with G1/2"-F pressure connection + 350 µm filter screen.
- Left sealing flange.
- Flange fastening screws.

Part No. **80005413**



Complete set of island assembly end pieces (version L) containing the following items:

- Left flange with G1/2"-F pressure connection + 350 µm filter screen.
- Right sealing flange.
- Flange fastening screws.

Part No. **80005960**



Complete set of island assembly end pieces (version T), containing the following items:

- 2 sealing flanges.
- Flange fastening screws.

GVMAX HD

Heavy Duty Communicating Vacuum Pumps

Dimensions and Installation Options



NFC)))
IO-Link
AIR Saving Control

Note: All dimensions are in mm.

Lateral installation (standalone version)

2 x 5.3 mm dia. (for two Ø 5 mm through screws or bolts with large washers).

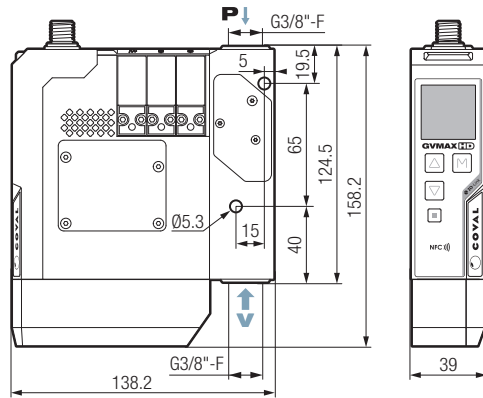

You can access 3D files of all our products in formats compatible with the main CAD software on our website
www.coval.com



Front Panel Installation

MOUNTING FROM REAR

4 x M5 screw threads, depth 8 mm

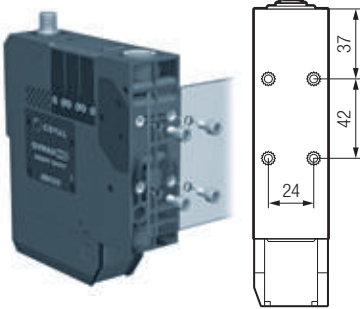

MOUNTING FROM FRONT

2 x 5.5 mm dia. (for M5 screw)

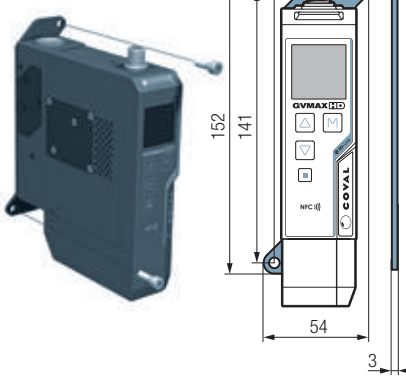

For front panel installation, order the following installation kit:

Part No.: **GVMAXHDFIXA**
 (1 plate + 4 fastening screws)

Installation on DIN Rail

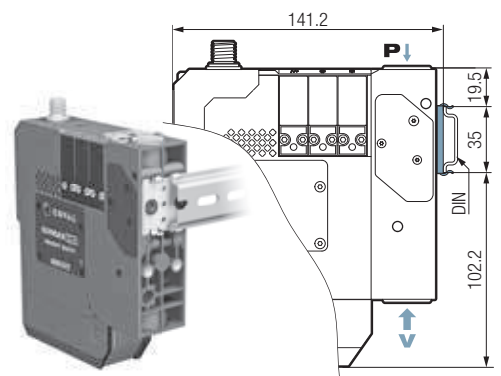

The pump can be mounted on a DIN rail for a static installation (e.g. in a cabinet). In this case, it must be equipped with an installation clip that is to be ordered separately:

Part No.: **GVMAXHDFIXB**
 (1 clip + 2 fastening screws) Note: For an island assembly, you need to order 2 installation kits.

8 GVMAX HD

Front Panel Installation for Modules with SMART SWAP Quick-mounting System

STANDALONE VERSION

2 x 5.5 mm dia. (for M5 screws) from inside the socket

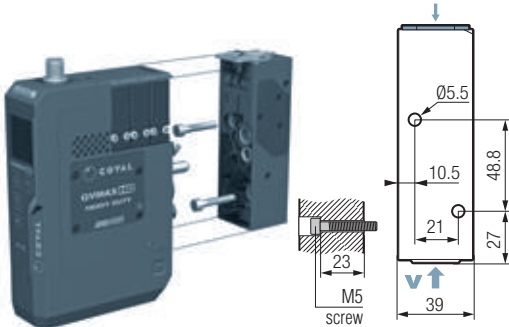

ISLAND VERSION

2 x 5.5 mm dia. (for M5 screws) from inside the socket

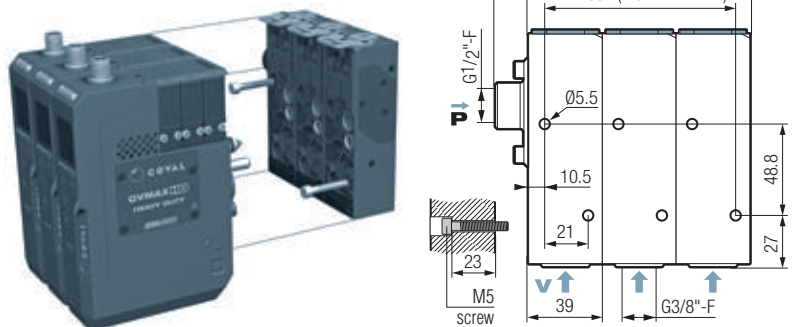

GVMAX HD

Heavy Duty Communicating Vacuum Pumps

Technical specifications



NFC)))

IO-Link
AIR Saving Control

- Supply: non-lubricated air, filtered to 5 microns, according to standard ISO 8573-1:2010 [3:4:4]
- Operating pressure: from 2 to 8 bar
- Optimal dynamic pressure:
 - 5 bar for dia. 2.5 mm nozzle
 - 5.5 bar for dia. 3.0 mm nozzle
- Powerful blow-off (option F2): network pressure
- Pressure connection:
 - Standalone vacuum pump: G3/8"-F with removable 350 µm filter screen
 - Island assembly: G1/2"-F with 350 µm filter screen
- Vacuum connection: G3/8"-F with removable 350 µm filter screen
- Max. vacuum: 85%
- Air suction flow rate: 185 / 230 NI/min
- Air consumption: 294 / 380 NI/min, when operating "without ASC"
- Integrated non-clogging silencer
- Noise level: approx. 71 dBA "without ASC" 0 dBA with ASC
- Degree of protection: IP65
- Max. operating frequency: 4 Hz
- Endurance: 50 million cycles
- Weight: 870 g
- Operating temperature: from 0 to 50 °C
- Materials: PA GF, brass, aluminum, steel, NBR, PU, FKM
- M12 male connectors

Analysis of ASC vacuum control system

- Permanent monitoring of leakage level: abort or automatically return to ASC operation

Integrated electronics

- 24 V DC power supply (regulated ±10 %)
- Vacuum measuring range: 0 to 99 %
- Pressure measuring range: 0 to 10 bar
- Vacuum and pressure measurement accuracy: ±1.5% of the range, compensated for temperature
- Inputs/outputs protected against reversed wiring and polarity
- Consumption: 170 mA max. (without load)
- Configurable input/output switching mode: PNP or NPN
- IO-Link or SIO (Standard Inputs Outputs) operation

DO1/DO2 output signals

- Configurable as PNP or NPN
- NO or NC
- Breaking capacity: 330 mA
- DO2 configurable (see Parameter settings)

Diagnostics

- Instantaneous vacuum level (unit transmitted over IO-Link: mbar)
- Available information: Object gripped, object lost, control in progress, and control fault
- Cycle counters (vacuum, blow-off, object gripped, object lost, ASC, etc.)
- Vacuum network sizing support to prevent head losses
- Clogging detection function
- Supply pressure monitoring
- Supply voltage monitoring
- Product item number and serial number
- Software version

Information displayed

- LED gripping status indicator on front panel (green: object gripped ; yellow: ASC disabled due to vacuum leakage (object held in place) ; red: object lost)
- 1.54" high-visibility color LCD display:
 - Displays vacuum level with bar graph and thresholds
 - Warns when service life has been exceeded (> 50 million cycles)
 - Explicit fault messages
 - "Suction cup" icon indicating the control status of control functions:
 - Green suction cup: vacuum control
 - Orange suction cup: blow-off control
 - Red suction cup: simultaneous vacuum and blow-off controls
 - Configurable display orientation: 0 – 90 – 180 – 270°

Parameter settings

- Performed with 4-key membrane keyboard
- Choice of language: EN, FR, DE, IT, or ES
- Choice of blow-off type:
 - Controlled
 - Automatic timed, adjustable from 50 to 9999 ms
- Choice of vacuum measurement unit (kPa, %, mbar, inHg)
- Choice of pressure measurement unit (MPa, bar, Psi)
- Monostable electrical manual controls
- Object gripped (L1) and L2 control thresholds
- Whenever required by the application, specific threshold and hysteresis settings that are different from the initial factory settings can be defined: L1=65%, h1=10%, L2=75%, h2=10%
- DO2 configurable (24 V DC) (only on C18A1 et C24A2 models):
 - ASC status (default)
 - or Pressure fault (below 5 bar or above 8 bar)
 - or Power supply fault (below 21.6 V or above 26.4 V)
 - or ASC fault
 - or Object lost
- Activation/deactivation of the ASC control system
- Activation/deactivation of the leakage level monitoring system (DIAG ECO) + adjustment of monitoring parameters

Communication

IO-Link

- Revision: 1.1
- Transmission rate: COM3 - 230.4 kbit/s
- Min. cycle time: 1 ms
- SIO mode: Yes
- Process Data Input (PDI): 6 bytes
- Process Data Output (PDO): 1 byte
- IO device description file (IODD) available for download

NFC

- COVAL VACUUM MANAGER Mobile app available:
 - Android, version 8.1 and higher
 - iOS, version 13 and higher

CMS HD

Heavy Duty Multi-stage Vacuum Pumps

General Information



NFC))))

IO-Link

COVAL's **CMS HD** series of multi-stage Heavy Duty vacuum pumps for industry specific applications are the result of many years of listening to and getting feedback from manufacturers, integrators, and users in the food, packaging, and robotics industries.

The **CMS HD** multi-stage vacuum pumps meet their expectations in terms of power, robustness, ease of configuration and use, communication, and modularity, while remaining compact and light for a simplified integration in a smart factory.

Industry-specific applications



Advantages

- Robust: resistant to the harsh environments of production lines
- High performance: optimized multi-stage Venturi system that guarantees powerful suction flow rates and reduced compressed air consumption.
- Modular: configurable according to needs and easy maintenance.
- Communicating: efficient communication system for all use levels, clear and easy to read HMI, NFC technology for mobile use, and IO-Link communications interface for straightforward networking.

Main Specifications (depending on version)

- 80% vacuum
- 3 powerful suction flow rates:
 - CMSHD90X50__ → 700 NI/min
 - CMSHD90X100__ → 1100 NI/min
 - CMSHD90X150__ → 1600 NI/min
- With or without vacuum and blow-off control
- Vacuum control: NC, NO
- With or without vacuum switch
- Blow-off controlled or automatic timed
- 1 or 2 M12 connectors
- Digital inputs/outputs mode (SIO) / IO-Link
- 3 exhaust configurations
- Degree of protection: IP65
- PNP / NPN
- Supply pressure monitoring (pressure sensor)
- Supply voltage monitoring
- Vacuum network status analysis and monitoring with a network sizing tool to prevent pressure loss, as well as a clogging detection function
- Remote HMI option features the following:
 - High-visibility color LCD display with clear multi-lingual messages and straightforward settings menu
 - Easy set up made possible by NFC technology and COVAL Vacuum Manager mobile application

A Complete Range

For each application, a suitable CMS HD:

CMSHD__NVO

- without control



CMSHD__SVOC15P / VVOC15P

- with vacuum and blow-off control
- without vacuum switch
- one M12 5-pin connector
- Digital inputs/outputs mode
- visual indicators of vacuum and blow-off controls



CMSHD__SVX_ / VVX__

- with vacuum and blow-off control
- with vacuum switch, and pressure sensor
- M12 connectors available in 3 versions:
 - one 5 or 8-pin connector
 - or two 4-pin connectors
- Digital inputs/outputs (SIO) / IO-Link Mode



Accessory: remote HMI Part No.: HMIHD1M84P

Compatible with CMSHD__VX__

- 1.54" color LCD display
- 4-key keypad
- Can be moved up to 10 m
- NFC



CMS HD

Heavy Duty Multi-stage Vacuum Pumps

General Information



NFC)))

IO-Link

CMS HD, "tailor-made" solution

CMSHD__NVO__
Pressure connection
end plate



CMSHD__SVO / VVO__
Control valve block for
vacuum and blow-off
without vacuum switch

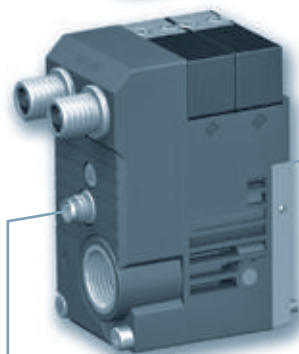
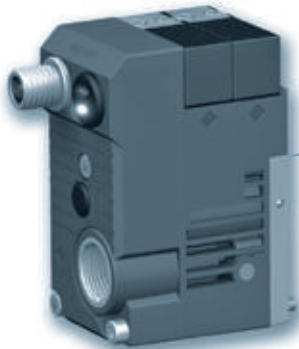

CMSHD__SVX / VVX__
Control valve block for vacuum
and blow-off with vacuum switch,
pressure sensor, compatible with
remote HMI



Remote HMI
Part No.: **HMIHD1M84P**

CMSHD90X50_ / CMSHD90X100_
Simple body



CMSHD90X150_
Double body



Different configurations
available for the exhaust:

CMSHD____K
Silencer

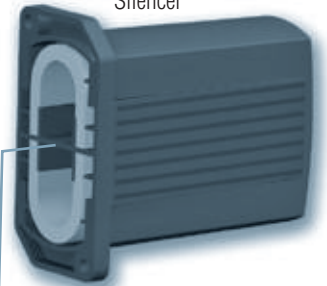

CMSHD____F
Diffuser



CMSHD____E
Collector exhaust



Note: Exhaust options are delivered
mounted in line. They can be mounted by
the user at 90° on the front panel of the
CMS HD.

CMS HD

Heavy Duty Multi-stage Vacuum Pumps

General Information



CMS HD with control and vacuum switch



Digital inputs/outputs (SIO) / IO-Link

M12 connectors available in 3 versions:

- one 5 or 8-pin connector
- or two 4-pin connectors



Onboard installation and diagnostic tools:

- Vacuum network sizing support and clogging detection
- Supply pressure and voltage monitoring

- NC, NO vacuum control
- Blow-off controlled or automatic timed

M8 connector for remote HMI

P
Pressure

V
Vacuum

E
Exhaust



Vacuum generation with multi-stage Venturi pump:

- high suction rates
- silent operation

8
CMS HD



Clear and efficient HMI: includes all required inputs for full operation of CMS HD multi-stage vacuum pumps.

Accessory: remote HMI
Part No.: HMIHD1M84P



Gripping status indicator light (2 colors)

1.54" high-visibility color LCD display with clear multilingual messages and straightforward settings menu

Settings keypad



NFC)))

Straightforward setup and diagnostics made possible by NFC technology and COVAL Vacuum Manager mobile application.

CMS HD

Heavy Duty Multi-stage Vacuum Pumps

Integration and Performance



NFC)))

IO-Link

Integrated Functions

CMS HD multi-stage vacuum pumps include all the "vacuum" functions required for an easy, efficient and economical use of compressed air and suitable for any application:

- ❶ "Vacuum" solenoid valve
- ❷ Multi-stage Venturi pump
- ❸ Through-type silencer
- ❹ Electronic vacuum switch
- ❺ Integrated electronics
- ❻ Pressure sensor
- ❼ "Blow-off" solenoid valve
- ❽ Removable filter screens

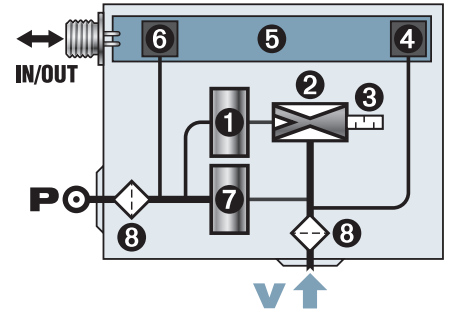

Primary Functions

Multi-stage technology consists of maximizing the energy input of the compressed air by cascading several stages of Venturi profiles and by combining their respective flows. Intermediate valves allow the progressive isolation of each stage to obtain a maximum vacuum level. This technology makes it possible to generate a high suction flow rate at a low vacuum level.

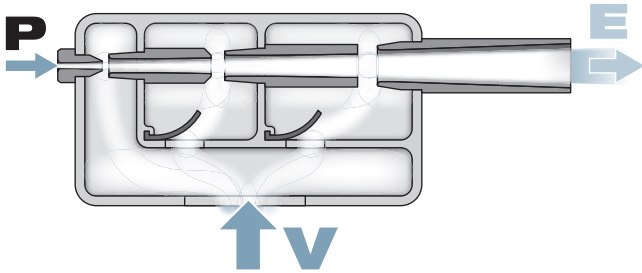

Performance Determined by CMS HD Model

Model	Max. vacuum (%)	Air drawn in (NI/min)	Air consumed (NI/min)	Air pressure level* (bar)
CMSHD90X50	80	700	220	5.5
CMSHD90X100	80	1100	420	5.5
CMSHD90X150	80	1600	620	5.5

* 6 bar for versions with control:

CMSHD90X50S_ / CMSHD90X50V_ / CMSHD90X100S_ / CMSHD90X100V_

* 6.5 bar for versions with control:

CMSHD90X150S_ / CMSHD90X150V_

- CMSHD90X50_ : 2 profiles 3 stages
- CMSHD90X100_ : 4 profiles 3 stages
- CMSHD90X150_ : 6 profiles 3 stages

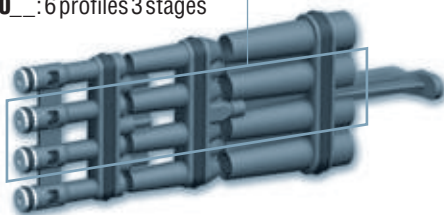

Vacuum / Compressed air

- ❶ / CMSHD90X50NVO
- ❷ / CMSHD90X50S_ / V_
- CMSHD90X100NVO
- ❸ / CMSHD90X100S_ / V_
- CMSHD90X150NVO
- ❹ / CMSHD90X150S_ / V_

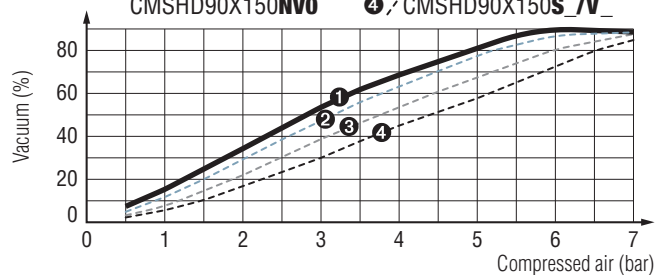

Suction flow / Compressed air

- ❶ / CMSHD90X50NVO
- ❷ / CMSHD90X100NVO
- ❸ / CMSHD90X150NVO
- ❹ / CMSHD90X50S_ / V_
- ❺ / CMSHD90X100S_ / V_
- ❻ / CMSHD90X150S_ / V_

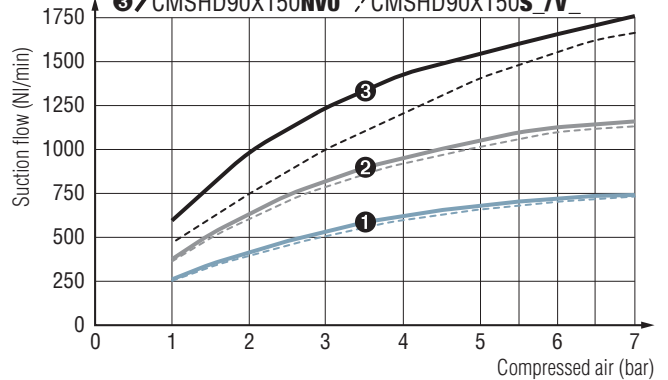

Suction Flow / Vacuum

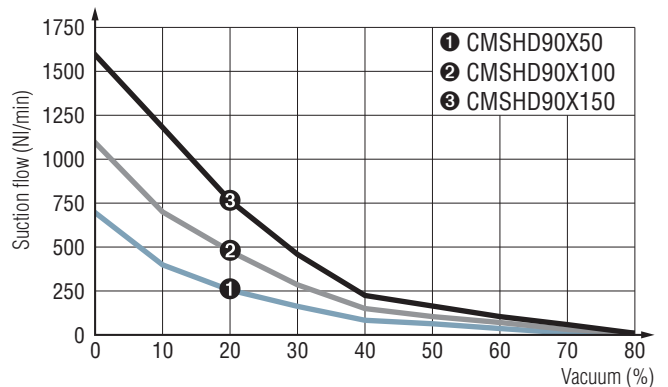

The values represent the average characteristics of our products.

8
CMS HD

CMS HD

Heavy Duty Multi-stage Vacuum Pumps

Straightforward Communication



NFC))))

IO-Link

Easier Integration, Use, and Diagnostics

The **CMSHD__VX** Heavy Duty multi-stage vacuum pump series includes various features that enable setup, use, and diagnostics in all situations and at all levels (operators, process, networked

factory), with the aim in mind of keeping the use and management of the pumps as straightforward as possible and thus allowing for their easy integration in your smart factory.

Settings, Diagnostics and Process Data



CONFIGURABLE SETTINGS

- Choice of language: EN, FR, DE, IT or ES
- "Object gripped" thresholds
- Automatic blow-off
- Vacuum measurement unit: kPa, %, mbar, inHg
- Pressure measurement unit: MPa, bar, psi
- Software updates, and more



DIAGNOSTICS

- Cycle counters (vacuum and blow-off control, objects gripped, objects lost, etc.)
- Vacuum network sizing support to prevent pressure loss
- Clogging detection function
- Supply pressure and voltage monitoring
- Software version
- Product part number and serial number



PROCESS INPUT DATA

- Vacuum and blow-off control



PROCESS OUTPUT DATA

- Instantaneous vacuum level
- Object gripped and object lost information
- Alarms (high/low pressure, high/low voltage)
- Instantaneous pressure

8



IO-Link

The IO-Link system provides efficient real-time communication between **CMSHD__VX_** multi-stage vacuum pumps and any higher-level protocol (EtherNet/IP, PROFINET, EtherCAT, etc.) required to monitor the production line. It can be used to control pumps, configure settings, and get feedback to ensure maximum productivity.

Advantages:

- Straightforward wiring, installation, and setup
- Availability of diagnostic status data
- Simpler preventive maintenance and vacuum pump replacement without manual setup, and more
- Onboard installation and diagnostic tools

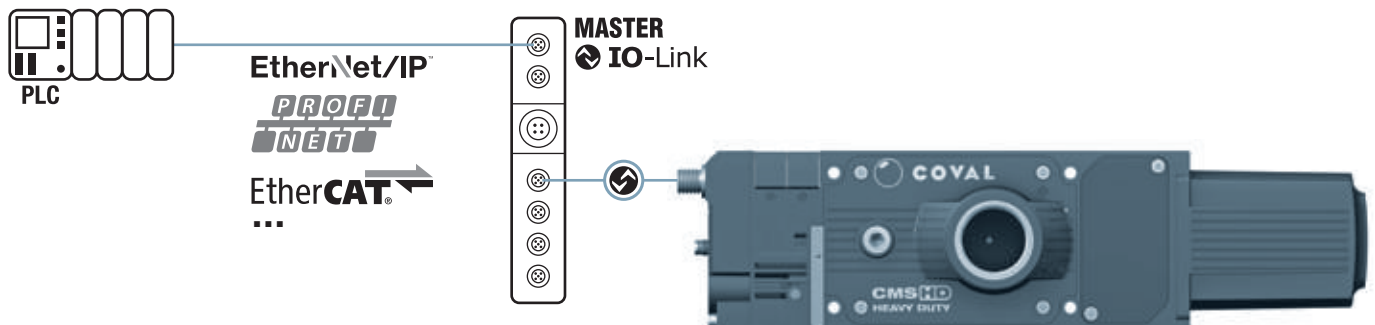

CMS HD

Heavy Duty Multi-stage Vacuum Pumps

Straightforward Communication



NFC)))

IO-Link

Remote HMI (accessory)

To make it easier to use and set up multi-stage piloted vacuum pumps, the CMS HD series has a remote HMI as an accessory.

Advantages:

- Place the HMI in an easily accessible and visible area
- Use one HMI for several CMS HD multi-stage vacuum pumps
- Copy settings from one pump to another
- Use the CMS HD multi-stage vacuum pump without any HMI connected

CMS HD multi-stage vacuum pumps compatible with the remote HMI:

→ CMSHD__VX__ versions with M8 connector (electrical connections: see p. 8/73)

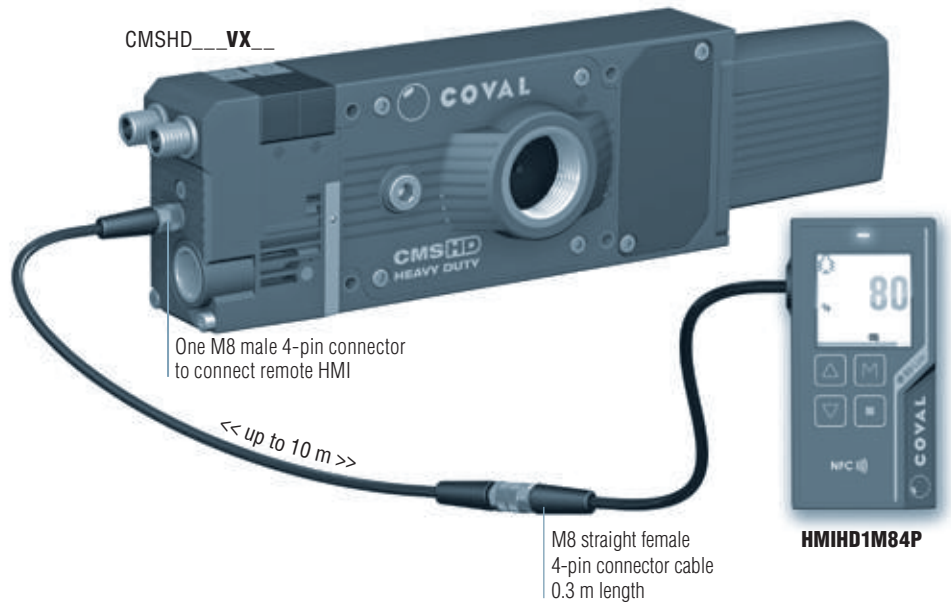

→ Remote HMI

Part No.: HMIHD1M84P

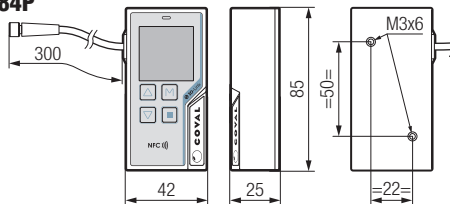

Remote HMI Dialog Front Panel

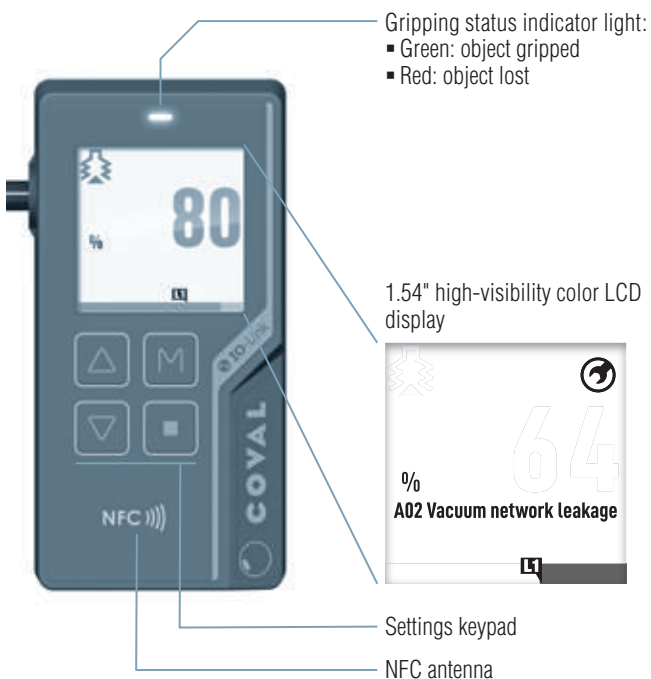

The remote HMI allows for easy and efficient reading of the pump's operation. The high-visibility display includes all required inputs for full operation:

- Main information is easy to read
- Multilingual: EN - FR - DE - IT - ES
- Simple and clear event messages
- Intuitive settings and diagnostics menus
- Configurable display orientation: 0 - 90 - 180 - 270°
- Lockable to prevent undesired changes

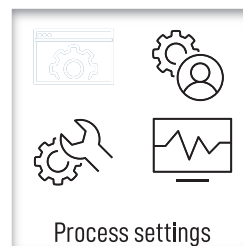

Multilingual

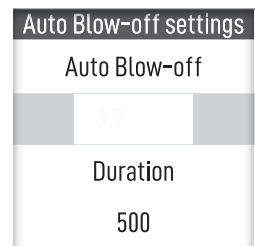

EN FR DE IT ES

CMS HD

Heavy Duty Multi-stage Vacuum Pumps

Straightforward Communication



NFC))))

IO-Link



NFC))))

The NFC wireless technology integrated in remote HMI and in the COVAL Vacuum Manager application makes all setup and diagnostic functions available and modifiable on your mobile devices.

Additional features:

- Read/write settings with the power on or off
- Copy settings from one CMS HD to another
- Backup up to 5 setting configurations
- COVAL support: send a report including the settings and diagnostic data to COVAL for technical support



NFC APP: COVAL Vacuum Manager
Available for Android and iOS



Accessories for remote HMI

Front mounting plate

- + 2 x M3x6 TORX
- + 2 x M5x50 CHC

Part No.: **HMIHD1FIXA**



Side mounting plate

- + 2 x M3x6 TORX
- + 2 x M5x50 CHC

Part No.: **HMIHD1FIXC**

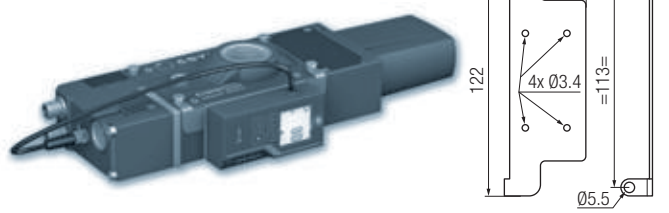

90° angled mounting plate

- + 2 x M3x6 TORX

Part No.: **HMIHD1FIXB**

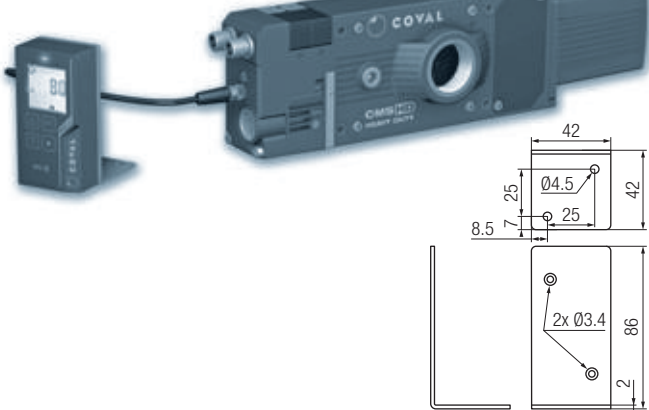

Connecting cable

M8 4-pin, female / M8 4-pin, male, compatible with cable chain

- 2 m length: Part No. **CDM8MF4PL2**
- 5 m length: Part No. **CDM8MF4PL5**
- Other lengths available upon request.



Note: all dimensions are in mm.

CMS HD 8

CMS HD

Heavy Duty Multi-stage Vacuum Pumps

Modularity and Maintenance



NFC)))

IO-Link

Choice of 3 equipment options for the exhaust

Various configuration options are available for the CMS HD exhaust:

Through-type silencer

CMSHD...K version

- reduction of the noise level (-10 dBA compared to a diffuser)
- non-clogging



Diffuser

CMSHD...F version

- ultra-compact



Exhaust collector

CMSHD...E version

- G1" female connection



The exhaust options are delivered in-line but, depending on the environment, they can be positioned by the user on the front panel.



Modularity/Maintenance

The CMS HD multi-stage vacuum pumps have been designed to withstand the demands from all your applications and to guarantee a high level of performance. However, handling certain parts may

require replacement or cleaning.

The modular design of the CMS HD multi-stage pumps ensures easy maintenance as the functions are all easily accessible.

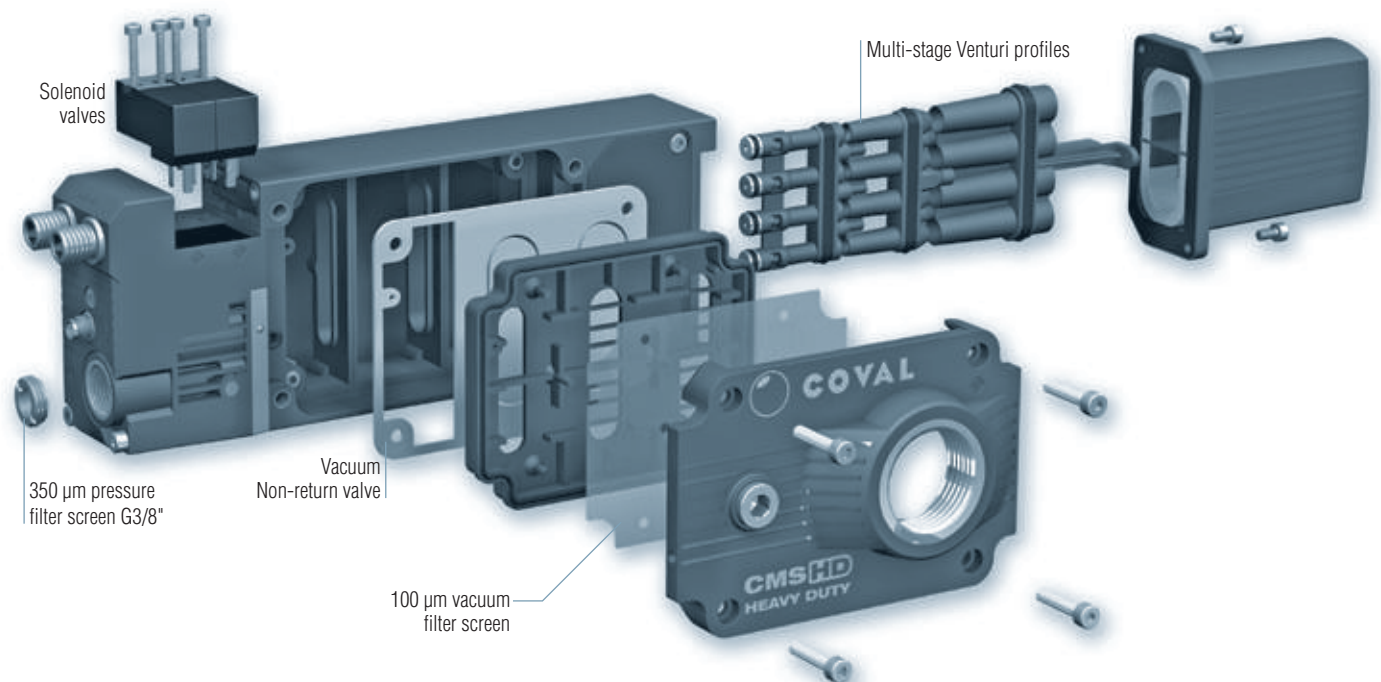

CMS HD

Heavy Duty Multi-stage Vacuum Pumps

Selection guide



NFC))))

IO-Link

Vacuum Control: 2 Solutions

Model CMSHD__S: vacuum pump with **NC** vacuum control and **NC** blow-off control. In the event of power failure, vacuum is no longer generated. In the event of compressed air failure, the vacuum is no longer maintained.

- NC blow-off and vacuum control: solenoid valves
- Choice of blow-off settings (only on CMSHD__SVX__models):
 - controlled by external signal
 - automatic timer from 50 to 9999 ms (advantage: saves one controller output)

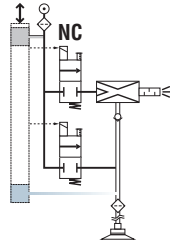

Model CMSHD__V: vacuum pump with **NO** vacuum control and **NC** blow-off control. In the event of power failure, vacuum is still generated: part is held in place → fail-safe.

In the event of compressed air failure, the vacuum is no longer maintained.

- NO vacuum control solenoid valve
- NC blow-off control solenoid valve
- Blow-off controlled by external signal

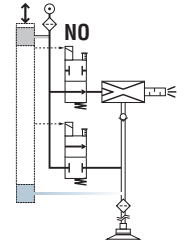

Electrical Connections

VOC15P:

- One M12 5-pin male connector

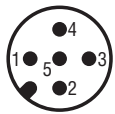

- | | |
|---|----------------------------------------|
| 1 | / |
| 2 | 24 V DC suction command ⁽¹⁾ |
| 3 | 0 V - GND |
| 4 | 24 V DC blow-off command |
| 5 | / |



VXC15X:

- One M12 5-pin male connector

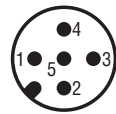

- | | |
|---|----------------------------------------|
| 1 | 24 V DC |
| 2 | 24 V DC suction command ⁽¹⁾ |
| 3 | 0 V - GND |
| 4 | 24 V DC object gripped DO1 - C/Q |
| 5 | 24 V DC blow-off command |



- One M8 4-pin male connector → remote HMI



- | | |
|---|---------------|
| 1 | 24 V DC |
| 2 | RS485 (DATA+) |
| 3 | 0 V - GND |
| 4 | RS485 (DATA-) |

VXC18X:

- One M12 8-pin male connector

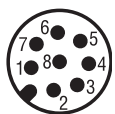

- | | |
|---|----------------------------------------------|
| 1 | 24 V DC object gripped DO1 |
| 2 | 24 V DC |
| 3 | / |
| 4 | 24 V DC suction command ⁽¹⁾ |
| 5 | 24 V DC object lost DO2 - C/Q ⁽²⁾ |
| 6 | 24 V DC blow-off command |
| 7 | 0 V - GND |
| 8 | / |



- One M8 4-pin male connector → remote HMI



- | | |
|---|---------------|
| 1 | 24 V DC |
| 2 | RS485 (DATA+) |
| 3 | 0 V - GND |
| 4 | RS485 (DATA-) |

VXC24X:

- Two M12 4-pin male connectors

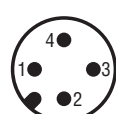

- | | |
|---|----------------------------------------|
| 1 | / |
| 2 | 24 V DC blow-off command |
| 3 | 0 V - GND |
| 4 | 24 V DC suction command ⁽¹⁾ |

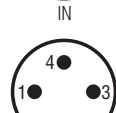

- | | |
|---|----------------------------------------|
| 1 | 24 V DC |
| 2 | 24 V DC object lost DO2 ⁽²⁾ |
| 3 | 0 V - GND |
| 4 | 24 V DC object gripped DO1 - C/Q |
| 5 | / |



- One M8 4-pin male connector → remote HMI



- | | |
|---|---------------|
| 1 | 24 V DC |
| 2 | RS485 (DATA+) |
| 3 | 0 V - GND |
| 4 | RS485 (DATA-) |

: connections for IO-Link

⁽¹⁾ 24 V DC suction command, depending on version:

- **S:** 24 V DC vacuum control
- **V:** 24 V DC vacuum off command

⁽²⁾ DO2 configurable:

- Object lost (default)
- or Power supply fault (below 21.6 V or above 26.4 V)
- or Pressure fault (below 5 bar or above 8 bar)

CMS HD

Heavy Duty Multi-stage Vacuum Pumps

Configuring a Vacuum Pump



NFC)))

IO-Link



CMS HD Without Control

CMSHD90X 100 N VO G4 K

SUCTION FLOW RATE	
700 NI/min	50
1100 NI/min	100
1600 NI/min	150

EXHAUST	
K	Through-type silencer
E	Exhaust collector
F	Diffuser

Sample part number consisting of a multi-stage vacuum pump without control:
CMSHD90X100NVOG4K

Multi-stage vacuum pump without control, max. vacuum 80%, suction flow rate 1100 NI/min with Through-type silencer

CMS HD With Control

CMSHD90X 100 S VX C15X G4 K D

SUCTION FLOW RATE	
700 NI/min	50
1100 NI/min	100
1600 NI/min	150

VACUUM SWITCH / HMI

Multi-stage vacuum pump without vacuum switch and HMI

- Simplified CMS HD with control, without settings and dialogs
- Digital inputs/outputs mode (SIO)

VO C15P

- One M12 5-pin male PNP



Multi-stage vacuum pump with integrated vacuum switch and pressure sensor, without HMI

- Electronic vacuum switch
- Digital Output DO1 "object gripped" 24 V DC / NO
- Digital input/outputs mode (SIO) / IO-Link
- Compatible with remote HMI

VX C15X

- One M12 5-pin male configurable as PNP or NPN
- One M8 4-pin male for remote HMI



IO-Link

C18X

- One M12 8-pin male configurable as PNP or NPN
- One M8 4-pin male for remote HMI
- Digital Output DO2 configurable 24 V DC / NO



IO-Link

C24X

- Two M12 4-pin male configurable as PNP or NPN
- One M8 4-pin male for remote HMI
- Digital Output DO2 configurable 24 V DC / NO



IO-Link

EXHAUST*

K	Through-type silencer
E	Exhaust collector
F	Diffuser

* Exhaust accessories are delivered mounted in line by default.

PRESSURE SENSOR

None on VO versions	-
Standard on VX versions	D

GENERATOR CONTROL

Vacuum pump with **NC** vacuum control and **NC** blow-off control. Choice of blow-off settings (only on CMSHD__SVX__models):

- Controlled by external signal
- Automatic timer from 50 to 9999 ms (advantage: saves one controller output).

S

Vacuum pump with **NO** vacuum control and **NC** blow-off control.

- Blow-off controlled by external signal

V

Sample part number consisting of a multi-stage vacuum pump with control:

CMSHD90X100SVXC15XG4FD

Multi-stage vacuum pump with control, max. vacuum 80%, suction flow rate 1100 NI/min, NC vacuum and blow-off control, one M12 5-pin connector and one M8 4-pin connector, with diffuser.

CMS HD

Heavy Duty Multi-stage Vacuum Pumps

Examples of Composed Part Numbers



NFC))))

IO-Link

CMSHD90X50NVOG4E

Multi-stage vacuum pump without control, max. vacuum 80%, suction flow rate 700 NI/min with exhaust collector.



CMSHD90X150NVOG4K

Multi-stage vacuum pump without control, max. vacuum 80%, suction flow rate 1600 NI/min with through-type silencer.

CMSHD90X100SVOC15PG4F

Multi-stage vacuum pump with control, max. vacuum 80%, suction flow rate 1100 NI/min, NC vacuum and blow-off control, one M12 5-pin connector, with diffuser.



CMSHD90X100VVC15XG4ED + HMIHD1M84P + HMIHD1FIXA

Multi-stage vacuum pump with control, max. vacuum 80%, suction flow rate 1100 NI/min, NO vacuum control and NC blow-off control, one M12 5-pin connector and one M8 4-pin connector, with exhaust collector + remote HMI and front mounting plate.

CMSHD90X150SVXC24XG4KD

Multi-stage vacuum pump with control, max. vacuum 80%, suction flow rate 1600 NI/min, NC vacuum and blow-off control, one M12 5-pin connector and one M8 4-pin connector, with through-type silencer.



8

CMS HD

CMS HD

Heavy Duty Multi-stage Vacuum Pumps

Dimensions



NFC))))

IO-Link

CMS HD Without Control

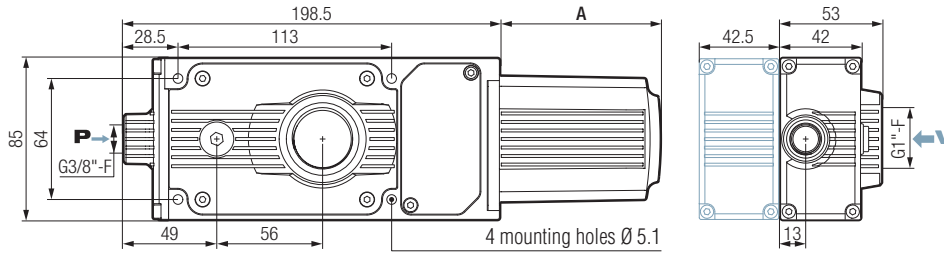

Note: all dimensions are in mm.

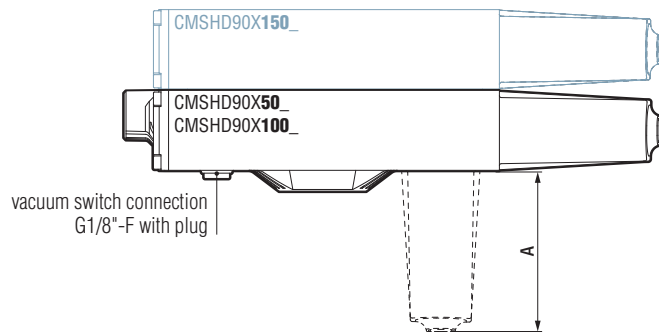

3D COVAL Data

You can access 3D files of all our products in formats compatible with the main CAD software on our website www.coval.com

CMS HD With Control

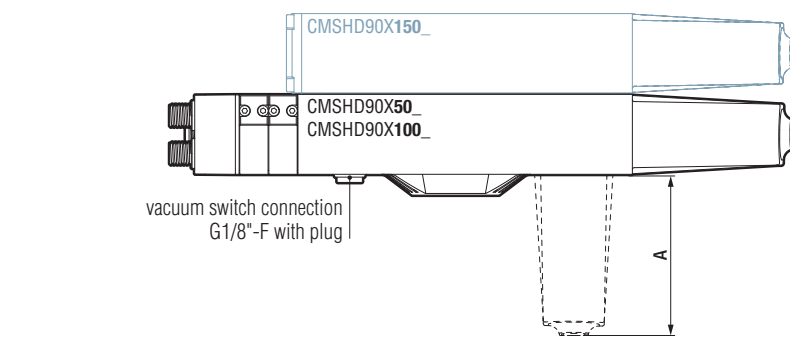
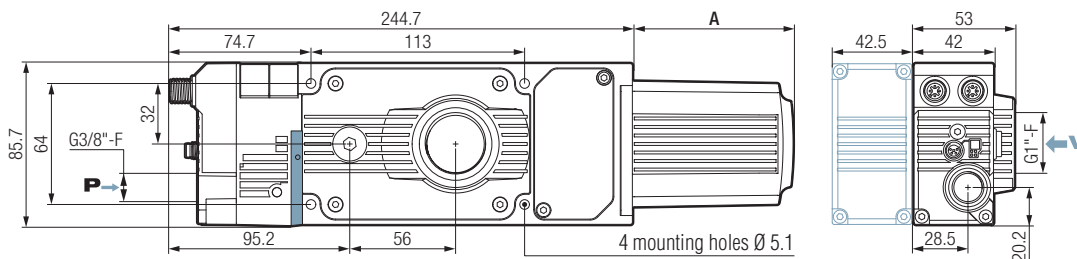

Exhaust Options

Through-type silencer
CMSHD...**K** version

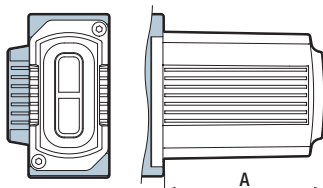

Exhaust collector
CMSHD...**E** version

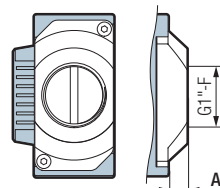

Diffuser
CMSHD...**F** version

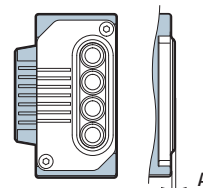

Exhaust Type	A
Silencer	85
Collector	10
Diffuser	2

CMS HD

Heavy Duty Multi-stage Vacuum Pumps

Technical specifications



NFC)))

IO-Link

- Supply: non-lubricated air, filtered to 5 microns, according to standard ISO 8573-1:2010 [3:4:4]
- Operating pressure: from 2 to 8 bar
- Optimal dynamic pressure:
 - CMSHD_**NVO** (without control): 5.5 bar
 - CMSHD90X50**S**/50**V**/100**S**/100**V**_ (with control) : 6 bar
 - CMSHD90X150**S**/150**V**_ (with control) : 6,5 bar
- Pressure connection: G3/8"-F with removable 350 µm filter screen
- Vacuum connection: G1"-F with removable 100 µm filter screen
- Connection for version with exhaust collector: G1"-F
- Vacuum switch connection G1/8"-F
- Max. vacuum: 80%
- Air suction flow rate: 700 to 1600 NI/min
- Air consumption: 220 to 620 NI/min
- Noise level:
 - with silencer:
 - CMSHD90X**50**_**K**: 59 dBA
 - CMSHD90X**100**_**K**: 62 dBA
 - CMSHD90X**150**_**K**: 67 dBA
 - with diffuser (CMSHD_**F** version): + 10 dBA to the silencer version
- Degree of protection: IP65
- Max. operating frequency: 4 Hz
- Endurance: 50 million cycles
- Weight:
 - CMSHD without control:
 - CMSHD_**50/100**: 645 g
 - CMSHD_**150**: 1330 g
 - CMSHD with control:
 - CMSHD_**50/100**: 890 g
 - CMSHD_**150**: 1575 g
- Operating temperature: from 0 to 50° C
- Materials: PA GF, brass, aluminum, steel, NBR, PU, FKM
- M12 and M8 male connectors (depending on version)

Integrated electronics

- 24 V DC power supply (regulated ±10%)
- Vacuum measuring range: 0 to 99%
- Pressure measuring range: 0 to 10 bar
- Vacuum and pressure measurement accuracy: ±1.5% of the range, compensated for temperature
- Inputs/outputs protected against reversed wiring and polarity
- Consumption: 170 mA max. (without load)
- Input/Output switching mode: PNP or PNP/NPN configurable
- Digital inputs/outputs mode (SIO) / IO-Link

DO1/DO2 output signals (only on CMSHD_**VX**_ models)

- Configurable as PNP or NPN
- NO or NC
- Breaking capacity: 330 mA
- DO1: object gripped output (factory setting 40%)
- DO2 configurable (see parameter settings)

Diagnostics

- Instantaneous vacuum level (unit transmitted over IO-Link: mbar)
- Available information: Object gripped, object lost
- Cycle counters (vacuum, blow-off, object gripped, object lost, etc.)
- Vacuum network sizing support to prevent head losses
- Clogging detection function
- Supply pressure monitoring
- Supply voltage monitoring
- Product part number and serial number
- Software version

Indicator on model CMSHD_**VOC15P**_

- Status LED for control functions:
 - green LED: vacuum control
 - orange LED: blow-off control

Information displayed on remote HMI

- LED gripping status indicator on front panel
 - Green: object gripped
 - Red: object lost
- 1.54" high-visibility color LCD display:
 - Displays vacuum level with bar graph and thresholds
 - Warns when service life has been exceeded (> 50 million cycles)
 - Explicit fault messages
 - "Suction cup" icon indicating the status of control functions:
 - Green suction cup: vacuum control
 - Orange suction cup: blow-off control
 - Red suction cup: simultaneous vacuum and blow-off control
 - Configurable display orientation: 0 - 90 - 180 - 270°

Parameter settings available with the remote HMI or IO-Link (only on CMSHD_**VX**_ models)

- Choice of blow-off type:
 - Controlled
 - Automatic timed, adjustable from 50 to 9999 ms
- Object gripped (L1) control thresholds
- Whenever required by the application, specific threshold and hysteresis settings that are different from the initial factory settings can be defined: L1 = 40%, h1 = 10%
- DO2 configurable (24 V DC) (only on CMSHD_**VXC24X**_ and **VXC18X**_ models):
 - Object lost (default)
 - or Power supply fault (below 21.6 V or above 26.4 V)
 - or Pressure fault (below 5 bar or above 8 bar)

+ Additional settings available with the remote HMI

(performed with 4-key membrane keyboard):

- Choice of language: EN, FR, DE, IT, or ES
- Choice of vacuum measurement unit (kPa, %, mbar, inHg)
- Choice of pressure measurement unit (MPa, bar, psi)
- Monostable electrical manual controls

Communication

IO-Link

- Revision: 1.1
- Transmission rate: COM3 - 230.4 kbit/s
- Min. cycle time: 1 ms
- SIO mode: Yes
- Process Data Input (PDI): 6 bytes
- Process Data Output (PDO): 1 byte
- IO device description file (IODD) available for download

NFC

- COVAL VACUUM MANAGER Mobile app available:
 - Android, version 8.1 and higher
 - iOS, version 13 and higher

8

CMS HD

CMS HD

Heavy Duty Multi-stage Vacuum Pumps

Accessories



NFC)))

IO-Link

To visualize the vacuum level

Vacuum gauge Ø 40 mm Part No. VAF11140RDM18G

- Damping: by silicone movement (patented).
- Measuring: Bourdon tube in CuSn.
- Precision: cl. 2.5 (+/- 2.5% of max. scale value).
- Frame: black ABS
- Vacuum connection: G1/8"-M

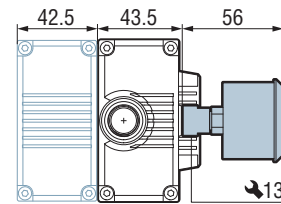

Electronic vacuum switch with 3-color display with adjustable elbow connection Part No. PSD100CPNRCOM18G

- One M8 4-pin connector.
- 1 PNP digital output (NO or NC). Max. load current: 125 mA, Max. supply voltage: 24 VDC, Residual voltage: ≤ 1.5 V.
- 1 analog output (Output voltage: 1 to 5 V $\pm 2.5\%$ F.S. (within rated pressure range), linearity: $\leq \pm 1\%$ F.S. / Output impedance: approx. 1 k Ω)
- Pressure rating range: 0 ~ -101.3 kPa.
- Pressure setting range: 10 ~ -101.3 kPa.
- Max. pressure: 300 kPa.
- Fluid: Air, non-corrosive/non-flammable gas.
- Hysteresis: adjustable.
- Response time: ≤ 2.5 ms, with anti-vibration function.
- 7 segment LCD display : 2 color (red/green) main display, orange sub-display (refresh rate: 5 times/1sec.).
- Choice of pressure unit display: kPa, MPa, kgf/cm², bar, psi, InHg, mmHg.
- Power supply voltage: 12 to 24 V DC $\pm 10\%$.
- Current consumption: ≤ 40 mA (without load).
- Repeatability (switch output): $\leq \pm 0.2\%$ F.S. ± 1 digit.
- Protection: IP40.
- Ambient temperature range: 0 – 50° C (operation).
- Adjustable elbow connection 360°: G1/8"-M

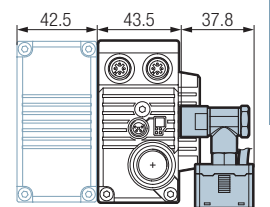
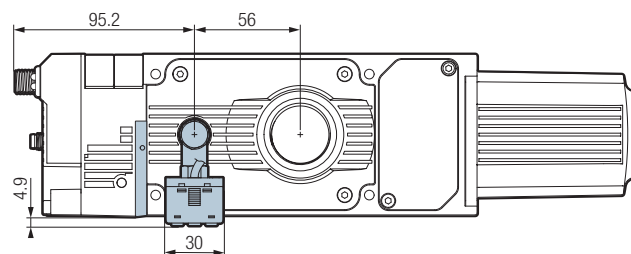
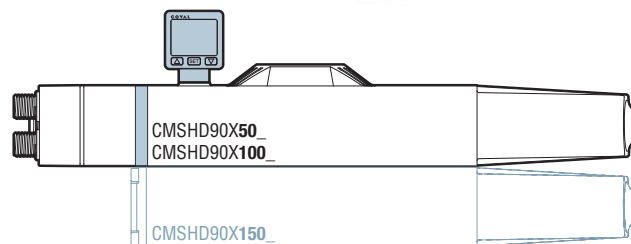
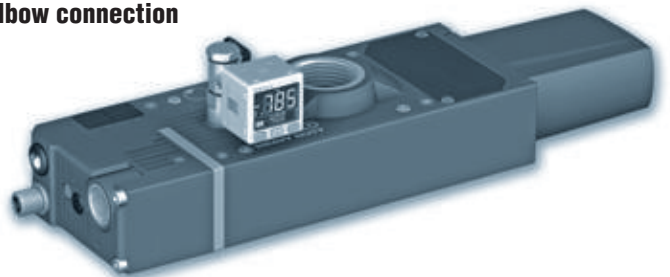

Remote HMI

(for CMSHD__VX__ only)

Part No. HMIHD1M84P

- With M8 4-pin female connector, 0.3m length

Accessories for remote HMI (see details on p. 8/71)

- Front mounting plate: Part No. **HMIHD1FIXA**
- 90° angled mounting plate: Part No. **HMIHD1FIXB**
- Side mounting plate: Part No. **HMIHD1FIXC**
- M8 4-pin, female / M8 4-pin, male, connecting cable:
 - 2 m length: Part No. **CDM8MF4PL2**
 - 5 m length: Part No. **CDM8MF4PL5**
 - Other lengths available upon request.

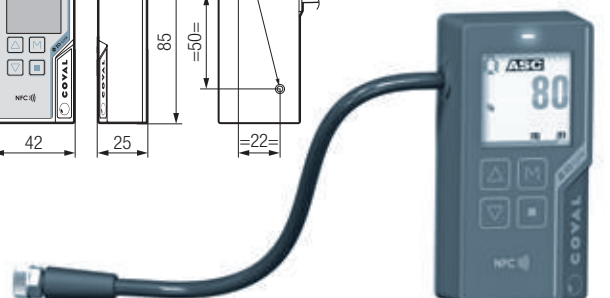
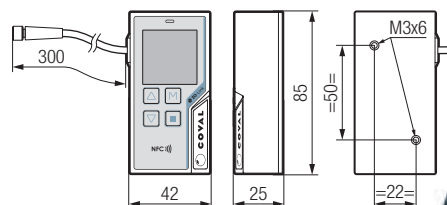

Air Amplifiers

Chapter 9

M--C



Air Amplifiers

- Operating principle based on the COANDA effect
- Bore diameter (Ø): 6, 10, 20, 30, 40 mm
- Flow rate: between 200 and 5000 NI/min depending on the supply pressure (between 1.5 and 6 bar)
- Body material: aluminum
- Recommended for gripping lightweight, porous products: foam, carpet, cakes, leather, etc.
- Transport of powdery materials: powders, granules, etc.
- Transporting small, lightweight objects: paper clips, rice, coffee, etc.
- Smoke evacuation, depressurizing chambers

P_{9/2}

MD

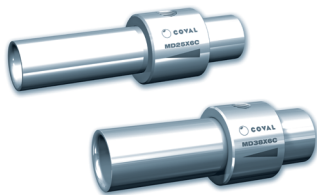

Air Amplifiers

- Operating principle based on the COANDA effect
- Bore diameter (Ø): 26,6 and 38,1 mm
- Flow rate: between 2015 and 4370 NI/min depending on the supply pressure (between 3 and 5 bar)
- Body material: aluminum
- Recommended for gripping lightweight, porous products: foam, carpet, cakes, leather, etc.
- Transport of powdery materials: powders, granules, etc.
- Transporting small, lightweight objects: paper clips, rice, coffee, etc.
- Smoke evacuation, depressurizing chambers

P_{9/5}

TVM



Pipes for Air Amplifiers

- Flexible polyurethane hose with steel spiral reinforcement.
- 4 sizes available: Ø 25, 40, 50 and 60 mm
- Anti-static properties according to DIN 53486
- Commonly used with COVAL air amplifiers (M--C series)
- High resistance to abrasion, cutting lubricant and UV rays

P_{9/6}

M--C - MD

Air Amplifiers

Applications



BLOW-OFF, CLEANING, WASTE SUCTION

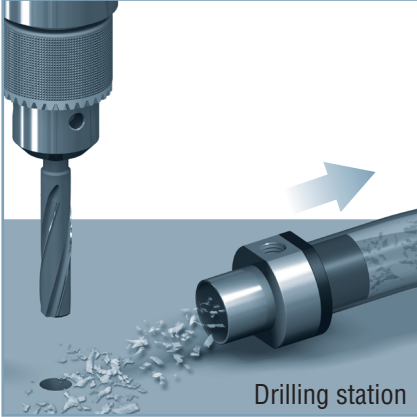

SORTING BY WEIGHT

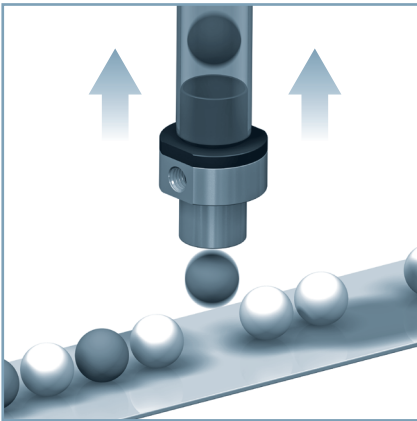

TRANSPORT OF GRANULES (rice, grains of wheat or coffee, etc.)

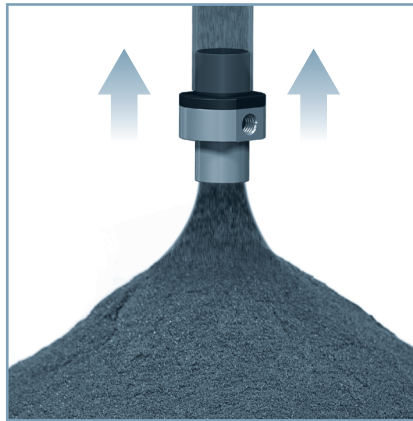

DEGASSING, SMOKE EVACUATION

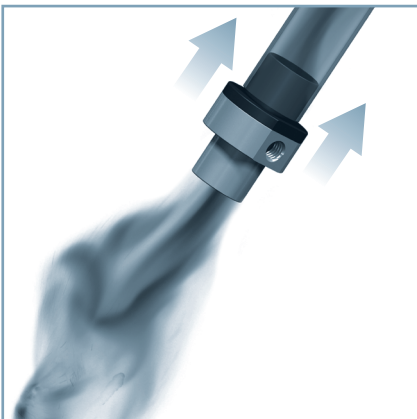

GRIPPING AND / OR UNSTACKING VERY POROUS LOADS

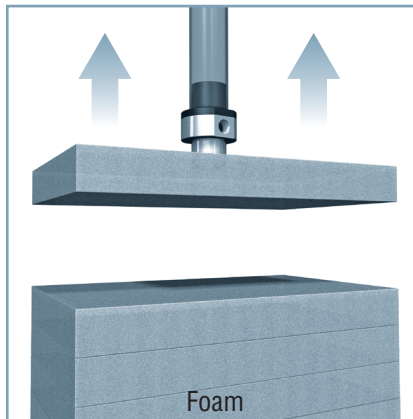

M--C - MD 9

M--C

Air Amplifiers



By virtue of the COANDA effect, the motor flux draws in air at room temperature. This physical phenomenon greatly amplifies the flow which results in very high suction produced with low consumption.

- Gripping of very porous, lightweight products: foam, carpet, cakes, leather, etc.
- Transport of powdery materials: powders, granules, etc.
- Transporting small, lightweight objects: paper clips, rice, coffee, etc.
- Smoke evacuation, chamber depressurization, etc.

Operation requirement

Compressed air filtration at 5 microns for the M6C model and 20 microns for the other models.

Characteristics

	L	N	M	C.A.	ØD	ØD1	ØD2	⚖ (g)
M 6 C	77	27.5	37	G1/8"-F	39	20	6	100
M 10 C	60	20	36	G1/8"-F	40	25	10	100
M 20 C	90	30	55	G1/4"-F	60	40	20	295
M 30 CV	105	35	72	G1/4"-F	77	50	30	495
M 40 CV	112	40	86	G3/8"-F	92	60	40	600

Note: all dimensions are shown in (mm).

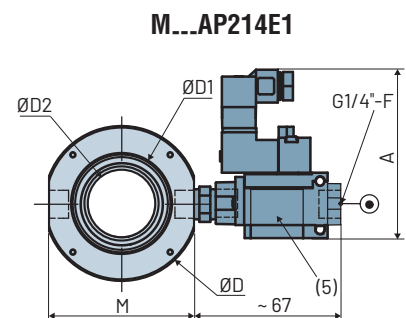
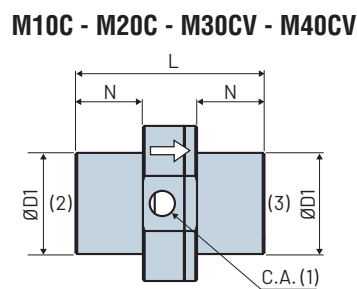
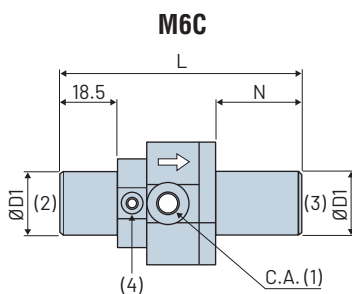

Specifications

Compressed air	Dry non-lubricated 1.5 to 5 bar
Maximum pressure drop	see table page 9/4
Materials	Aluminum body
Temperature	0°C to 80°C / 32 to 212°F

- (1) Compressed air
- (2) Suction
- (3) Discharge
- (4) M5 connector
- (5) Control valve, optional. Note: the valve is incompatible with the M40C model.
A = 77 mm for an AP2 valve + DIN connection (connector supplied)

Additional information

- Stainless steel versions are available on request.
- The 5 products present the best amplification ratio (consumption/suction). COVAL can study smaller amplification ratios (higher consumption) but higher maximum vacuum for transporting heavy objects.



For all orders, please specify:

Model + bore Ø + C.A. control + C.A. fitting + valve controls

Example : M30CVAP214E1

1: Model	2: Bore Ø	3: C.A. controls	4: Valve controls
M	6 C	6 mm	- Without control valve
	10 C	10 mm	
	20 C	20 mm	
	30 CV	30 mm	
	40 CV	40 mm	
			E1 24 V DC DIN

M--C

Air Amplifiers

Performance Curves



Maximum Vacuum / Supply Pressure

	Supply pressure / Maximum vacuum (in Bar) (in mm CE)			
	2	3	4	5
M 6 C	900	1500	2000	2600
M 10 C	200	500	700	1000
M 20 C	207	310	400	510
M 30 CV	90	130	220	280
M 40 CV	140	200	284	360

Maximum Overpressure / Supply Pressure

	Supply pressure / Maximum Overpressure (in Bar) (in mm CE)			
	2	3	4	5
M 6 C	100	550	1300	2000
M 10 C	400	700	1500	2000
M 20 C	220	340	500	600
M 30 CV	45	70	100	160
M 40 CV	96	145	199	290

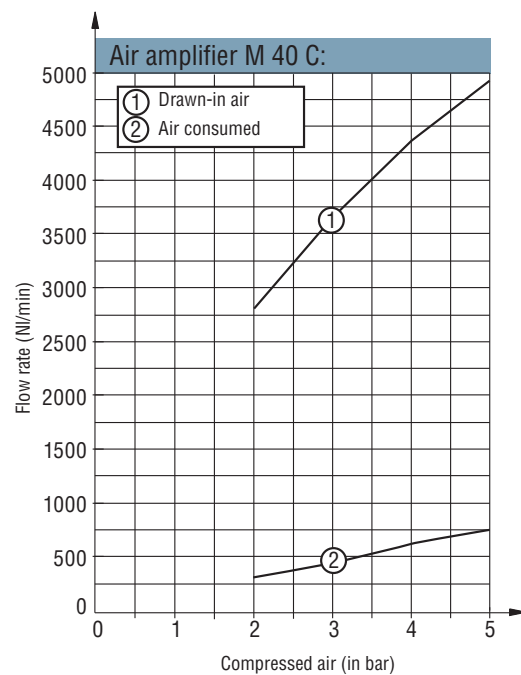
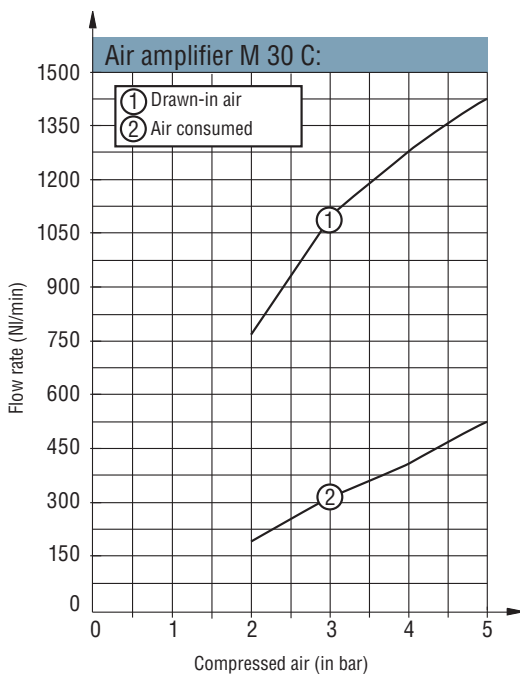
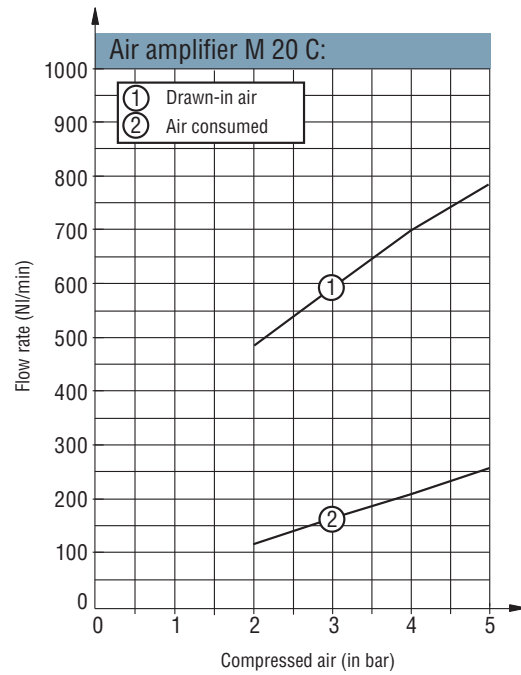
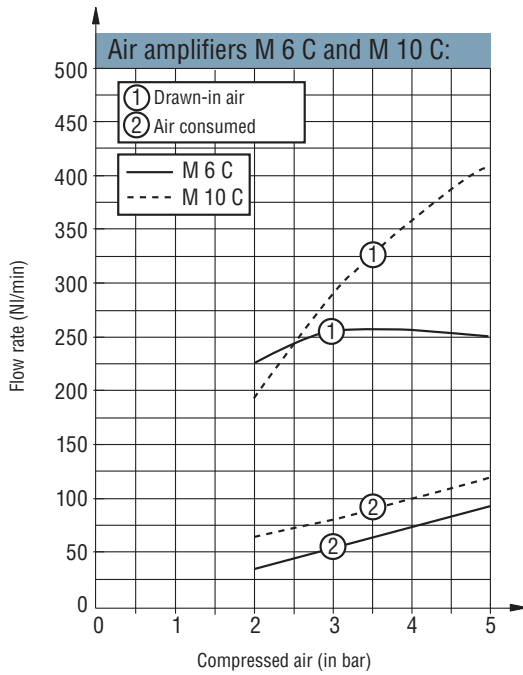

MD

Air Amplifiers



By virtue of the COANDA effect, the motor flux draws in air at room temperature. This physical phenomenon greatly amplifies the flow which results in very high suction produced with low consumption.

- Gripping of very porous, lightweight products: foam, carpet, cakes, leather, etc.
- Transport of powdery materials: powders, granules, etc.
- Transporting small, lightweight objects: paper clips, rice, coffee, etc.
- Smoke evacuation, chamber depressurization, etc.

Characteristics MD25X6C

Pressure (bar)	Level of vacuum (%)	Suction rate: (NI/min)	Consumption (NI/min)
3	6.1	2015	478
4	8.7	2200	614
5	10.9	2370	734

Characteristics MD38X6C

Pressure (bar)	Level of vacuum (%)	Suction rate: (NI/min)	Consumption (NI/min)
3	2.7	3500	478
4	4	3975	614
5	5	4370	734

Dimensions

	Ø A	Ø B	Ø C	D	E	F	(3)	(g)
MD25X6C	25.6	56.5	37.7	191	38.5	50.8	G3/8"-F	470
MD38X6C	38.1	69.9	50.8	191	38.1	50.8	G3/8"-F	640

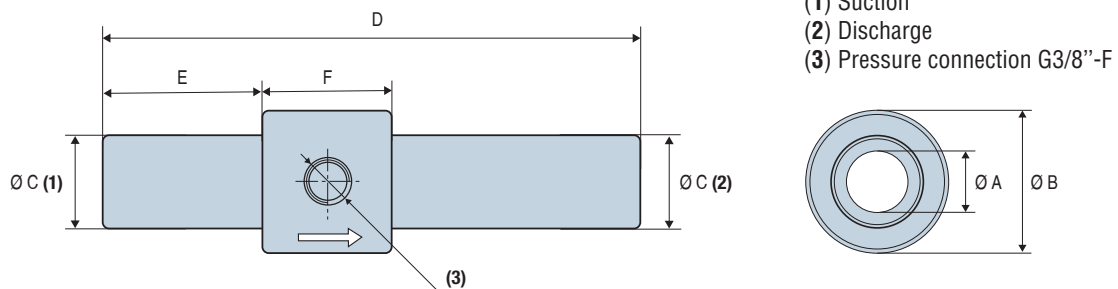

Specifications

Supply	Non-lubricated air filtered to 5 microns according to standard ISO 8573-1:2010 [4:5:4]
Operating pressure:	3 to 5 bar
Materials	Aluminum body
Temperature	°C to 80°C / 32 to 212°F

Note: all dimensions are shown in (mm).



For all orders, please specify:
Model + bore Ø + version
Example : MD25X6C

1: Model	2: Bore Ø	3: Version
MD	25 25.6 mm 38 38.1 mm	X6C

Performance Curves

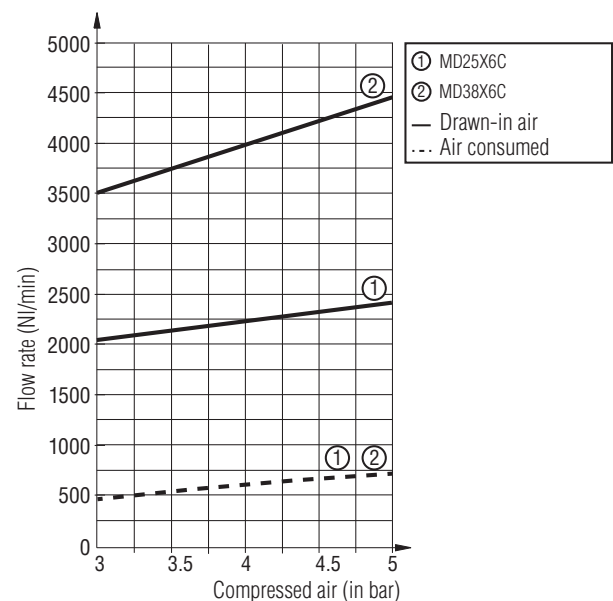



Flexible polyurethane tube reinforced with a steel spiral covered in PVC. Highly resistant to abrasion, cutting fluids and UV light.

■ Anti-static treatment in compliance with standard DIN 53486.

Specifications

Diameter D (mm)	Ø 25 - Ø 40 - Ø 50 - Ø 60
Bend radius	10 x D
Maximum pressure drop	-250 mbar
Maximum pressure	1 bar
Temperature	-40°C to 100°C / -40 to 212°F
Anti-static	R < 108 Ohm

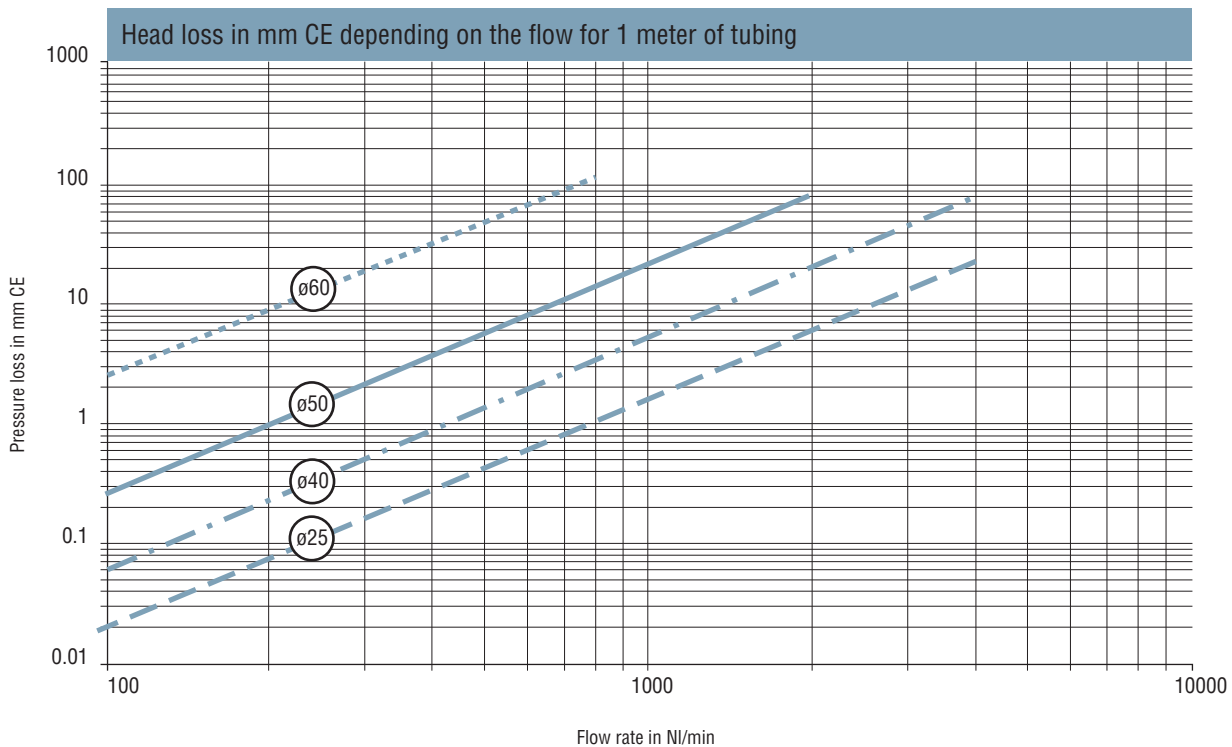

For all orders, please specify :

Model + Diameter + Length

Example: TVM4010

1: Model	2: Diameter		3: Length (m)	
TVM	25	Ø 25 mm	-	In meters
	40	Ø 40 mm	10	A ring
	50	Ø 50 mm		
	60	Ø 60 mm		

Electric vacuum pumps and Blowers

Chapter 10

PVS



Dry vane vacuum pumps

- Flow rate up to 112 m³/h
- Maximum vacuum: -150 mbar absolute (85% relative vacuum)
- Available voltages:
 - Single-phase 230 V
 - Three-phase 230/400 V
- Available in 50 or 60 Hz
- Wide range of vacuum to meet specific applications
- Vibration free
- Reduced maintenance: Oil-free operation, air cooling, self-lubricated bearings

P_{10/2}

TCL



Side-channel Blowers, single-stage and two-stage

- Flow rate up to 1250 m³/h
- Maximum vacuum: -410 mbar absolute
- Available:
 - 50 and 60 Hz
 - Single-stage and two-stage
- Wide range of vacuum to meet specific applications
- Vibration-free
- Maintenance-free: self-lubricated bearings, contactless impeller

P_{10/6}



The electric dry vane vacuum pumps in series PVS are compact and robust. They are equipped with a vacuum filter, vacuum and blow-off control valves. Their functioning is silent and vibration free and they meet a wide variety of applications.

Industry-specific applications

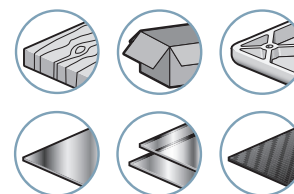

Advantages

- Wide range of vacuum to meet specific applications
- Vibration free
- Reduced maintenance: Oil-free operation, air cooling, self-lubricated bearings
- Integrated safety valve
- Available in 50 or 60 hz - Alternating or three-phase current

Characteristics

Model	Hz	m ³ /h	Vacuum (%)	kW	Rotation speed (min-1)	Voltage(V)	Amper (A)	Vacuum connection	dB(A)	 (kg)
PVS4T3	50	4.1	85	0.18	2800	175-260/300-450	1.08/0.62	G1/4"-F	59	7
	60	4.7		0.216	3360	202-300/350-520	1.08/0.62		61	
PVS8M1	50	8	85	0.35	2700	230 +/-10%	3.9	G3/8"-F	58	9.5
	60	9.1		0.42	3200		3.4		61	
PVS8T3	50	8	85	0.37	2800	175-260/300-450	2.35/1.35	G3/8"-F	58	9.5
	60	9.1		0.44	3150	202-300/350-520	2.4/1.4		61	
PVS10M1	50	10	85	0.37	1380	230 +/-10%	3.0	G1/2"-F	60	16
	60	12		0.44	1630		3.4		62	
PVS10T3	50	10	85	0.37	1420	175-260/300-450	2.3/1.33	G1/2"-F	60	16
	60	12		0.45	1700	202-300/350-520	2.35/1.36		62	
PVS16M1	50	16	85	0.55	1360	230 +/-10%	4.6	G1/2"-F	61	22.5
	60	19		0.66	1600		5.2		64	
PVS16T3	50	16	85	0.55	1420	175-260/300-450	3.8/2.2	G1/2"-F	61	22.5
	60	19		0.70	1700	3.9/2.25	64			
PVS25M1	50	25	85	0.80	1350	230 +/-10%	6.4	G3/4"-F	62	29
	60	30		1.00	1600		7.2		67	
PVS25T3	50	25	85	0.75	1430	190-255/330-440	3.9-4.85/2.25-2.8	G3/4"-F	62	29
	60	30		0.90	1690	190-290/330-500	4.65-4.25/2.7-2.45		67	
PVS40M1	50	40	85	1.10	1350	230 +/-10%	7.6	G3/4"-F	67	41
	60	48		1.620	1620		7.3		72	
PVS40T3	50	40	85	1.25	1430	190-255/330-440	5.2-6.2/3.0-3.6	G3/4"-F	67	41
	60	48		1.50	1680	190-290/330-500	6.9-5.7/4.0-3.3		72	
PVS55T3	50	55	90	2.2	1440	Δ230/Y400	8.2/4.8	G1"-F	71	76
	60	66		2.6	1705		9.0/5.2		73	
PVS100T3	50	98	90	3.0	1445	Δ230/Y400	12.1/7.0	G1" 1/2-F	75	100
	60	112		3.6	1705		12.7/7.4		77	

Version M1: Single phase (1~)

Version T3: Three-phase (3~)

Specifications

Electrical protection level	PVS4 to 40 : IP54 PVS55 and 100 : IP55
Protection class	ISO F
Materials	Steel, aluminium, polyethylene, carbone
Ambient temperature:	From 5°C to 45°C



Flow rate (m³/h) / Vacuum (%)

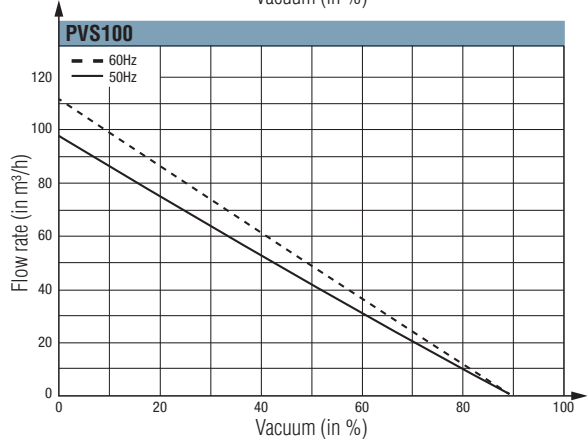
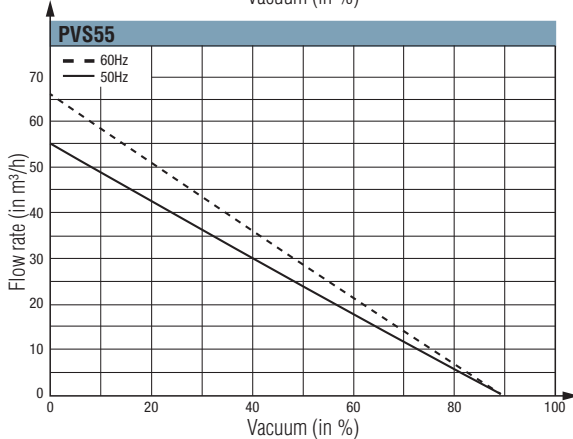
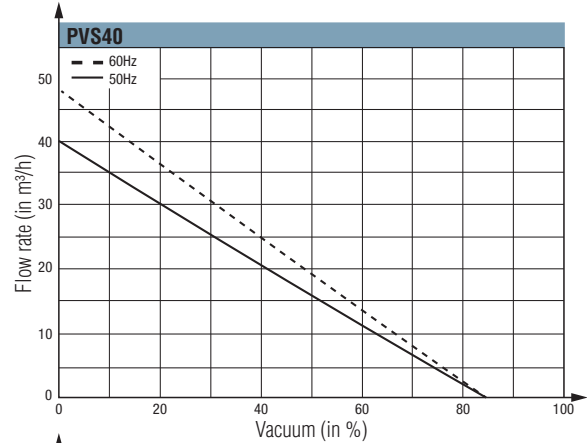
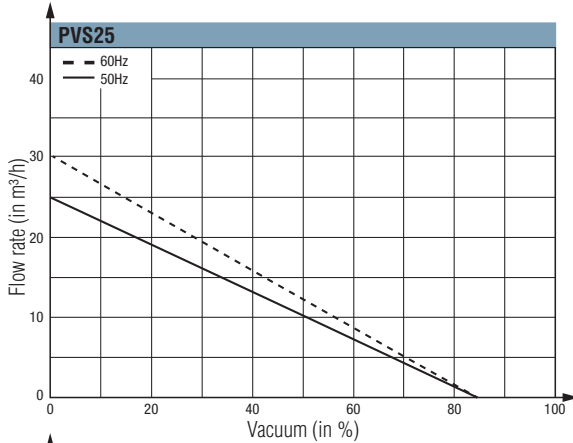
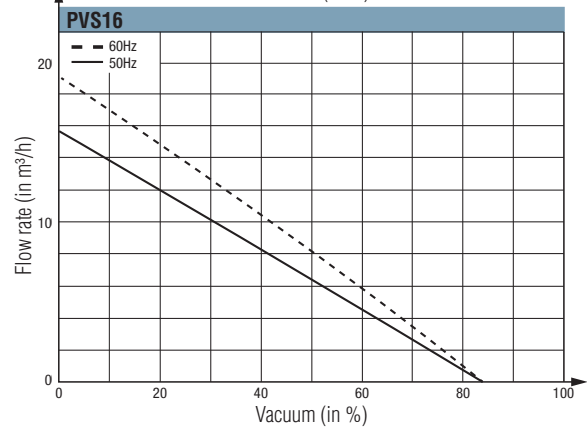
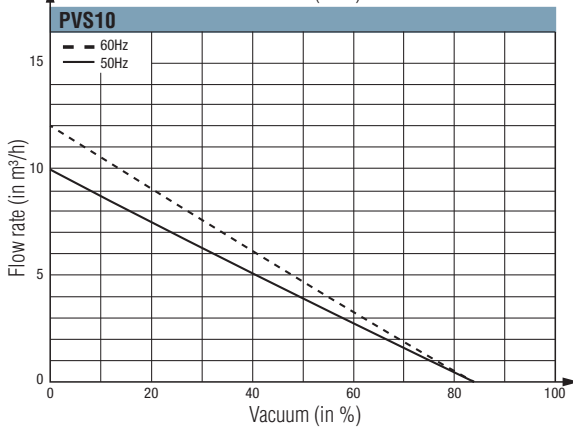
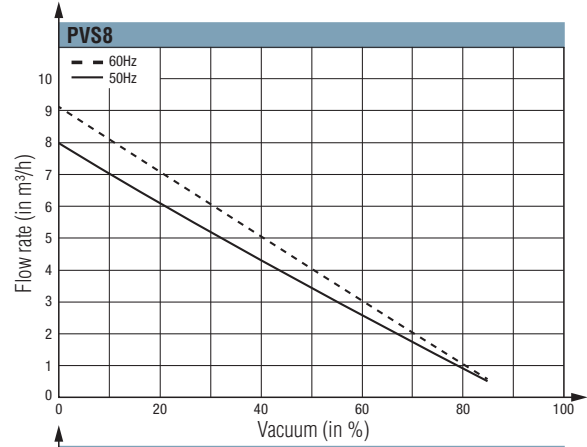
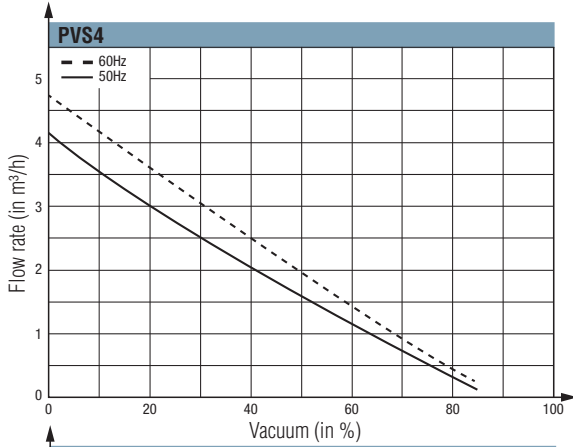

PVS

Dry vane vacuum pumps

Dimensions

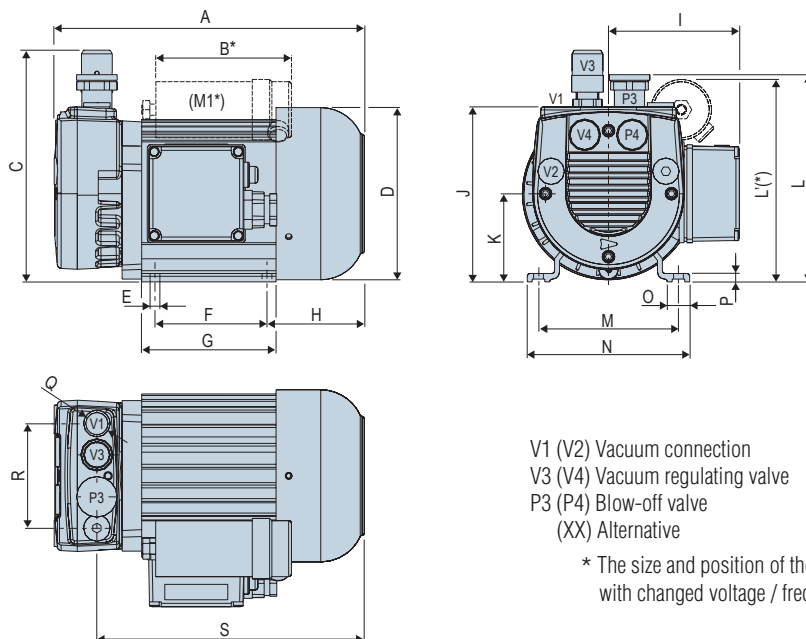

V1 (V2) Vacuum connection
 V3 (V4) Vacuum regulating valve
 P3 (P4) Blow-off valve
 (XX) Alternative

* The size and position of the capacitor can change with changed voltage / frequency.

Model	A	B	C	D	E	F	G	H	I	J	K	L	L'	M	N	O	P	Q	R	S
PVS4T3	221.5	-	165.5	125	7	80	96	69.5	93	125.5	63	148	-	100	116	16	6	G1/4"-F	74.6	191
PVS8M1	253	94	171.5	125	7	80	116	89.5	93	131	63	154	143	100	116	16	6	G3/8"-F	79	198
PVS8T3	252	-	179.5	141	7	80	101	82.5	101	139	71	162	-	112	136	16	7	G3/8"-F	79	219

10 PVS

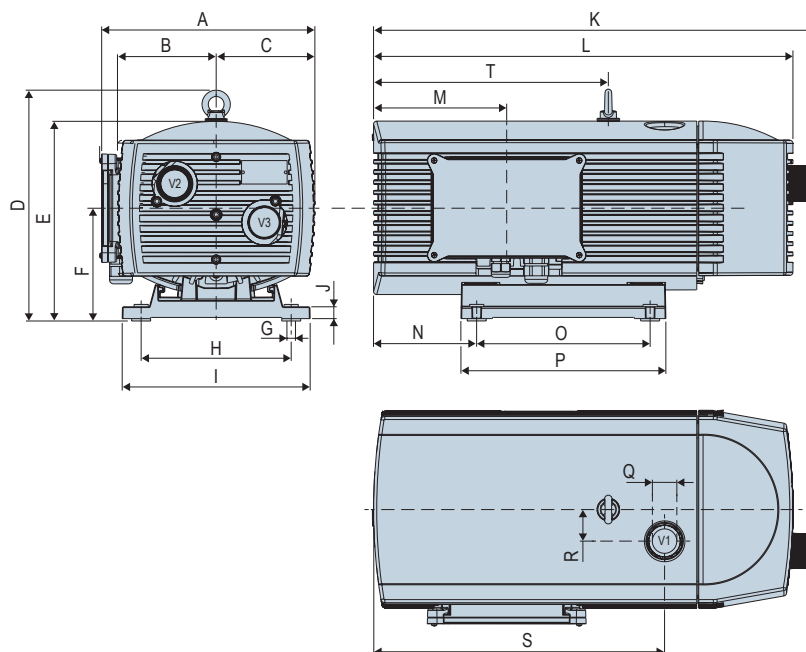

V1 Vacuum connection
 V2 Vacuum regulating valve
 V3 Exhaust air connection

Model	A	B	C	D	E	F	G	H	I	J	K	L	M	N	O	P	Q	R	S	T
PVS10	206	90	90	-	189	107	7	112	142	15	429	387	123	106	160	200	G1/2"-F	35	257	-
PVS16	231	102.5	102.5	-	205	113	7	125	155	15	452	416	151.5	73	202	242	G1/2"-F	35	291.5	263
PVS25	260	125	125	293	253	143	7	190	238	15	505	465	161.5	96	220	260	G3/4"-F	40	302	263
PVS40	270	125	125	293	253	143	7	190	238	15	572	532	168.5	131	220	260	G3/4"-F	40	363.5	298

Note : All dimensions are in mm
 The values represent the average characteristics of our products.

PVS

Dry vane vacuum pumps

Dimensions

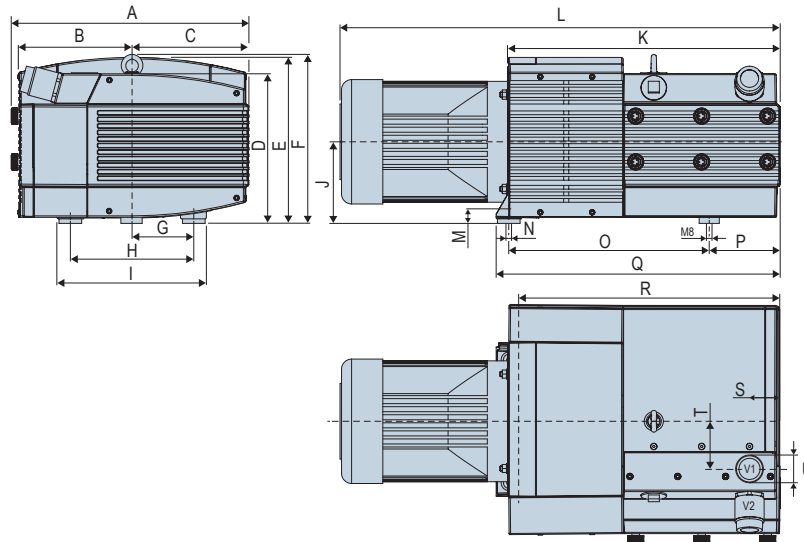

V1 Vacuum connection
V2 Vacuum regulating valve

Model	A	B	C	D	E	F	G	H	I	J	K	L	M	N	O	P	Q	R	S	T	U
PVS55T3	353	195	141	289	312	328	95	190	250	162	415	704	30	12	326	96	448	397	46	85	G1"-F
PVS100T3	470	223	230	297	330	336	122.5	245	295	162	539	843	30	12	398	140	563	501	60	95	G1"1/2-F

Note : All dimensions are in mm
The values represent the average characteristics of our products.

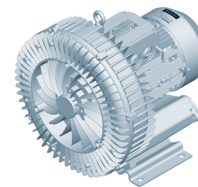

The TCL Series side-channel blowers, thanks to their high suction capacities, allow the handling of cartons, mousses, or other porous materials.

Industry-specific application



Advantages

- High suction capacity
- Vibration-free
- Maintenance-free: self-lubricated bearings, contactless impeller
- Integrated safety valve (optional)
- Wide range of vacuum to meet specific application

Characteristics

Models	Hz	m ³ /h	Vacuum (%) ¹	kW	Number of stages	Voltage (V) ²	Intensity (A)	dB (A) ³	⚖️ (kg)
TCL210T40A2S	50	210	39	4.0	2	345-415 Δ / 600-720 Y	10 Δ / 5.8 Y	72	44
	60	250	41	4.6		380-480 Δ / 660-720 Y	9.9 Δ / 5.71 Y	74	44
TCL315T43A2S	50	315	36	4.3	2	345-415 Δ / 600-720 Y	10 Δ / 5.2 Y	73	54
	60	375	32	4.8		380-480 Δ / 660-720 Y	10.4 Δ / 6 Y	76	54
TCL530T75A2S	50	530	40	7.5	2	345-415 Δ / 600-720 Y	16.7 Δ / 9.6 Y	74	86
	60	620	36	8.6		380-480 Δ / 660-720 Y	17.3 Δ / 10 Y	78	86
TCL1050T125B1S	50	1050	29	12.5	1	345-415 Δ / 600-720 Y	28 Δ / 16.2 Y	74	116
	60	1250	27	14.5		380-480 Δ / 660-720 Y	29 Δ / 16.7 Y	79	116

(1) Relief valves are available for limiting differential pressure

(2) Other voltages are available on request

(3) Noise level measurement acc. to EN ISO 3744 at a distance of 1m with hoses connected

Specifications

Degree of electrical protection	IP55
Thermal class	ISO F
Certifications	CE, UL and CSA
Materials	Housing and impeller made of die-cast aluminium
Ambient temperature	-25°C to +40°C

Accessories on demand:

- Safety valve
- Reversing valve
- Sound proofingb x



Specify the part number: TCL210T40A2S
Please refer to the characteristics table above



Suction flow (m³/h) / Vacuum (%)

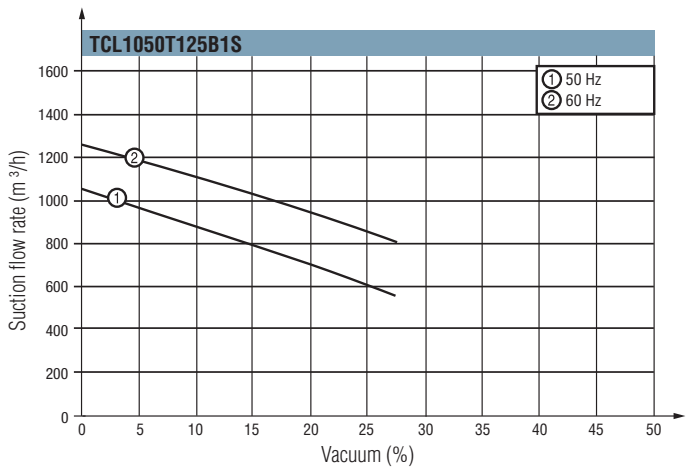
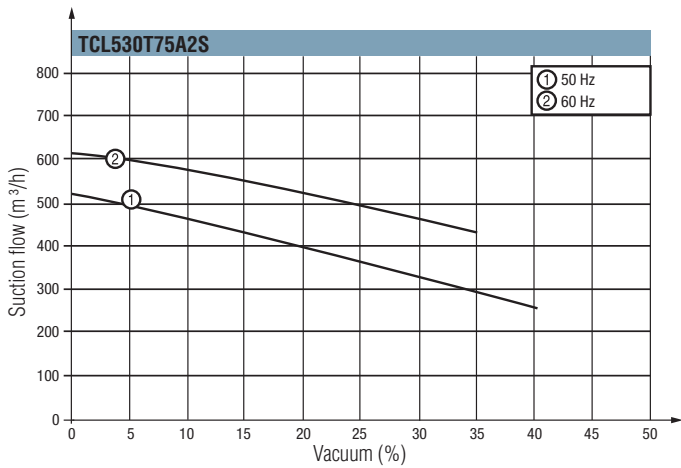
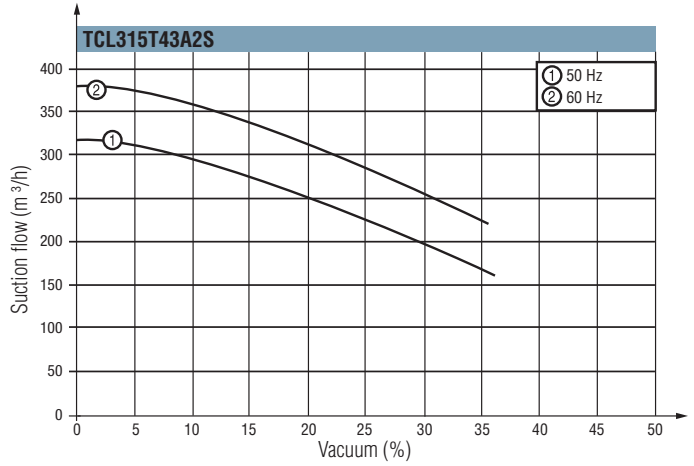
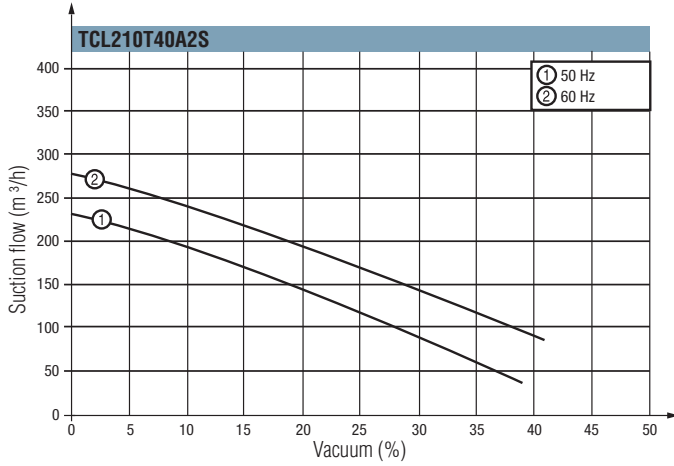

Curves are valid for continuous operation; medium: air at 15 °C, measured at inlet port and atmospheric back pressure of 1013 hPa (mbar abs.), Tolerance: ± 10%; ambient temperature : -25°C to +40°C

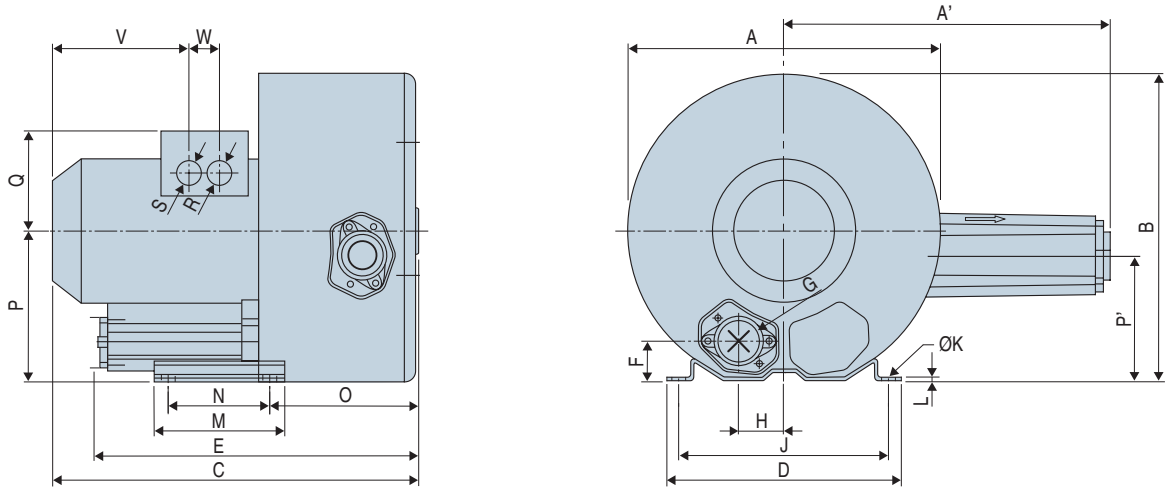

Models	A	A'	B	C	D	E	F	G	H	J	K	L	M	N	O	P	P'	Q	R	S
TCL210T40A2S	372	431	361	500	295	404	48	G 2"	60	260	14	4	155	115	171	175	144	135	4xM32x1.5	
TCL315T43A2S	426	426	420	526	325	449	54	G 2"	63	290	15	4.5	180	140	205	198	164	148	4xM32x1.5	
TCL530T75A2S	500	579	491	589	394	575	66	G 2 1/2"	76	356	15	6	217	170	236	241	200	167	4xM32x1.5	

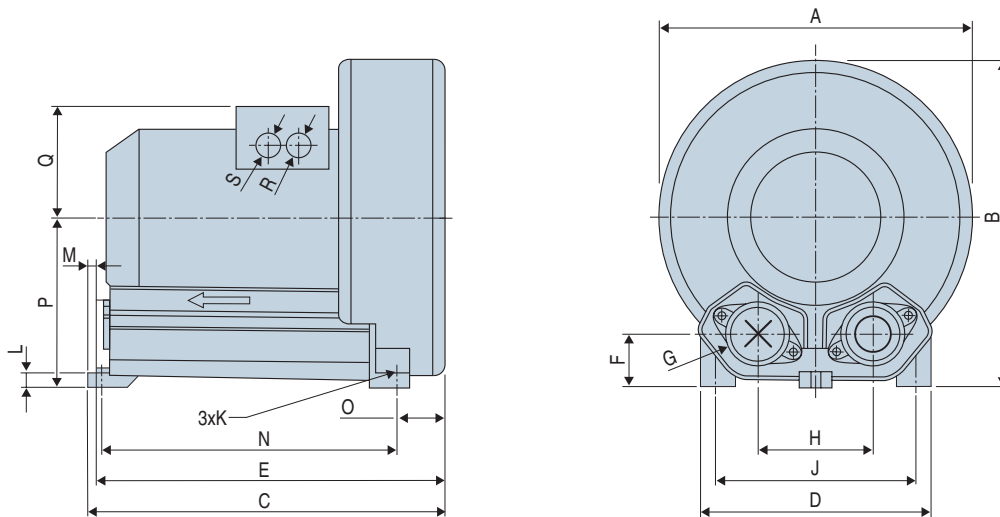

Model	A	B	C	D	E	F	G	H	J	K	L	M	N	O	P	Q	R	S
TCL1050T125B1S	560	579	645	412	613	92	G 4"	207	360	15	21	39	533	89	300	197	4xM32x1.5	

Dimensions in mm
The values are representative of the average characteristics of our products.



Vacuum Pump Accessories

Chapter 11

QR



Diffuser-type Silencers

- Pressure connection by G1/8" female fitting
- Connection to vacuum network by G1/8" male thread
- Release rate to atmosphere: about 150 NL/min
- Allows a quick and automatic release to atmosphere of a vacuum network
- Reduces cycle times
- Avoids the addition of a blow-off distributor
- Check valve control synchronized with ejector's supply

P 11/3

MS



Blow-off Devices

- Direct connection on the micro- and mini-ejectors via an M5 fitting
- Pressure connection by push fitting for Ø 4x6 or 2.7x4 tube
- 100 NL/min blow-off flow at 5 bar
- Allows direct blow-off on the VR type micro-ejectors or any other M5 fitting
- Reduces cycle times
- Avoids using a vacuum-proof distributor

P 11/4

FVI



Vacuum Filters

- A range of 8 different models of vacuum filters for optimum adaptation depending on the source of vacuum generation
- 3 filtration materials: paper, polyester and stainless steel
- 6 types of fitting, depending on the model: G3/8", G1/2", G3/4", G1"1/4, G1"1/4 and G2"
- Ideal vacuum filter for high suction flow rate vacuum sources
- Solution optimized to suit each operating environment thanks to three types of filtering material used in the filter cartridges
- A wide range adapted to your application
- Easy-to-replace cartridges in case of clogging

P 11/5

FVUM FVUG



Vacuum Filters

- A range of 4 models
- 2 sizes and 3 types of fittings: G1/4", G3/8" and G1/2"
- Transparent tank
- Transparent tank, visual checking on clogging possible
- Different models mean you can select a solution adapted to your application

P 11/7

FVG

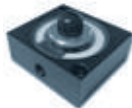

Mini Vacuum Filters

- A range of 4 models
- Ideal for mounting with micro and mini in-line ejectors
- Easy-to-replace cartridges in case of clogging

P 11/8

FVL12



In-line Filter

- 400 micron stainless steel screen
- Easy to mount in-line on the vacuum network or directly on the vacuum pump

P 11/9

FVL68



In-line Vacuum Filter

- Simple push connection for 6x8mm hose
- Quick integration into vacuum network

P 11/9

FSLI



Liquid Separator Vacuum Filters

- 2 filtration (60 and 100 microns)
- Transparent tank
- Manual drain
- We particularly recommend using the FSL series liquid separator vacuum filters to retain liquid and particles that may be found in a vacuum network

P 11/10

Vacuum Pump Accessories

Chapter 11

SIL GV

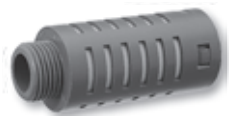

Diffuser-type Silencers

- Noise reduction of between 30 and 39 dBA
- Passage of air through a soundproof material
- Available in 4 sizes
- 4 types of fitting, M-5F, G1/8", G1/4", G 1/2"
- Very good sound reduction
- Air outlet gently diffused
- Reduced size

P_{11/11}

SIL K--C



Through Type Silencers

- Through type silencer
- Noise reduction of between 30 and 33 dBA
- Noise absorbed laterally by soundproof textile
- Available in 5 sizes
- 3 types of fitting, G1/8", G1/4", G1/2"
- Noise reduction mastered
- No clogging
- No pressure loss
- Ideal for dusty environments
- Possibility of collecting the exhaust

P_{11/11}

CD CC



Screw-type Electrical Connectors

- M8 and M12
- 4 and 5 poles
- Straight or elbow(90°)

P_{11/12}

QR

Quick Release Device

Quick Release



Economic solution developed especially for micro ejectors to respond to applications requiring a quick release back to atmospheric pressure of a vacuum network with reduced space and weight.

Operating:

When the ejector is pressurized to generate vacuum it applies to the internal valve of the QR18 and blocks atmospheric evacuation. When the pressure is interrupted to stop vacuum generation, the network is automatically vented to atmosphere.

Advantages

- Allows a quick and automatic release to atmosphere of a vacuum network.
- Reduces cycle times
- Avoids the addition of a blow-off distributor.
- Check valve control synchronized with ejector's supply
- No energy consumption
- Easy disassembly for cleaning

Specifications

Model	Fitting	Weight (g)
QR18	G1/8"	35

- Pressure connection by G1/8" female fitting
- Connection to vacuum network by G1/8" male thread
- Operating pressure: 2 to 7 bar
- Release rate to atmosphere: about 150 NI / min
- Nominal diameter : 4mm
- Materials : aluminium, nitrile (NBR), brass, steel
- Operating temperature : 0 to 50°C



Dimensions

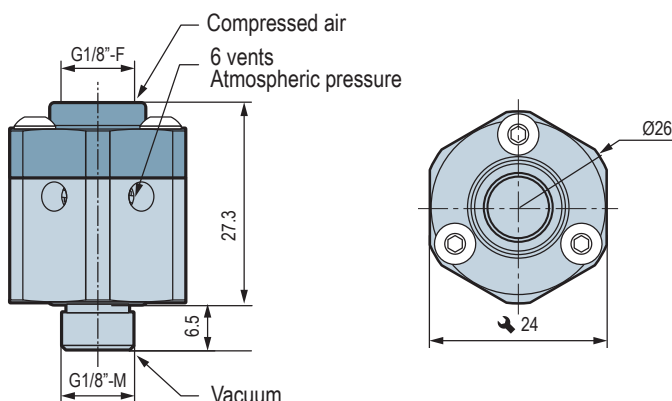

Pneumatic assembly

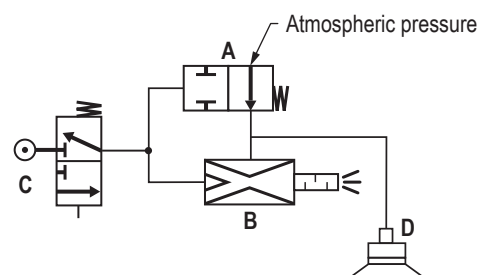

- A: QR18 Quick Release device
- B: Ejector (Venturi).
- C: Compressed air distributor
- D: Vacuum network

Note: All dimensions are in mm



Specify the part number: QR18
Please refer to the characteristics table above

MS

Quick Release Devices



Economical solution developed especially for Coval micro-ejectors to suit applications requiring blow-off combined with very reduced size and weight. This device enables the user to connect the compressed air network directly onto the M5 push fitting.

Advantages

- Allows blow-off on VR or any other M5 fitting
- Reduces cycle times
- Avoids using a vacuum-proof distributor.

Technical Characteristics

Model	Push fitting	L
MS2M5	Ø 2.7x4	25.8
MS4M5	Ø 4x6	28.10

- Pressure connection by push fitting for Ø 4x6 or 2.7x4 tube
- Connection to the vacuum network by M5 male threaded fitting
- Blow-off flow rate at 5 bar: 100 NI/min
- Materials: polyamide PA 6.6 + brass (CuZn) + nitrile (NBR)

Dimensions

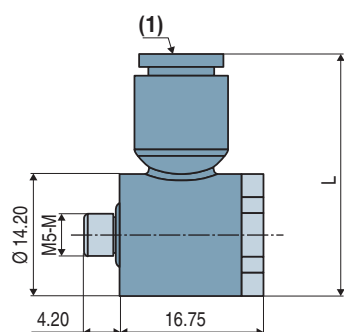

(1) Push fitting

Pneumatic Diagram

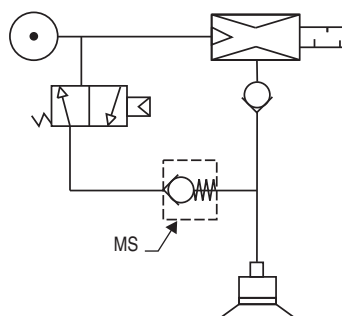

 For all orders, please specify:
Model + Push fitting
e.g. : MS2M5

1: Model	2: Push fitting
MS2M5	Ø 2.7x4
MS4M5	Ø 4x6

Note: all dimensions are shown in (mm)

FVI

Vacuum Filters



The FVI range is compatible with pneumatic vacuum generators (venturi) or electric vacuum pumps (the FVI 2 model is suitable for a suction turbine). Each filter is fitted with an interchangeable cartridge treated to guarantee long life expectancy for the whole unit.

The filtering element consists of a 5 micron filter (made of paper for version C), which is sufficient to protect pumps and venturi under normal operating conditions.

Note: For filtration leaving large deposits (powder), mount the filter horizontally or upside down.

Important: These filters are designed for vacuum. They cannot withstand pressure greater than atmospheric pressure.

Filter cartridge available in 3 versions: paper, polyester and stainless steel.

Characteristics

Models	A	H	R	Flow rate (Nl/min)	Weight (g)
FVI 38	79	76	G3/8"-F	400	270
FVI 12	101	86	G1/2"-F	600	600
FVI 34	101	86	G3/4"-F	600	600
FVI 114	135	96	G1"1/4"-F	1400	1050
FVI 114 G	173	156	G1"1/4"-F	2400	1850
FVI 2	201	258	G2"-F	5000	3900

Note: all dimensions are shown in (mm)

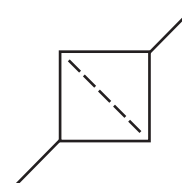
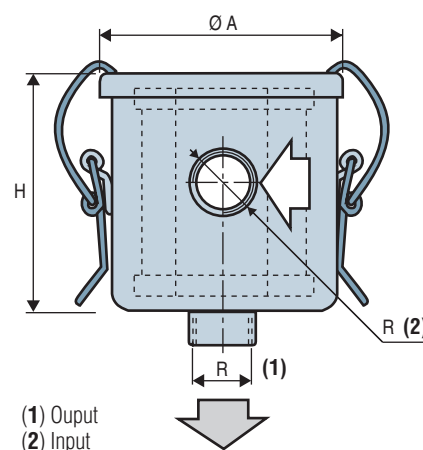

Specifications

Body material	Stamped steel sheet
Treatment	Black paint
Filtration	5 microns with a paper cartridge 3 microns with a polyester cartridge 60 microns with a stainless steel cartridge
Pressure loss	2 to 4% vacuum with a new filter 5 to 7% vacuum with average clogging

FVI

11



For all orders, please specify:
Model + Fitting + Filtering material
e.g.: FVI34P

1: Model	2: Fitting	3: Filtering material
FVI	38	G3/8"
	12	G1/2"
	34	G3/4"
	114	G1"1/4"
	114G	G1"1/4"
	2	G2"
		C Paper P Polyester I Stainless steel



Filter

Models	Use
FVI 38	GVP 20
FVI 12	GVP 25 - 30 - PVR 6 (6 m³/h)
FVI 34	Vacuum pumps: 10/16 m³/h
FVI 114	Vacuum pumps: 20/25 m³/h
FVI 2	Turbine

Filtration

COVAL offers three filtration principles:

Model C: CE filtration element

- Paper cartridge with 5 micron filtration.
- No damp cleaning process possible.
- Incompatible to very humid conditions

Model P: PE filtration element

- Polyester cartridge with 3 micron filtration.
- Damp cleaning possible.

Model I: IE filtration element

- Stainless steel cartridge, 60 micron filtration.
- For use in very damp environments (water, liquid)

Accessories

Models	Replacement cartridge (*)	External Ø	Internal Ø	H2
FVI 38	FVI 38*E	51	23	57
FVI 12	FVI 12*E	64	38	68
FVI 34	FVI 12*E	64	38	68
FVI 114	FVI 114*E	98	60	71
FVI 114 G	FVI 114G*E	125	64	125
FVI 2	FVI 2*E	149	88	221

(*) Specify the filter material: **C** (paper) ; **P** (polyester) ; **I** (stainless steel).

Note: all dimensions are shown in (mm)

Replacement cartridge

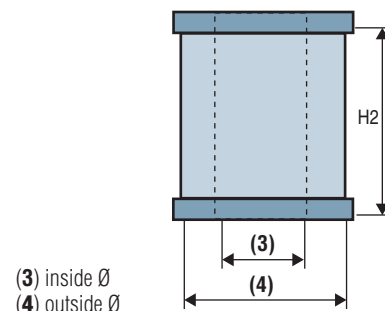

(3) inside Ø
(4) outside Ø

Other Models

FVG 11-2-3-5-6 series vacuum filters, for micro-ejectors

- Polyester cartridge
- See page 11/8

FVUM 14-38 series vacuum filters for GVP 12 and 15 vacuum pumps

- FVUG 38-12 vacuum filters, in-line stainless steel cartridge for GVP 15 and 25 vacuum pumps and small electric vacuum pumps.
- See page 11/7

FVUM. FVUG

In-line Filters

The advantage of this range of filters is that they are equipped with a transparent tank so that clogging is visible.



Characteristics

Models	A	B	C	D	G	Flow rate (NI/min)
FVUM 14	75	60	49.5	49.5	G1/4"-F	150
FVUM 38	75	64	49.5	51.5	G3/8"-F	350
FVUG 38	90.5	126.5	75	112.5	G3/8"-F	350
FVUG 12	90.5	130	75	114.5	G1/2"-F	500

Note: all dimensions are shown in (mm)

Operating range

■ - 1 to 10 bar

Specifications

Body material	High: nylon 6.6 Tank: transparent polyamide
Filtration	Two options available: 50 micron stainless steel grill or Polyethylene 80 micron
Temperature	0 to 50°C

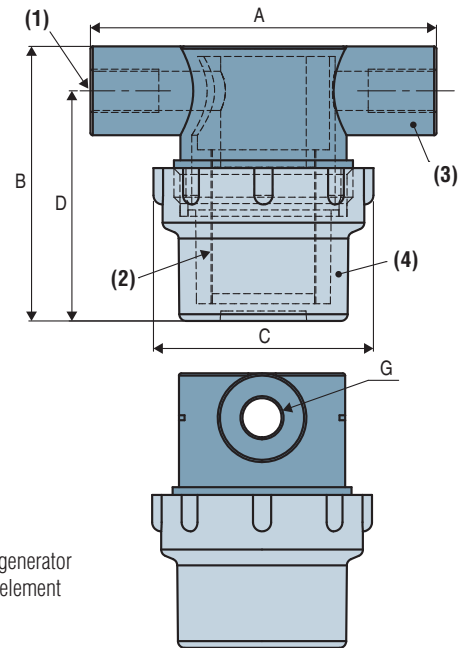
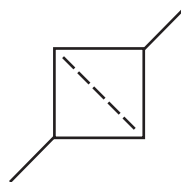

- (1) Vacuum generator
- (2) Filtering element
- (3) Body
- (4) Tank

 For all orders, please specify:
Model + Size + Fitting + Type of cartridge
e.g.: FVUG38P

1: Model	2: Size		3: Fitting		4: Cartridge	
FVU	M	Mini	14	G1/4" for M series	-	Stainless steel
	G	Large	38	G3/8" for M and G series	P	Polyethylene
			12	G1/2" for G series		



To order a replacement filtering element, please specify:
e.g.: FVUM12E

Model	Reference of the filtering element
FVUM14 and 38	FVUM12E (Stainless steel)
FVUG12 and 38	FVUG12E (Stainless steel)
FVUM14P and 38P	FVUM12PE (Polyethylene)
FVUG12P and 38P	FVUG12PE (Polyethylene)

Mounting bracket for vacuum filter

Model	Designation	Material
FVUFIXM	Mounting bracket for filter FVUM	Stainless steel
FVUFIXG	Mounting bracket for filter FVUG	Stainless steel

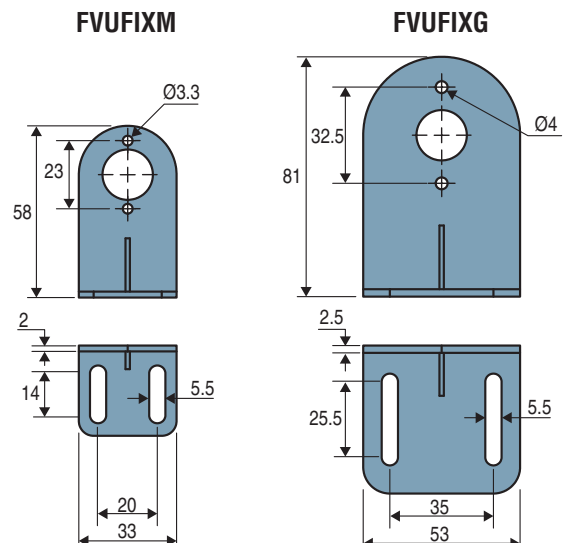

 Please specify part n°, eg: FVUFIXM
Please see table above

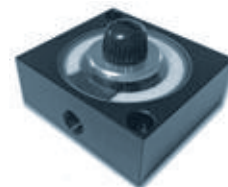

FVG series vacuum filters are especially recommended for fine filtration. Their light weight allows easy on-board installation.

Mini-filters

Models	Vacuum pumps
FVG 3	GVP 10 - VR 07 - VR 09
FVG 5	GVP 12 and 14
FVG 6	GVP 20

Characteristics

Models	A	B	C	E	F	G	D1	D2
FVG 3	8	20.5	33.8	55	50	18	G1/8"-F	G1/8"-F
FVG 5	12.5	25	42	65	50	23	G1/4"-F	G1/4"-F
FVG 6	15	30	47	70	60	23	G3/8"-F	G3/8"-F

Note: all dimensions are shown in (mm)

Specifications

Operating pressure	-1 to 5 bar
Temperature	0 to 60 °C
Filtration (μ)	FVG 3-5-6 : 40
Weight (g)	FVG 3/5/6: 70/138.5/220
Material	Body : POM Hood : Polycarbonate Seal : Nitrile (NBR) Screws / large washers : Polyethylene and plated steel Filter : Porex

Accessories

Replacement cartridges: interchangeable filtration element.
Add E to the filter model reference to order the replacement cartridge.

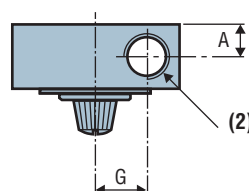
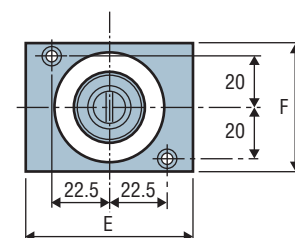
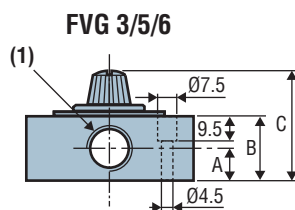

(1) D1 (input)
(2) DE (Output)

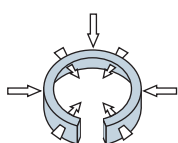
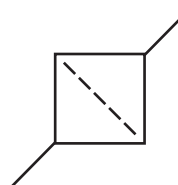

Filtration angle 300°



For all orders, please specify:
Model + Type + Filter or Cartridge
e.g.: FVG5

1: Model	2: Type	3: Filter or Cartridge
FVG	3 FVG 3 5 FVG 5 6 FVG 6	- Filter E Cartridge

FVL 12

In-line Filter



The FVL12 in-line filter allows quick integration for vacuum pumps GVP and GEMP.

Specifications

Material	Body: Nickel-plated brass Grille: 400 micron stainless steel
Weight	50 g

Mounting on option

The FVL 12 series in-line filter can also be mounted as a GVO P option on GVP series vacuum pumps. See page 7/7.

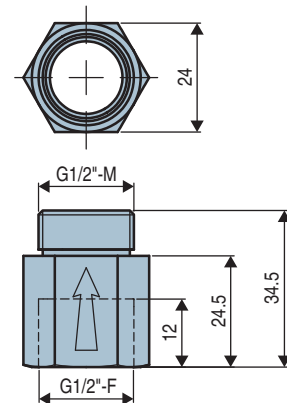

Note: all dimensions are shown in (mm)



For all orders, please specify: FVL12

FVL 68

In-line Vacuum Filter



The FVL68 in-line filter ensures quick integration into a vacuum network, thanks to its push fitting for 6 x 8 calibre pipes.

Ideal for protecting a vacuum generator from normal clogging. The FVL is equipped with a 400 micron filtering grille.

Applications

The FVL68 in-line filter is ideal for protecting LEM mini vacuum pumps. Installation directly onto the vacuum outlet of the pump, using a 6 x 8 push fitting.

Industry-specific applications

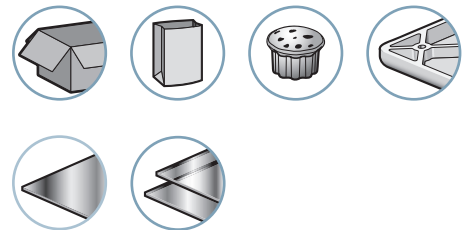

Specifications

Material	Body: POM Grille: 400 micron stainless steel Push fitting Brass – Steel and polymer
Weight	7 g.

Note: all dimensions are shown in (mm)



For all orders, please specify: FVL68

Dimensions

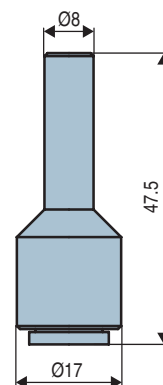

Example usage



FSLI

Liquid Separator Vacuum Filter



We particularly recommend using the FSLI series liquid separator vacuum filter to retain liquid and particles that may be found in a vacuum network. The filtering element consists of a 50 micron stainless steel filter and protects the vacuum generator under normal operating conditions.

Advantages

- Transparent tank that makes clogging visible.
- Manual drain in the bottom of the tank used to remove any liquid and dirt (Note: This operation must only be carried out when the vacuum network is at atmospheric pressure).

Characteristics

Model	Fitting	Stainless steel filtering	Flow rate ⁽¹⁾ (NI/min)
FSLI38X50	G3/8"-F	50 µ	350

(1) The flow rate may vary according to the viscosity of the liquid drawn in.

Specifications

Material	Lid: molded aluminium Tank: transparent polycarbonate Filter cartridge: stainless steel Accessories: stainless steel, brass and nickel-plated brass Seal: nitrile
Filtering	Two options available: 50 microns
Operating range	-1 to 2 bar
Pressure max.	2 bar
Temperature	0 to 50 °C

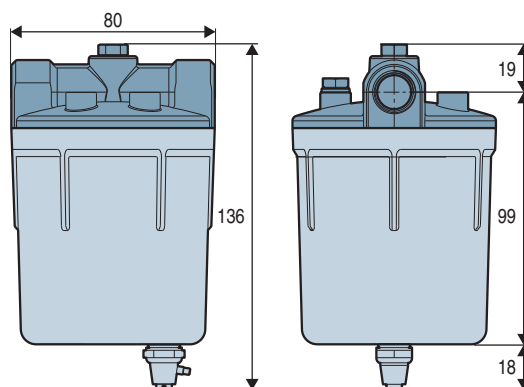

For all orders, please specify:

- For complete filter: FSLI38X50
- For a replacement filtering element: FVUM12E

Mounting bracket for FSLI series liquid separator filter

Material: zinc-plated steel

Model

FSL38FIX Mounting bracket for FSLI filter

Note: Supplied with two M6 screws to mount bracket on filter.

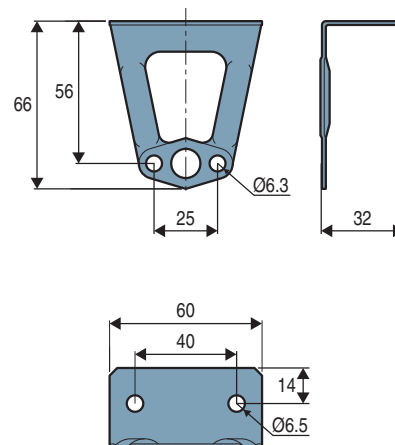

Specify part n°: FSL38FIX

Note: all dimensions are shown in (mm)

SIL GV. SIL K -- C

Diffuser Type Silencers, Through-type Silencers



From when it was founded, COVAL has always given particular attention to reducing the noise of vacuum pumps and improving their performance.

Often copied, never equalled, the acoustic performance of COVAL vacuum pumps stems from the inside shape of the venturi system and the innovative design of the hit-tech soundproof materials used for the silencers.

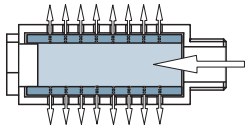

Diffuser type silencer

- Very good noise reduction
- Air output gently diffused.

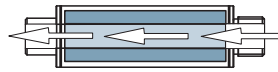

Through-type silencer

- Noise reduction mastered.
- No clogging.
- No pressure loss.

SIL GV series diffuser-type silencers

Noise reduction by breaking up the air jet in a baffle inside the diffuser. Passage of air through a soundproof material.



Characteristics

Models	ØA	B	ØC	Weight (g)	Medium-level noise reduction (dBA)
SIL GV 10 M5 F	18	36	M5-F	5	30
SIL GV 10	18	36	G1/8"-M	5	30
SIL GV 15	20	46	G1/4"-M	10	35
SIL GV 20	30	62	G1/2"-M	29	39

Note: all dimensions are shown in (mm)

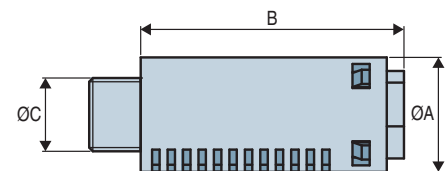

Specifications

Material	POM (Polyoxymethylene) + interior: Textile soundproof material
Temperature	-10 to 50 °C

SIL K -- C series through-type silencers

- Noise absorbed laterally by soundproof material.
- Free output without pressure loss or clogging.



Characteristics

Models	ØA	B	ØC	Weight (g)	Medium-level noise reduction (dBA)	Materials
SIL K 18 C	20	68	G1/8"-M	22	33	thread: aluminum
SIL K 14 C	20	68	G1/4"-M	25	31	tube: PA6, 30% GF
SIL K 38 C	30	121	G3/8"-M	90	33	polycarbonate, 15% GF
SIL K 12 C	30	121	G1/2"-M	92	33	
SIL K 12 CS	30	54	G1/2"-M	61	28	

Note: all dimensions are shown in (mm)

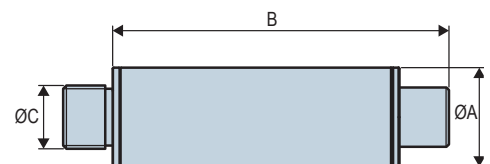

Specifications

Material	Anodised aluminium and black Polyamide or Polycarbonate (according to Ø) interior: Textile soundproof material
Temperature	-10 to 50 °C

Special:

COVAL develops tailor-made through-type silencers according to specifications, male or female fitting, length, diameter, characteristics on request.

CD-CC

Connectors

M8 / M12 / RJ45



Single-Ended Cordsets

Cable properties

Models	Connection	Number of conductors	Orientation	Cable length	Cable
CDM8	M8 - Female - A-Coded	4	Straight	2 m	PUR
CDM8N	M8 - Female - A-Coded	4	Straight	0.5 m	PVC
CCM8	M8 - Female - A-Coded	4	Elbow	2 m	PVC
CDM12N	M12 - Female - A-Coded	4	Straight	2 m	PUR
CDM12L5	M12 - Female - A-Coded	4	Straight	5 m	PVC
CCM12	M12 - Female - A-Coded	4	Elbow	2 m	PVC
CCM12L5	M12 - Female - A-Coded	4	Elbow	5 m	PVC
CDM125PL2	M12 - Female - A-Coded	5	Straight	2 m	PUR
CDM125PL5	M12 - Female - A-Coded	5	Straight	5 m	PUR
CCM125PL2	M12 - Female - A-Coded	5	Elbow	2 m	PUR
CDM128PL2	M12 - Female - A-Coded	8	Straight	2 m	PUR



Specifications

Cable : Drag chain compatible

Open end

Double-Ended Cordsets

Characteristics

Models	Connection 1	Connection 2	Number of conductors	Orientation	Cable length	Specifications	Cable
CDM8MF4PL2	M8 - Male - A-Coded	M8 - Female - A-Coded	4	Straight	2 m	-	PUR
CDM8MF4PL5	M8 - Male - A-Coded	M8 - Female - A-Coded	4	Straight	5 m	-	PVC
CDM8M12	M8 - Female - A-Coded	M12 - Male - A-Coded	4	Straight	1 m	-	PVC
CDM8MM12F4PL2	M8 - Male - A-Coded	M12 - Female - A-Coded	4	Straight	2 m	-	PVC
CDM8MM12F4PL5	M8 - Male - A-Coded	M12 - Female - A-Coded	4	Straight	5 m	-	PUR
CDM8FFL05	M8 - Female - A-Coded	M8 - Female - A-Coded	4	Straight	0.5 m	COVAL bus cable	PUR
CDM8FFL1	M8 - Female - A-Coded	M8 - Female - A-Coded	4	Straight	1 m	COVAL bus cable	PUR
CDM8FFL2	M8 - Female - A-Coded	M8 - Female - A-Coded	4	Straight	2 m	COVAL bus cable	PUR
CDM8FFL4	M8 - Female - A-Coded	M8 - Female - A-Coded	4	Straight	4 m	COVAL bus cable	PUR
CDM8RJ45L2	M8 - Female - A-Coded	RJ45	4	Straight	2 m	Cat 5 shielded Ethernet cable	PUR
CDM8RJ45L5	M8 - Female - A-Coded	RJ45	4	Straight	5 m	Cat 5 shielded Ethernet cable	PUR
CDM8RJ45L10	M8 - Female - A-Coded	RJ45	4	Straight	10 m	Cat 5 shielded Ethernet cable	PUR
80003053	M8 - Female - A-Coded	M8 - Female - A-Coded	4	Straight	1 m	Cat 5 shielded Ethernet cable	PUR



CDM8MF4PL_



CDM8M12



CDM8MM12F4PL_



CDM8FFL_



CD8RJ45L_



80003053

Specifications

Cable : Drag chain compatible



Specify part n°, eg: CDM8N
Refer to characteristics table above

Vacuum Switch Range

Chapter 12

PSK



Mini Vacuum Switch

- 1 digital output
- Adjustable vacuum threshold
- 3 vacuum port sizes available
- M8 connection

- Ultra-compact and lightweight
- LED visual indicators

P_{12/3}

PSA 100 C



Electronic Vacuum Switch with Display

- 2 configurable digital outputs
- NO or NC outputs
- Adjustable hysteresis
- IP 65

- The PSA100 C electronic vacuum switch is the most efficient vacuum measuring component in the COVAL range.
- It can be easily installed on all machines and robots, etc. thanks to its compact lightweight design.

P_{12/4}

PSD 100



Vacuum Switch with 3-colour Display

- 1 to 5 VDC analog output
- Response time: < 5ms
- 2 vacuum fittings available
- M8 connection

- The compact PSD100 electronic vacuum switch is used to check the exact level of vacuum in the system.
- Analog output

P_{12/5}

PSP 100 CX

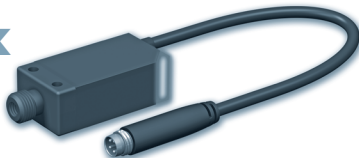

Electronic Vacuum Switch

- 1 configurable digital output
- Response time: < 5ms
- 2 vacuum fittings available
- M8 connections

- The PSP100 electronic switch reduces size while accurately monitoring the vacuum level
- Adjustable digital output and hysteresis.

P_{12/7}

PSP 100 ANA

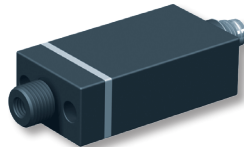

Electronic Vacuum Switch Analog Output

- 1 Analog output from 1V to 5 VDC
- Response time: < 5ms
- 2 vacuum port sizes available
- M8 connections

- The PSP100 ANA electronic switch reduces size while accurately monitoring the vacuum level
- Analog output

P_{12/8}

PSE 100 E



Electric Vacuum Switch

- Adjustment range -300mb to -850mb
- All voltages
- Cable or M12 connector outputs

- The PSE 100 E vacuum switch with electric output is used to check the vacuum level in the circuit.
- It is adapted to all electrical automated systems.
- The choice between the NO or NC function is made during wiring.

P_{12/9}

PSE 100 P

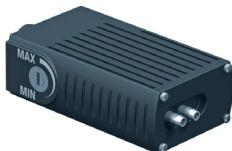

Pneumatic Vacuum Switch

- 2 versions available (NO or NC)
- Adjustment range: -300mb to -850mb
- The PSE 100 E series vacuum switch with pneumatic output enables the vacuum level in the system to be checked by means of a patented system.

- This vacuum switch exists in two versions:
- NO version, recommended for "air-saving" on the vacuum pump
- N.C. version to cover the "safety" function (object detected, etc.) and "SFC signal" function.

P_{12/10}

Vacuum Switch Range

Chapter 12

PSE 100 PK



Pneumatic Vacuum Switch

- 2 versions available (NO or NC)
- Adjustment range:
 - NC: -250 to -830mb
 - NO: -350 to -880mb
- The vacuum switch with pneumatic output is used to check the vacuum level in the circuit. It is recommended for measuring slowly changing vacuum levels such as regulating or checking vacuum levels in networks over 1 liter.
- NO version, recommended for "air-saving" on the vacuum pump.
- NC version to cover the "safety" function (object detected, etc.) and "SFC signal" function.

P 12/11

VAF 111



Needle Vacuum Gauge

- VAF 111 series vacuum gauges are recommended for viewing the level of vacuum on a network for maintenance, checking and adjustment purposes (Green zone of use: -0.65 to -1 bar)
- 3 diameters available: 40, 50 and 63 mm
- Zone for use printed red and green

P 12/12

PSK

Mini Vacuum Switch



The PSK series adjustable vacuum switches, due to a compact and ultra-light design, enable installation close to the suction cups for reduced response times. PSKs are ideal for applications requiring only a simple "object gripped" signal, and offer an economical and effective solution for applications with one vacuum generator per suction cup.

- Simple installation, plug-in port or thread-in fitting
- Compact size : 26 x 10 x 10.4 mm
- Weight: 8.3 g

Industry-specific applications

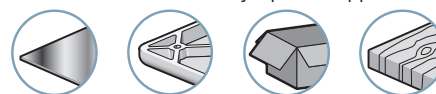

Specifications

Model	PSK 100
Setting pressure range	0 to 100% vacuum (0~-101.3 kPa)
Withstand pressure	0.6 MPa
Fluid	Air, Non-corrosive/Non-flammable gas
Power supply voltage	10.8 to 30 VCC
Load current	80mA max.
Internal voltage drop	≤ 0.8 V
Current consumption	10 mA max.
Sensor type	PNP
Output short circuit protection	Yes
Setting method	Adjusting by VR
Response time	Approx. 1ms
Repeatability	≤ +/-1% F/S/
Hysteresis	3% F.S. max.
Indicator	Red LED turns ON
Enclosure	IP 40
Temperature characteristic	≤ +/-3% F/S/ of detected pressure (25°C) at temp. Range of 0-50°C
Ambient temp. range	Operation : 0 ~ 60°C (32 ~ 140°F), Storage : -20 ~ 70°C (-4 ~ 158°F) (No condensation or freezing)
Ambient humidity range	Operation/Storage: 35 85% RH (No condensation)
Vibration	Total amplitude 1.5 mm, 10Hz-55Hz-10Hz scan for 1 minute, two hours each direction of X, Y and Z
Shock	980m/s ² (100G), 3 times each in direction of X, Y and Z
vacuum connection	Push-in tube or thread-in
Electrical connection	M8 connection 3-pin (Cable L:150 mm)
Weight	Approx. 8.3 g (with M8, 3-pin male connector)

Advantages

- Simple installation:
Plug-in port for push-to-connect fittings
- Compact size:
Extremely compact size to fit the most confined areas

Additional Information

Electrical connections

- M8, 3-pin male connector

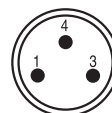

- 1 = + (Brown)
- 3 = - (Blue)
- 4 = out (Black)

- Ø6mm stem for one-touch push fitting, Male M5 or G1/8"-M.

Dimensions

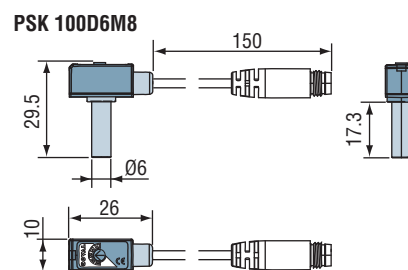
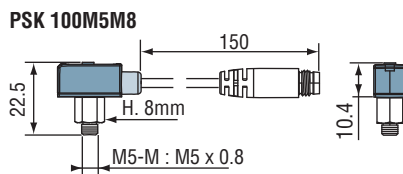
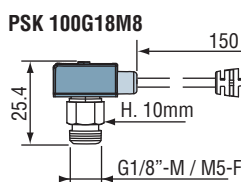

For all orders, please specify:
Model + Measuring range + Vacuum connection + Connection
 Example: PSK100G18M8

1: I	2: Measuring range	3: Vacuum connection	4: Connection
PSK	100 0 to 100% vacuum	D6 Ø 6 mm G18 G 1/8"-M, M5-F M5 M5 male	M8 M8, 3-pin male connector

PSA 100 C

Electronic Vacuum Switch with Display



The PSA100C series electronic vacuum switch is the most efficient COVAL vacuum measuring component. It can be easily installed on all machines and robots, etc. thanks to its compact lightweight design.

Moreover it has a digital vacuum level display with two independently-adjustable digital outputs. Every aspect has been designed to make it easy to use.

Advantages: front panel programming, simplified adjustment and threshold locking, display inversion, your choice of NO or N.C. outlets (hysteresis can be independently adjusted for each output).

Industry-specific applications

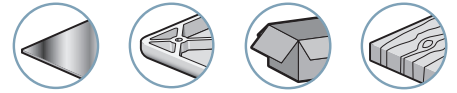

Specifications

Compatible fluids	All non-corrosive, filtered, non-lubricated gases
Supply	12 to 24 V CC ± 10%
Current consumed	≤ 60 mA
PNP transistor output	125 mA with 24 V DC, programmable NO or NC
Output viewing	Led
Output 1	Green LED
Output 2	Red LED
Programming	Keyboard
Display	Bar
EMC	Industrial standard Class B
Protection	IP 40
Electrical connection	M8, 4-pin connector
Pneumatic connection	G1/8" or M5-F
Shock resistance	100 G on XYZ
Display resolution	1%
Adjustment resolution	1%
Rating range	0.10 ~ -1.00 bar
Setting range	0.00 ~ -1.00 bar
Maximum overpressure	3 bar
Weight	30 g

Advantages

- 2 configurable digital outputs
- Adjustable hysteresis
- M8 F connector
- LED display
- PNP

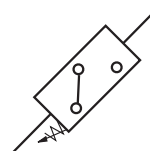

Additional Information

Electrical connections

- M8 connector

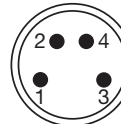

- 1 = + 24 V DC
- 2 = Output 2
- 3 = Common
- 4 = Output 1

Dimensions

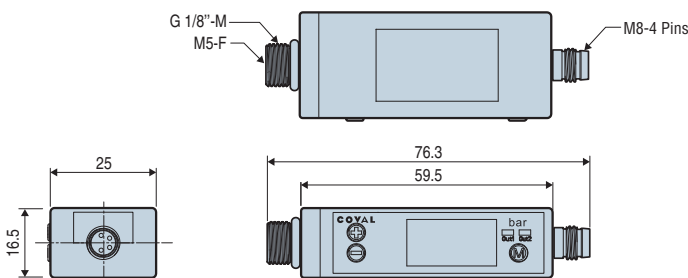

Accessories

- Straight or elbow connector, see page 11/12.
- Mounting on vacuum pump:
 - GVP series: GVO PSA 100 C
 - GEMP series: VA option

Note: all dimensions shown in (mm)



For all orders, please specify: PSA 100 C

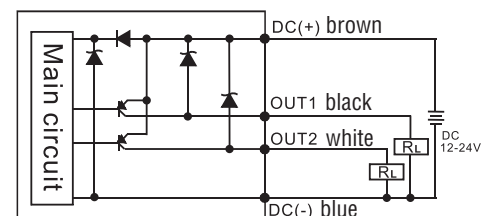

PSD 100

Vacuum Switch with 3-color Display



The new PSD100 series mini-vacuum switch with display offers easy reading thanks to the size of its screen and its 3-color display.

Its compactness and lightness facilitate its integration on all machines. Easily adjustable, it is equipped with an extremely precise electronic vacuum level sensor and has an adjustable digital output as well as an analog output. The PSD100 has mounting accessories on option, making it very easy to install.

Industry-specific applications

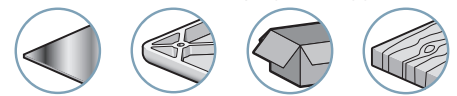

Specifications		
Pressure rating range	0.0 ~ -101.3 kPa	
Pressure setting range	10.0 ~ -101.3 kPa	
Max. pressure	300 kPa	
Fluid	Air, non-corrosive/non-flammable gas	
Pressure setting resolution	kPa: 0.1 MPa: / kgf/cm ² : 0.001 bar: 0.001 psi: 0.01 inHg: 0.1 mmHg: 1	
Power supply voltage	12 to 24 V DC ±10%, ripple (P-P) 10% or less	
Current consumption	≤ 40 mA (without load)	
Switch output	1 PNP digital output (2x on PNP2 version) Max. load current: 125 mA Max. supply voltage: 24 VDC Residual voltage: ≤ 1.5 V	
Repeatability (Switch output)	≤ ± 0.2% F.S. ±1 digit	
Hysteresis	Threshold mode	Adjustable (1 to 8 digits)
	Hysteresis mode	Adjustable
	Window comparator mode	Adjustable (1 to 8 digits)
Response time	≤ 2.5ms (anti-vibration function: 25 ms, 100 ms, 250 ms, 500 ms, 1000 ms and 1500 ms selection)	
Output short circuit protection	Yes	
7 segment LCD display	Two colour (red / green) main display, orange sub-display (refresh rate: 5 times / 1sec.)	
Indicator accuracy	≤ ± 2% F.S. ± 1 digit (ambient temperature: 25 ± 3°C)	
Switch ON indicator	Orange OUT 1 / OUT 2 (PNP2 only)	
Analog output (voltage power) (PNP version only)	Output voltage: 1 to 5 V ≤ ± 2.5% F.S. (within rated pressure range), linearity: ≤ ± 1% F.S. / Output impedance: approx. 1 kΩ	
Environment	Enclosure	IP40
	Ambient temp. range	operation: 0 – 50° C / storage: -10 – 60° C (no condensation or freezing)
	Ambient humidity	Operation / Storage: 35-85% RH (no condensation)
	Permissible voltage	1000 V AC in 1-min (between case and lead wire)
	Insulation resistance	50 M Ohm min. (at 500 V DC, between case and lead wire)
	Vibrations	Total amplitude 1.5 mm or 10 G, 10 Hz-150 Hz-10 Hz scan for 1 minute, two hours in each direction of X, Y and Z
	Shocks	100 m/s ² (10 G), 3 times each in direction of X, Y and Z
Temperature characteristic	≤ ± 2% F.S. of detected pressure (25°C) at temp. range of 0~50°C	
Port size	G1/8", M5-F	
Lead wire	Oil-resistance cable (0.15 mm ²)	
Weight	Approx. 45 g (with M8, 4-pin male connector)	

Advantages

- 3-colour digital LCD display, easy readability.
- 6 pressure units available (kPa, bar, psi, inHg, mmHg, kgf/cm²).
- PNP version:
 - 1 PNP digital output (NO or NC).
 - 1 analog output (1-5V).
- PNP2 version:
 - 2 PNP digital outputs (NO or NC).
- Double display showing the measured value and threshold value at the same time.
- "Key lock function" with indicator light, «Lock» mode with light indicator to prevent an accidental misadjustment.
- "Power-save function" with indicator light.
- 3 mounting solutions.

Panel Description

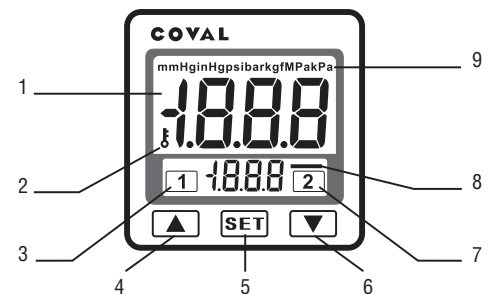

- 1 - 2-colour main display
- 2 - Lock indicator
- 3 - Output 1 indicator
- 4 - Button
- 5 - Setting button
- 6 - Button
- 7 - Output 2 indicator (PNP2 version)
- 8 - Setting mode (sub-display section)
- 9 - Pressure unit display section



PSD 100



For all orders, please specify:
Model.
Example: PSD100CPNP

1: Model	2: Electrical connection	3: Outputs
PSD100CPNP	M8 connector	1 digital output PNP 1 analog output
PSD100LPNP2	2 m cable	2 digital outputs PNP

Accessories

- CDM8: M8 Female connector – 4 poles, 2 m.
- PSDFIXA: Vertical attachment bracket.
- PSDFIXB: Horizontal attachment bracket.
- PSDFIXC: Front attachment kit.
- PSDFIXD: Front attachment kit + front protective lid.

PSD 100

Vacuum Switch with 3-color Display



Electrical connections - Dimensions

■ M8 Connector-4 poles

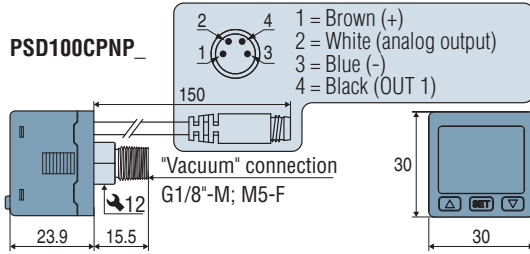

■ 2 m. cable

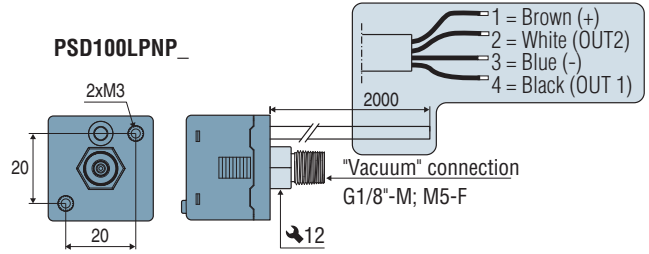

Electrical Diagrams

PSD100_PNP

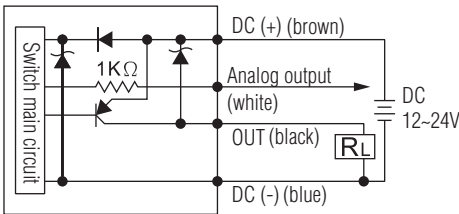

PSD100_PNP2

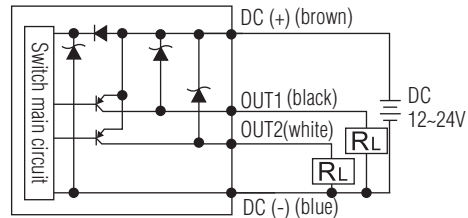

Mounting Solutions

Mounting brackets

■ PSDFIXA, vertical attachment.

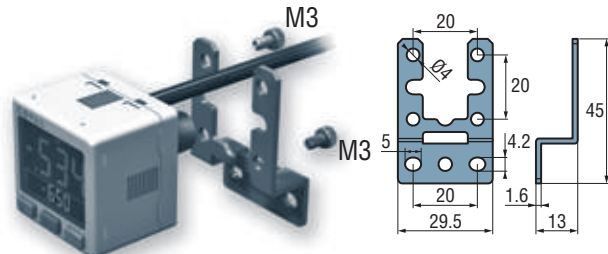

■ PSDFIXB, horizontal attachment.

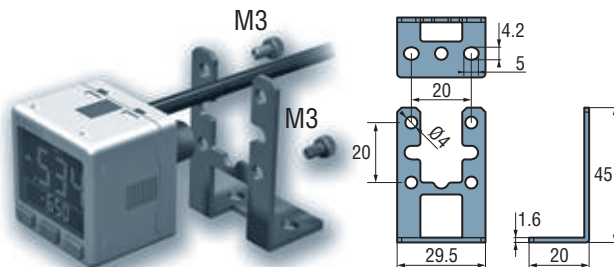

Panel mounting kits

■ PSDFIXC: front attachment kit.

■ PSDFIXD: front attachment kit + front protective lid

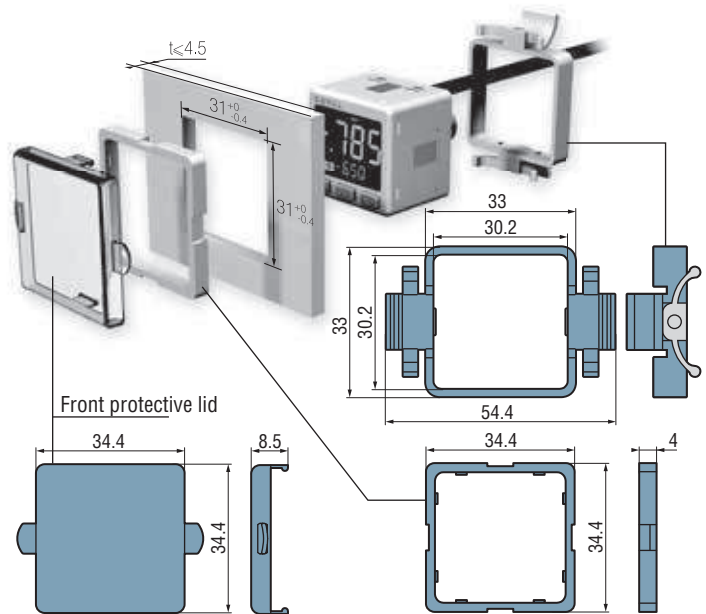

Panel opening (max. thickness: 4.5 mm)

For 1 vacuum switch

For multiple vacuum switches:

$A = (34.4 \times n) - 3.4$

Dimensions after installation

$n = \text{number of switches}$

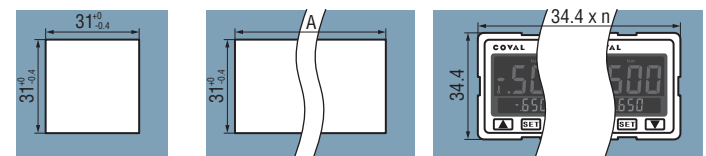

Note: all dimensions shown in (mm)

PSP 100 CX

Electronic Vacuum Switch

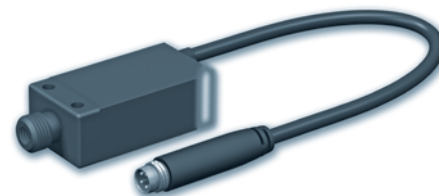

The electronic vacuum switch PSP100CX integrates standard threshold and hysteresis adjustment. It is equipped with two vacuum connections (G1/8"-Male, M5-Female) and an M8 connector 4-pin for electrical connection.

Industry-specific application

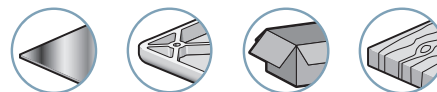

Specification

Models	PSP100CX
Compatible fluid	All non-corrosive, filtered, non-lubricated gases
Supply	Regulated 12-24 V DC, polarity inversion protection
Current consumed	< 21 mA
Transistor output	NO 80 mA with 24 VDC
Thermal drift	± 3% of the measuring scale between 0 and 50°C / 32 and 122°F
Output viewing	LED
Response time	< 5 ms
Threshold adjustment	By 3/4 turn potentiometer
Hysteresis adjustment	0 to 10% adjustment by 3/4 turn potentiometer
EMC	Industrial standard class B
Materials	PA 66 and brass
Temperature	Operation: 0 to 50 °C / 32 to 122 °F Storage: -20 to 60 °C / -4 to 140 °F
Protection	IP 40
Electrical connection	M8 connector 4-pin (cable length: 0.3 m)
Pneumatic connection	G1/8"-M or M5-F
Weight	22 g
Adjustment range	0 to -1 bar

Advantages

- 1 adjustable digital output
- Adjustable hysteresis
- Measuring range: 0 / -1 bar
- Overpressure: +3 bar
- PNP

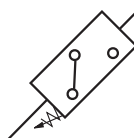

Dimensions

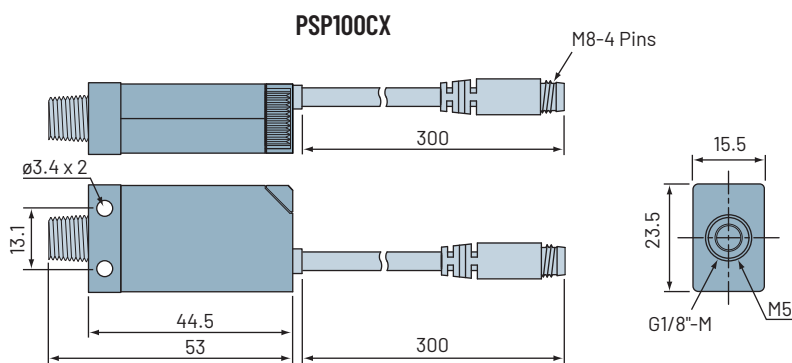

- (1) Hysteresis adjustment
(2) Threshold adjustment
(3) Threshold display LED

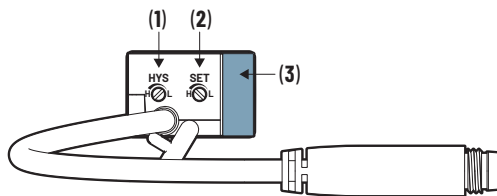

Additional Information

Electrical connections

- M8 connector 4-pin (cable length: 0.3 m)



- 1 = + 24 V - Brown
2 = -
3 = 0 V - Blue
4 - Contact - Black

Accessories

- Vacuum switch attachment - Clip Part No: PSEF

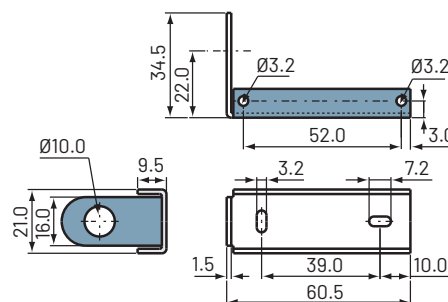

Accessories

- Straight or angled connector, see page 11/12.
- Mounting on vacuum pump:
 - GVP series: GVOPSP100CX
 - GEMP series: VB option

Note: all dimensions shown in (mm)



For all orders, please specify: PSP100CX

PSP 100 ANA

Electronic Vacuum Switch Analog Output



The PSP 100 ANA contains an analog output. It is fitted with 2 vacuum connections as standard (G1/8" male or M5 Female) and one M8 electrical connector.

Industry-specific applications

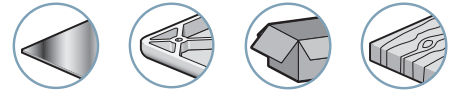

Specifications

Compatible fluids	All filtered, non-corrosive, non-lubricated gases
Supply	24 V DC (18 V DC min / 30 V DC max)
Current draw	< 20 mA
Analog output	1 to 5 VDC from 0 to -1 bar
Thermal drift	± 3% of the measuring scale between 0 and 50°C
Response time	< 5 ms
EMC	Industrial standard Class B
Materials	PA 66 and brass
Temperature	Operation: 0 to 50 °C / 32 to 122 °F Storage: -10 to 60 °C / 14 to 140 °F
Protection	IP 50
Electrical connection	M8 connector (4 pins)
Pneumatic connection	G1/8" Male and M5 Female
Weight	22 g

Advantages

- 1 analog output from 1 to 5 VDC
- Measuring range: 0 / -1 bar
- Overpressure: +3 bar max.
- PNP

Electrical connections

- M8 connector

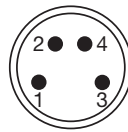

- 1 = + 24 V (Brown)
- 2 = analog output from 1 to 5 VDC (white)
- 3 = 0 V common (blue)
- 4 = -

Dimensions

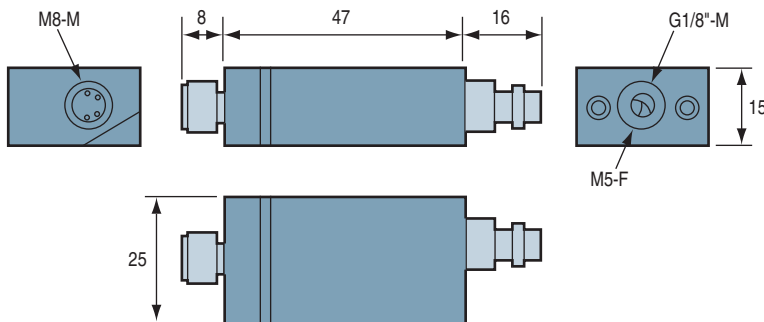

Note: all dimensions shown in (mm)

Accessories

- Straight or elbow connector, see page 11/12.



For all orders, please specify: PSP 100 ANA

PSE 100 P

Pneumatic Vacuum Switch



The PSE 100 P series vacuum switch with pneumatic output allows the vacuum level in the system to be checked by means of a patented system. This vacuum switch exists in two versions: NO version recommended for the "air saving" function on a venturi and NC version for the "safety" function (object detected, etc.) and "SFC signal".

Industry-specific applications

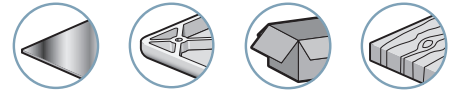

Specifications

Models	Two versions: NO and NC
Compatible fluids	All non-corrosive gases
Operating pressure	2 to 6 bar
Adjustment range	-400 mb to -800 mb
Precision	3%
Hysteresis	80 to 100 mb
Repetitivity	< 3% of the whole range
Maximum speed	30 cycles per minute
Permissible overpressure	2 bar (destructive at 5 bar)
Mechanical endurance	5 x 10 ⁶ operations
Materials	Body: Polyacetal - Vacuum sensor: nitrile membrane
Weight	32 g
Temperature	-10 °C to 80 °C / 14 °F to 176 °F
Flow rate at 6 bar	70 NI/min

Dimensions

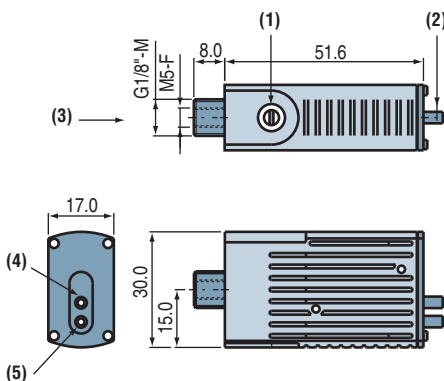

- (1) Vacuum threshold - Adjustment screw
- (2) Hollow shaft for tube, inside Ø 2.7 mm
- (3) Vacuum
- (4) NO or NC output
- (5) Pressure input

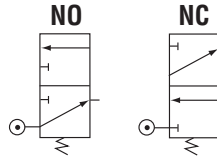

Additional Information

- Mounting as GVO option in the GVP / GEMP vacuum pump range.

Pneumatic connection

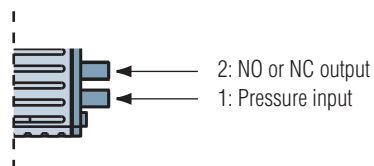

Vacuum switch attachment - Clip Part No: PSE.F

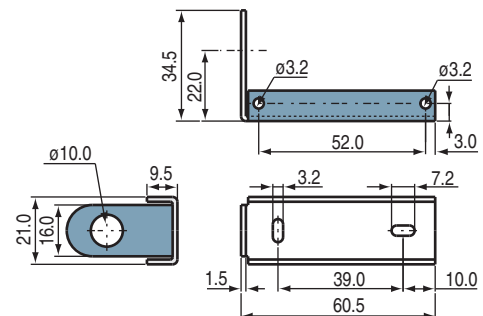

For all orders, please specify:
Model + Version.
Example: PSE100PNO

1: Model	2: Version
PSE 100 P	NO Normally Open (NO) NF Normally Closed (NC)

Note: all dimensions shown in (mm)

PSE 100 PK

Pneumatic Vacuum Switch



The PSE 100 K vacuum switch with pneumatic output is used to check the vacuum level in the circuit.

It is recommended for measuring slowly changing vacuum levels such as regulating or checking vacuum levels in networks over 1 liter.

This vacuum switch exists in two versions: NO version recommended for the "air saving" function on a venturi and NC version for the "safety" function (object detected, etc.) and "SFC signal".

Industry-specific applications

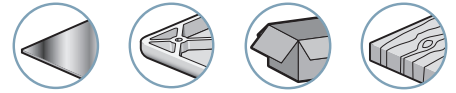

Specifications

Models	Two versions: NO and NC
Compatible fluids	All non-corrosive, non-lubricated gases
Operating pressure	2 to 6 bar
Adjustment range	NF: -250 to -830 mb, NO: -350 to -880 mb
Precision	± 10 %
Hysteresis	NF: 10 mb - NO: 200 mb
Repetitivity	< 3% of the whole range
Maximum speed	30 cycles per minute
Permissible overpressure	2 bar (destructive at 5 bar) (on vacuum measuring orifice)
Mechanical endurance	5 x 10 ⁶ operations
Materials	Body: Polyacetal - Vacuum sensor: nitrile membrane
Weight	32 g
Temperature	-10 °C to 80 °C / 14 °F to 176 °F
Flow rate at 6 bar	66 NI/min

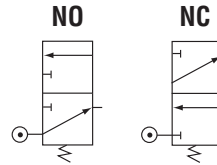

Dimensions

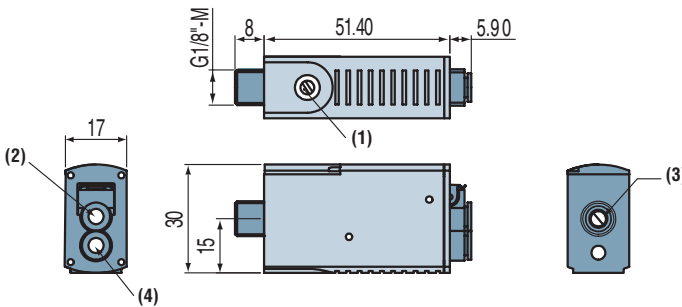

- (1) Vacuum threshold adjustment
- (2) Signal output, NC or NO tube
- (3) M5 Vacuum input
- (4) Pressure input Ø4 tube

Additional Information

- Mounting in GVO option in the GVP / GEMP vacuum pump range.

Pneumatic connection

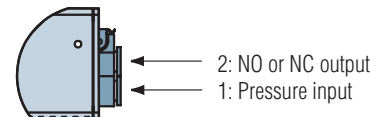

Vacuum switch attachment - Clip Part No: PSE.F

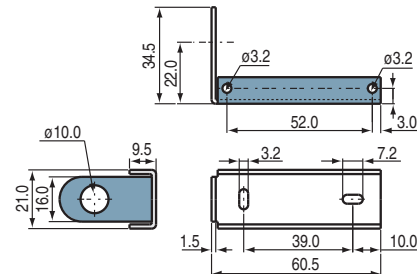

Note: all dimensions shown in (mm)

For all orders, please specify:
Model + Version.
Example: PSE100PKNO

1: Model	2: Version
PSE 100 PK	NO Normally Open (NO)
	NF Normally Closed (NC)

VAF 111

Vacuum Gauge



VAF 111 series vacuum gauges are recommended for visually checking the vacuum level for maintenance, monitoring and adjustment purposes.

They are mounted as options on modular vacuum pumps GVP series, reference GVO VAF11140.

See page 7/6.

Industry-specific applications

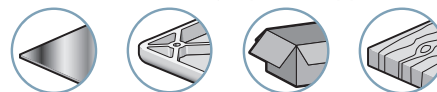

Characteristics

Models	D ⁽¹⁾	D1	b1	b2	b3	b4	d
VAF 111 40	40	43	32.5	12	52	4	G1/8"-M
VAF 111 50	50	54	32.5	12	52	4	G1/4"-M
VAF 111 63	63	68	32.5	12	52	4	G1/4"-M

(1) Flush-mounting diameter.
All dimensions shown in (mm)

Specifications

Damping	By silicone movement - Patented
Ring	Chrome
Measuring	Bourdon tube in CuSn
Precision	cl.2.5 (± 2.5% of max. scale value)
Housing	Black ABS
Temperature	0 to 60°C / 32 to 140°F
Flush-mounting	Ring included in the delivery
Option	as per quantity, possibility of customized dial.

Dimensions

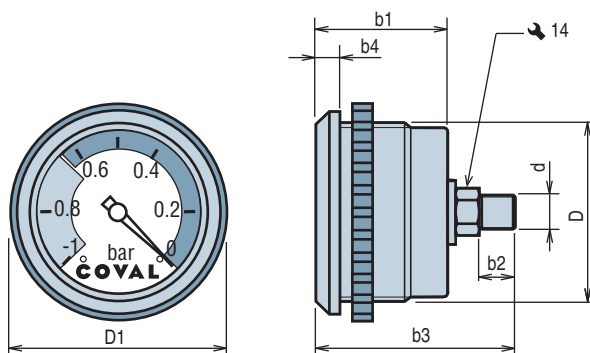

For all orders, please specify:
Model + Version.
Example: VAF11150

1: Model	2: Version
VAF 111	40 Ø 40 mm
	50 Ø 50 mm
	63 Ø 63 mm



Gripping Solutions

Chapter 13

CVGC



Carbon Vacuum Grippers for Collaborative Robots

- 3 standard formats (150x150, 240x120, 320x160 mm)
- Ultra-light and compact, due to their carbon design
- Foam gripping interface
- Plugin URCap
- Simple and efficient integration into collaborative robots
- Integrated Vacuum generator and vacuum switch
- Wide range of connections and gripping interface for a simplified installation

P 13/2

CVGL

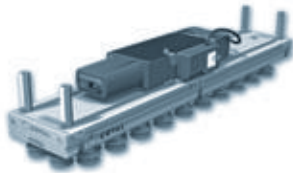

Compact and Light Vacuum Grippers

- 3 standard lengths (424, 624, 824 mm)
- Light and compact
- Configurable gripping interface (foam, suction cups, COVAL-flex)
- IO-Link and NFC communication interface
- Configurable following applications
- Random Gripping of various products
- Vacuum generators integrated or separated
- HMI as option
- Adaptable to all activity sectors

NFC))) IO-Link

P 13/6

MVG



Modular Vacuum Grippers

- Custom sizing from 150x150 to 1200x1000 mm
- Ultra-light
- Configurable gripping interface (foam, suction cups, COVAL-flex)
- Multi-zone
- IO-Link and NFC communication interface
- Thanks to their high degree of modularity, The MVGs vacuum grippers provide the optimal handling solution for products of varied sizes, shapes and weight,
- Staggered or multiple grip/release
- External or independant vacuum generation
- HMI as option
- Adaptation to all activity field

NFC))) IO-Link

P 13/24

CSGS



Bags/sacks Gripping System

- 2 suction cups sizes are available
- 2 lifting capacity: 35 and 60 kgs
- 4 suction power
- Robust and compact
- The CSGS is a complete assembly, suction cup + vacuum pump, for paper or plastic sacks handling of 25 to 60 kgs load
- Quick and economical installation

P 13/42



With their innovative design, Coval's **CVGC** carbon vacuum grippers correspond perfectly to the weight constraints, flexibility and safety of collaborative robot applications.

The **CVGC** series is composed of:

- a carbon structure, 2.5 times lighter than aluminum and offering mechanical strength 6 times greater
- flexible material on the gripper edges, to protect both gripper and operator
- foam gripping interface, for versatile product handling
- a plastic "function" block, including vacuum generator, pilot control cartridge, silencer and vacuum switch...

... all this, in a very compact and ultralight design, guarantees a fast setup and easy integration on the robot.

The three standard formats allow you to choose your **CVGC** and ensure the handling of your loads: corrugate, plastics, metal/glass plates, etc.

Industry-specific applications

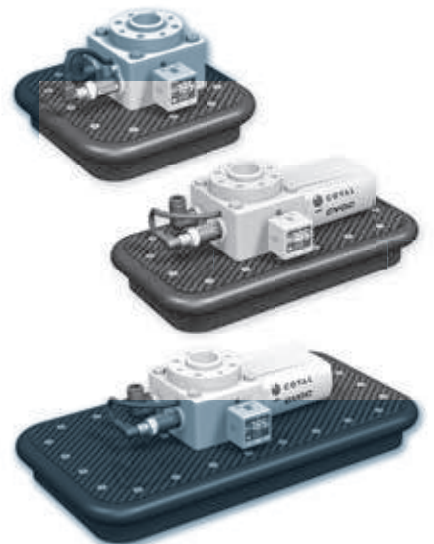
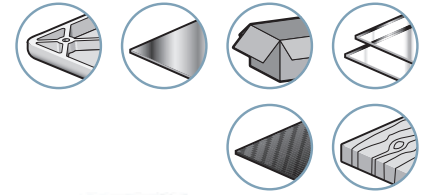

Advantages

- Ultra-light and compact, due to their carbon design.
- Suitable for collaborative robot applications, heavy-duty robots and special machines.
- Fully integrated, allowing for an easy and fast installation.

Characteristics

	Dimensions L x W x H (mm)	Air drawn in (NI/min)	Air consumed (NI/min)	Capacity ⁽¹⁾ (kg)	Weight ⁽²⁾ (kg)
CVGC 150X150	150 x 150 x 90	90	135	30	0.8
CVGC 240X120	240 x 120 x 90	180	270	38	1.0
CVGC 320X160	320 x 160 x 90	210	345	68	1.3

(1) Indicative force for a vacuum gripper with foam interface covered 100% by the load, including a safety factor of 2 for horizontal handling and rigid, airtight surface.

(2) Weight indicated for a gripper with A31 or A50 mounting. For a gripper with A63 mounting, add 136 g.

URCap plugin
available for e-Series robots



UNIVERSAL ROBOTS+
Certified

Applications

The **CVGC** vacuum gripper provide a unique solution for the handling of products in various industrial sectors:

- Packaging
- Plastics
- Metal
- Glass
- Composite
- Wood

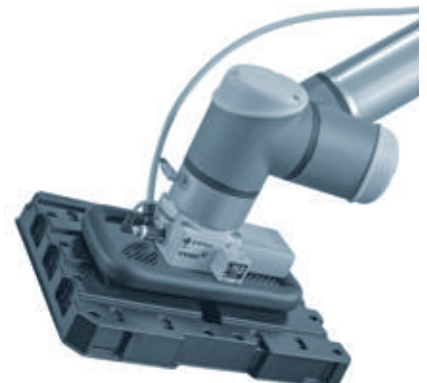



Ultra-light

Carbon design guarantees strength, rigidity and an unmatched lightness.



Vacuum Generator Integrated



3 Standard Formats

150 x 150 mm
240 x 120 mm
320 x 160 mm

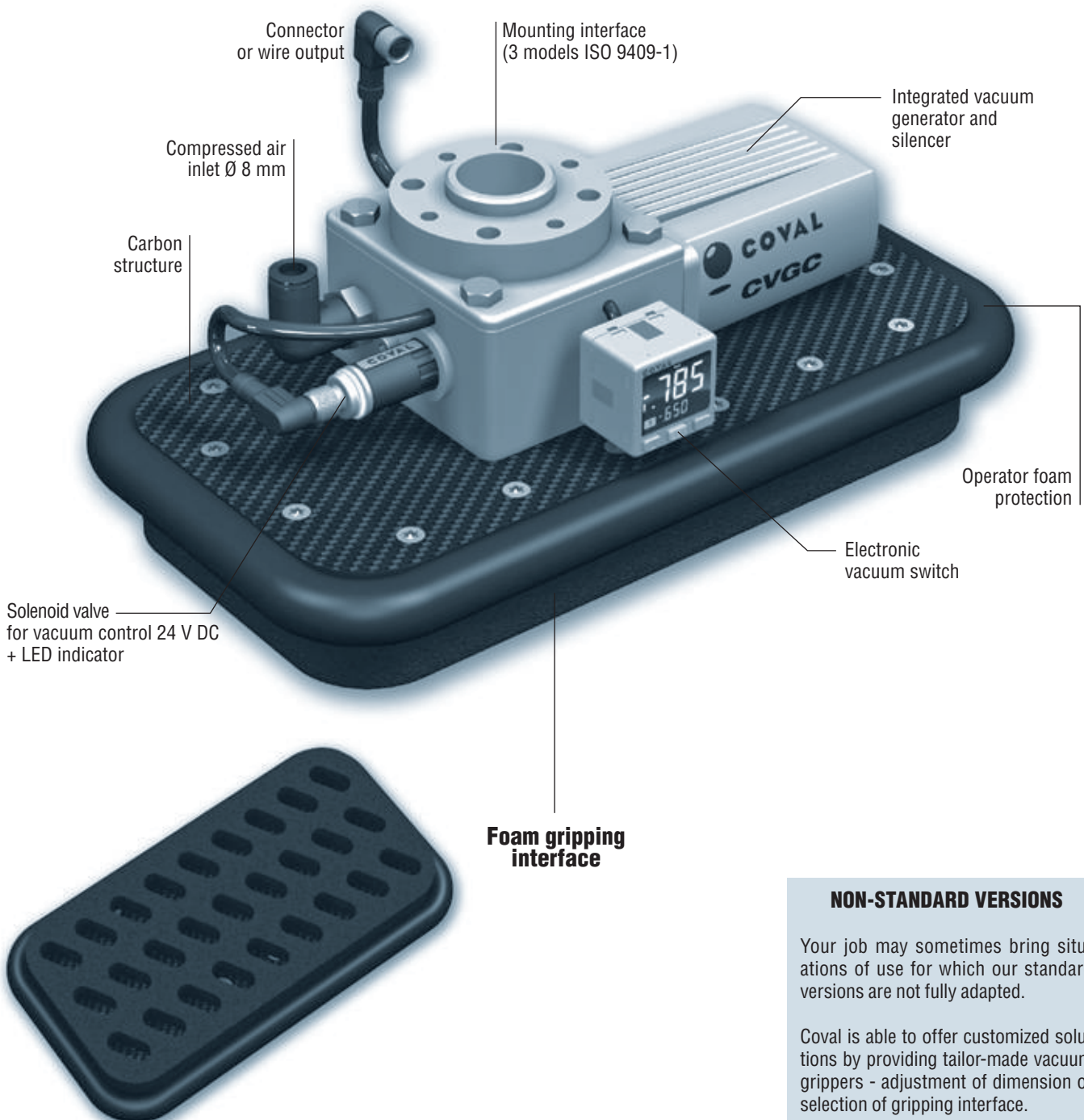

NON-STANDARD VERSIONS

Your job may sometimes bring situations of use for which our standard versions are not fully adapted.

Coval is able to offer customized solutions by providing tailor-made vacuum grippers - adjustment of dimension or selection of gripping interface.



To Order

	CVGC 240X120	A50	C1
DIMENSIONS		ISO 9409-1 ROBOT MOUNTING INTERFACE	ELECTRICAL CONNECTIONS
150 x 150 mm	150X150	A31 ISO 9409-1-31.5-4-M5	C1 M8 - Female 8-pins
240 x 120 mm	240X120	A50 ISO 9409-1-50-4-M6	C2 M8 - Male 5-pins
320 x 160 mm	320X160		C3 M8 - Male 8-pins
			C4 Wire outlet 2 m.
			C5 Wire outlet 5 m.
		A63 ISO 9409-1-63-4-M6	C6 Molex connector 8-pins

ISO 9409-1 Robot Mounting Interface

Version	Standard	Ø A (mm)	Ø B (mm)	Ø C (mm)	Ø D (mm)	
A31	ISO 9409-1-31.5-4-M5	31.5	40	M5 (4 screws)	5	Fanuc CR-4, CR-7, CR-7 A/L, CR-14 A/L
A50	ISO 9409-1-50-4-M6	50	63	M6 (4 screws)	6	Universal Robots UR3, UR5, UR10, UR16 + e-Series Omron/Techman TM5, TM12, TM14 Doosan Robotics A0509, A0509S, A0912, A0912S, M0609, M0617, M1013, M1509, H2017, H2515 Fanuc CRX10-iA
A63	ISO 9409-1-63-4-M6	63	80	M6 (4 screws)	6	Yaskawa HC10, HC10DT

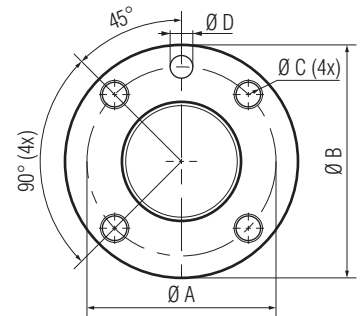

Electrical Connections

■ **C1:** M8 connector - female 8-pins elbow, cable length 150 mm

Universal Robots CB3 UR3, UR5, UR10 + e-Series UR3e, UR5e, UR10e, UR16e (URCap plugin available) / Fanuc CRX10-iA

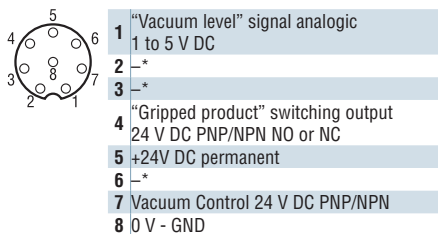

* not used in this configuration

■ **C2:** M8 connector - male 5-pins elbow, cable length 150 mm

Omron/Techman TM5, TM12, TM14

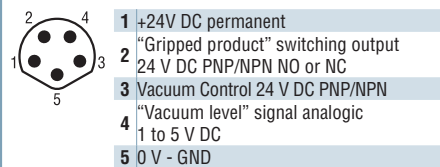

■ **C3:** M8 connector - male 8-pins elbow, cable length 150 mm

Doosan Robotics A0509*, A0509S*, A0912*, A0912S*, M0609, M0617, M1013, M1509, H2017, H2515
** Robots manufactured since 21-JAN-2021*

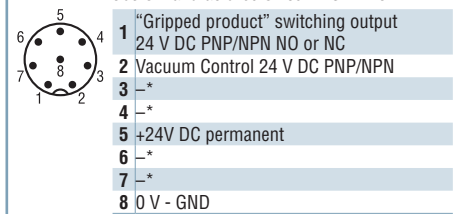

* not used in this configuration

■ **C4 / C5:** 5-wire output, cable length 2 m (C4) or 5 m (C5)

Fanuc CR-4, CR-7, CR-7, CR-7 A/L, CR-14 A/L + any application requiring cables to be routed outside the robot arm + any robot whose housing connection does not match C1/C2/C3/C6.

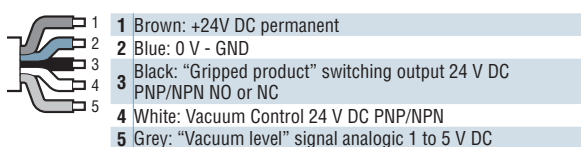

■ **C6:** Molex 8-pole connector, 50 mm long cable.

Yaskawa HC10, HC10DT (+ analog I/O card if required).

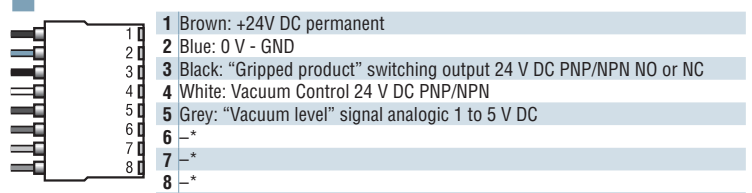

* not used in this configuration



Dimensions

CVGC150X150A

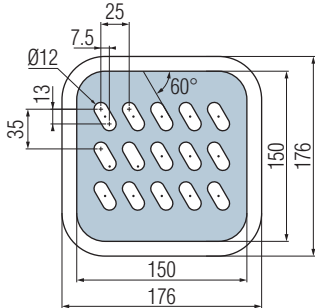

CVGC240X120A

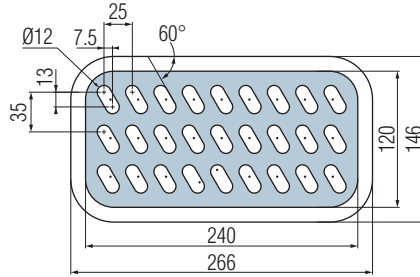

CVGC320X160A

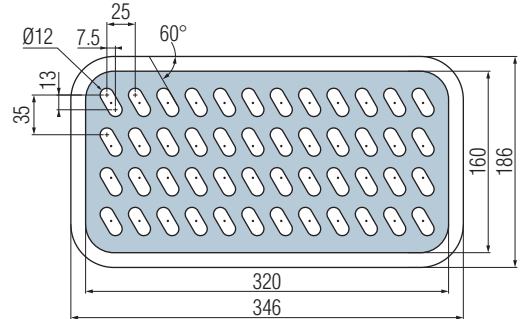

Mounting interfaces A31 or A50

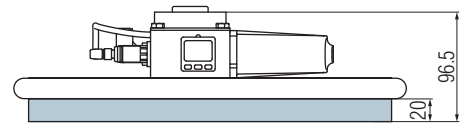
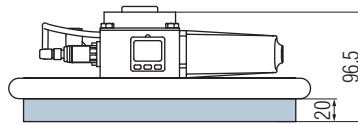
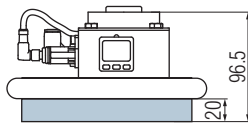

Mounting interface A63

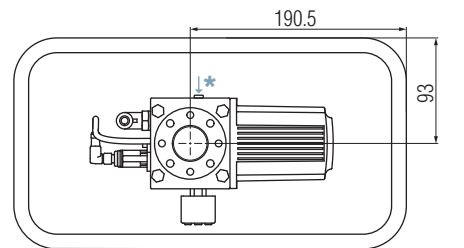
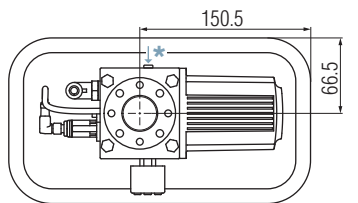
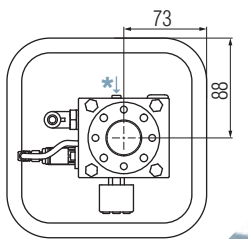
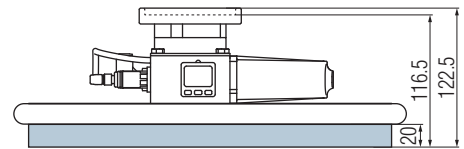
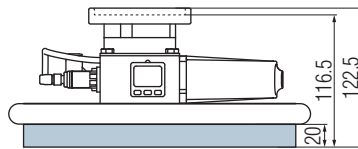
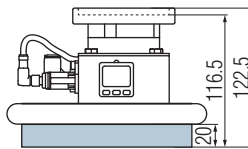

* M5 connection for external blow-off (M5 connector)

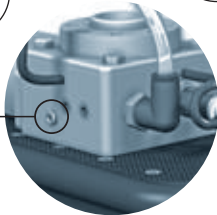

Note: All dimensions are in mm.

General Characteristics

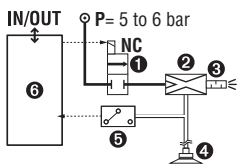

- 1 "Vacuum" solenoid valve
- 2 Venturi
- 3 Through-type silencer
- 4 Foam gripping interface
- 5 Electronic vacuum switch
- 6 Input / Output board

- Supply: non-lubricated air, 5 microns filtered, according to ISO 8573-1:2010 [4:5:4].
- Operating pressure: from 5 to 6 bar
- Optimal pressure:
 - CVGC 150x150 : 5.5 bar
 - CVGC 240x120 : 6 bar
 - CVGC 320x160 : 6.4 bar
- Maximum vacuum: 85%.
- Vacuum command light: orange LED
- Electric protection grade: IP40
- Control voltage: 24 V DC +/-10%
- Vacuum control: 24 V DC PNP/NPN

- Power consumption: 65 mA (no load)
- The switching type of the inputs / outputs is configurable to PNP or NPN
- Outputs:
 - 1 x "Vacuum level" signal analogic 1 to 5 V DC (depending on robot model, see "Electrical Connections" section)
 - 1 x "Gripped product" switching output 24 V DC PNP/NPN NO or NC (125 mA max.)
- Service life: 30 million cycles
- Operating temperature: from 0 to 50° C.
- Materials:
 - Gripper: carbon, PA 6.6 15% FG, brass, stainless steel, PETP.
 - Valve: aluminum, steel, NBR.
 - Foam gripping interface: EPDM.
- Noise level:
 - CVGC 150x150: 72 dBA
 - CVGC 240x120: 71 dBA
 - CVGC 320x160: 66 dBA

The values represent the average characteristics of our products.

CVGL

Compact and Light Vacuum Grippers

General Information

With the CVGL series, COVAL introduces a universal solution to the vacuum gripper that is flexible, simple, and economical.

Handling parts of various sizes, shapes, and weights is no longer a complex, costly, and time-consuming task.

With a single CVGL module easily integrated into the process, the user can simply and safely perform random gripping of assorted parts.

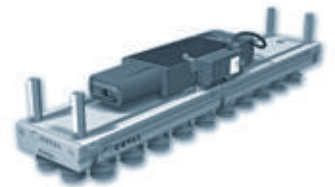

Industry-specific applications

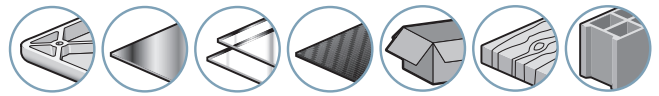

Advantages

The CVGL series is composed of standard subassemblies which allow COVAL to offer a tailor-made solution meeting the specific application requirements of integrators and end users:

- Compact
- Lightweight
- Integrated functions
- Communicating
- Modularity
- Performance
- Ease of use
- Universal mounting

A Complete System

Simply configure your CVGL vacuum gripper:

- 1 light and robust aluminum profile
- 1 universal mounting system
- 3 standard lengths (424, 624, 824mm)
- 3 suction levels
- 3 gripping interface technologies
- 3 standard hole/cup patterns
- 3 flow control technologies
- 2 control versions (vacuum and blow-off)
- 2 solutions for vacuum display
- + The Vacuum Manager experience of COVAL

= YOUR CVGL SOLUTION

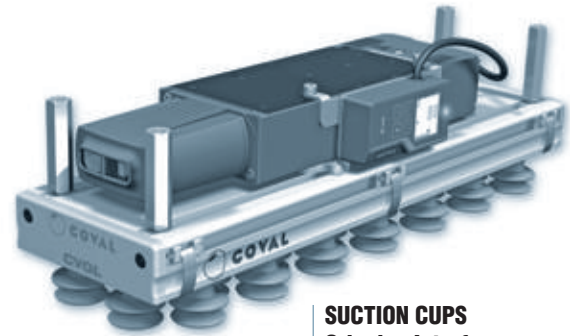

FOAM Gripping Interface

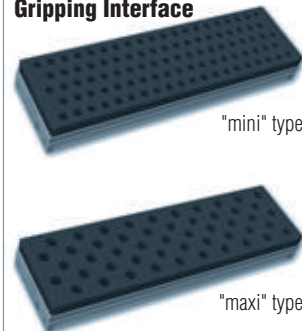

SUCTION CUPS Gripping Interface

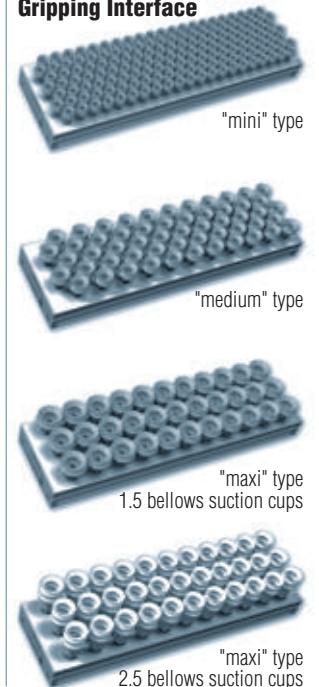

"COVAL-flex" Gripping Interface



Applications

The CVGL series vacuum grippers offer a single solution for the handling of products in multiple industrial sectors:

- Packaging
- Plastics
- Metal
- Glass
- Concrete/stone
- Composites
- Wood

The adaptability and the flexibility of COVAL CVGL Series vacuum grippers responds to numerous robotic applications.

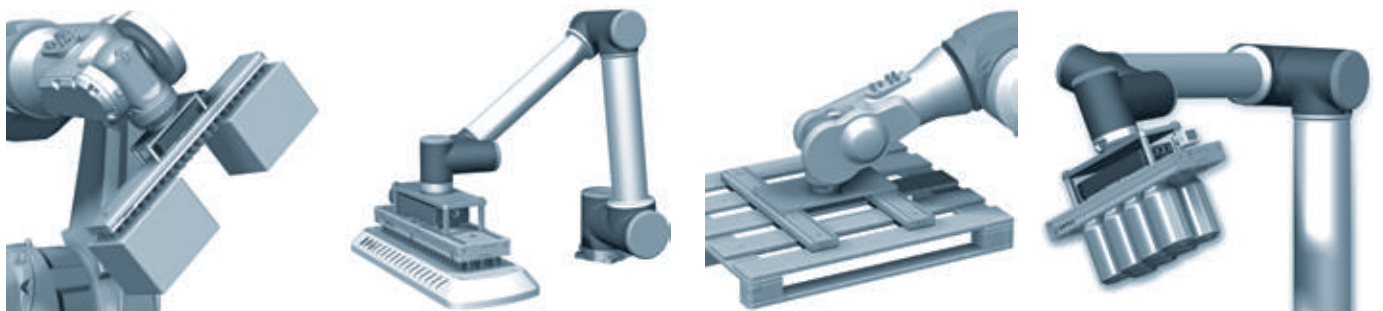

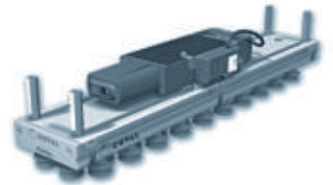

Modular Grippers



Ultra-light
Reduced payload weight



External or integrated vacuum generation



3 standard lengths
424, 624, and 824 mm



3 flow control technologies



Configurable gripping interface
depending on the products to be handled



Communication and Control

- Digital inputs/outputs (SIO)/IO-Link
- HMI
- NFC

G1"-F connection for external vacuum generator (electric or pneumatic)

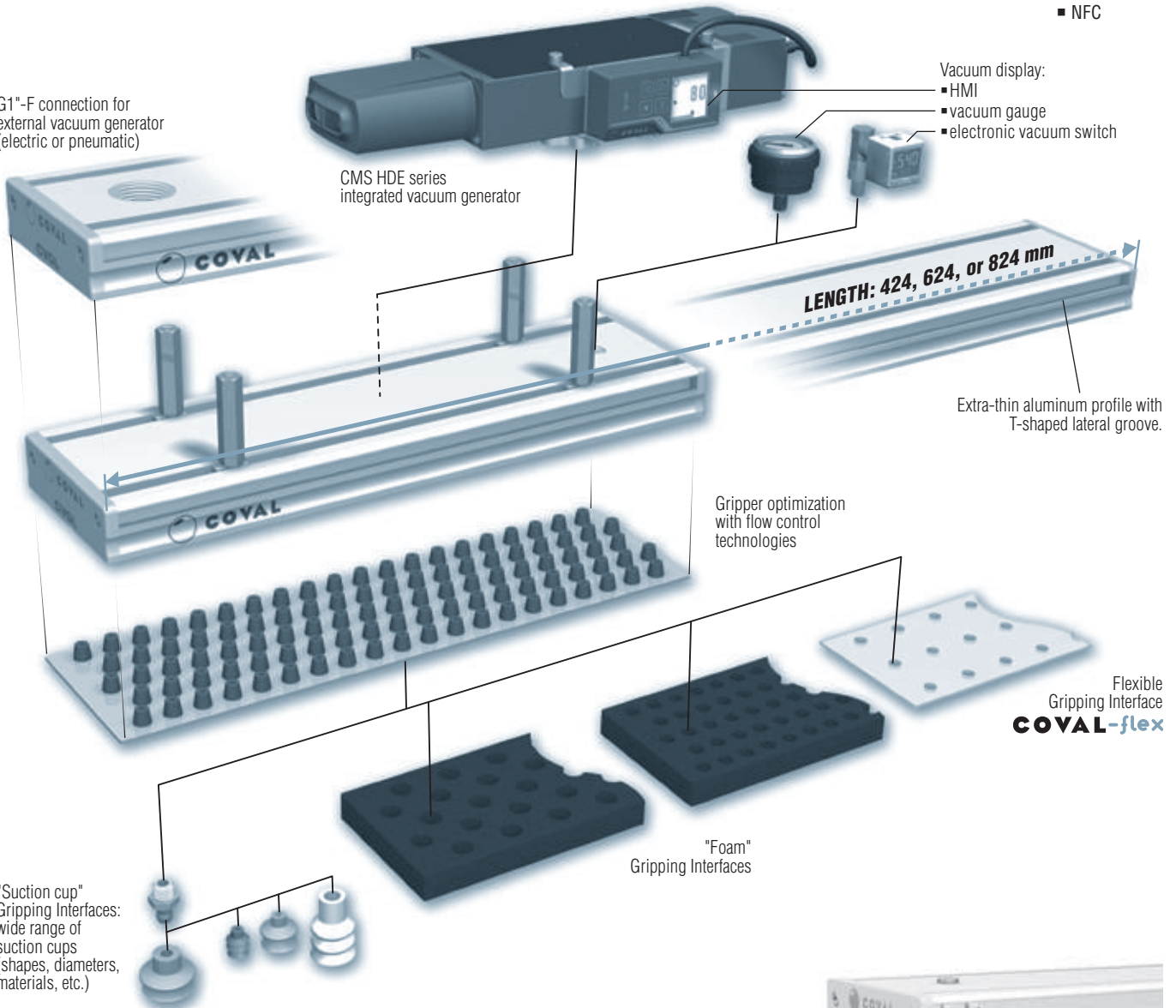

Gripper interface quick change system, ref: CVGL ___ C

To simplify maintenance and increase the flexibility of the CVGL series vacuum grippers, COVAL has developed an ultra-compact and easy-to-use solution for replacing the gripper interface. Very straightforward, the spring-loaded clips allow you to replace a worn or damaged gripper interface in a matter of seconds, or to install another type of interface (foam / suction cups / COVAL-flex).

Number of clips according to the length of the gripper:

- CVGL424: 6 clips.
- CVGL624: 8 clips.
- CVGL824: 10 clips.



CVGL

Compact and Light Vacuum Grippers

General Information

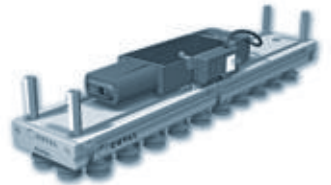

Multi-zone

CVGL vacuum grippers can create independent gripping zones, guaranteeing optimization of vacuum management (increased vacuum level, reduced leaks and energy consumption).

- Staggered grip/release points.
- Management of formats to be handled.
- Pallet Layer Optimization.
- Simple or multiple grip/release points.

As each multi-zone application is different, COVAL will work with you to determine the best configuration for your process.

Examples of configuration:

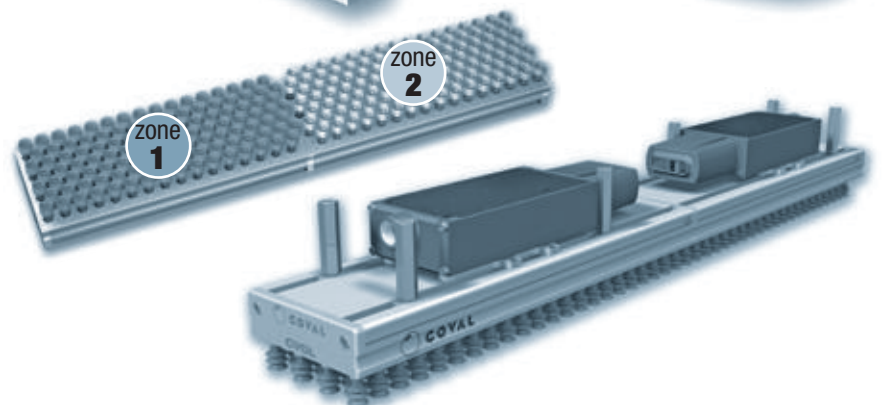
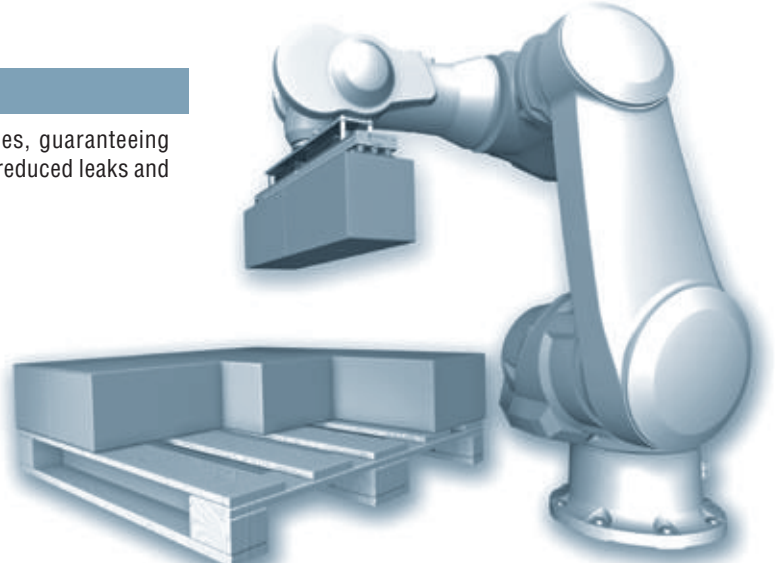
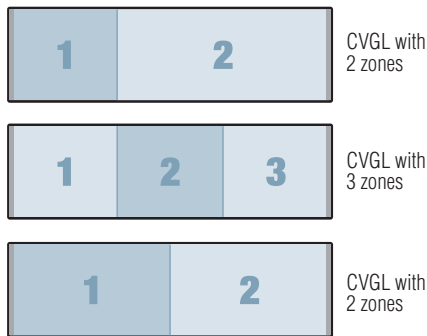

Ultra-light and compact design

The main design objective of the CVGL vacuum gripper is to minimize space and weight, while maintaining a highly modular configuration, to meet the needs of robotic applications.

Thanks to COVAL's aluminum profile, the CVGL vacuum grippers fully meet this objective. The ultra-thin profile allows for easy integration on robots.

The CVGL profile integrates the vacuum connections on the upper part, which provides greater compactness, as well as a T-slot on the side for mounting additional accessories such as sensors.

The technologies and materials used in the design of the CVGL vacuum gripper considerably reduce the on-board weight. This makes the CVGL the benchmark in its field, allowing smaller robots to be used, increasing accelerations and thus optimizing the installation in order to achieve savings.

Mass (in kg) depending on options

GRIPPING INTERFACE	Length (mm)	Vacuum gripper without vacuum generator (G0)	Vacuum gripper with 1 CMSHDE_50 vacuum generator (D1)		Vacuum gripper with 1 CMSHDE_100 vacuum generator (D2)		Vacuum gripper with 2 CMSHDE_100 vacuum generators (D3)
			without control	with control	without control	with control	without control
Foam Interface Mini F2S / Maxi F2B type with flow control nozzles (H version)	424	1.8	2.4	2.7	2.4	2.7	–
	624	2.6	–	–	3.2	3.5	–
	824	3.4	–	–	4.0	4.3	4.6
Foam Interface Mini F2S / Maxi F2B type with airtight or check valves (E and V versions)	424	2.0	2.6	2.9	2.6	2.9	–
	624	2.8	–	–	3.4	3.7	–
	824	3.7	–	–	4.3	4.6	4.9
Suction cup Interface Mini, Medium, or Maxi type with flow control nozzles (H version)	424	2.2	2.8	3.1	2.8	3.1	–
	624	3.2	–	–	3.8	4.1	–
	824	4.1	–	–	4.7	5.1	5.3

Average values shown

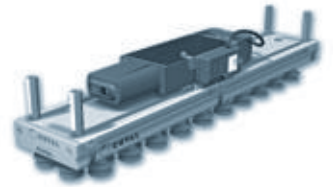

Choice of Gripping Interface

With CVGL, COVAL gives you a choice of 3 complementary gripping interface technologies: vacuum grippers with foam, suction cup grippers, and grippers with a COVAL-flex interface.

In order to optimize the performance of the CVGL series for different applications, the vacuum grippers are available in different gripping patterns, hole diameters, and cup sizes → A broad range which meets all application requirements.

"FOAM" Interface

- Handling of rigid products.
- Gripping textured or uneven surfaces.
- Flow control nozzles, airtight valves, or check valves.
- 2 standard hole diameters (Ø 12, 16mm).
- 2 standard hole patterns.
- 3 standard lengths (424, 624, and 824mm) or custom length.

"SUCTION CUP" Interface

- Handling of flexible products.
- Wide range of cup options.
- Flow control nozzles in multiple diameters.
- 4 types of standard suction cups (Ø 14, Ø 25, Ø 30 and Ø 33 mm).
- 3 standard cup patterns.
- 3 standard lengths (424, 624, and 824mm) or custom length.

"COVAL-flex" Interface

- Handling of aluminum cans, canned food, glass containers, etc.
- Flexible interface, extremely tear-resistant.
- Hole pattern dependent upon application requirements, completely customizable.

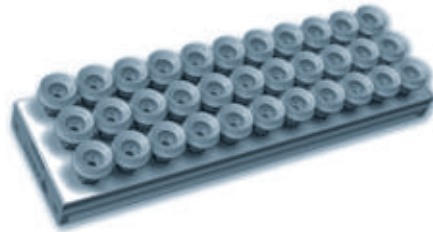
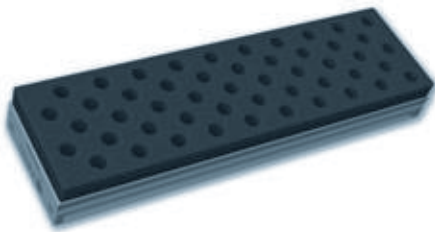

COVAL-flex

Standard Hole/Cup Patterns

In order to optimize the performance of the CVGL series for different applications, the vacuum grippers are available in different gripping patterns, hole diameters, and cup sizes.

"MINI" type

- Reduced hole spacing, allowing small, flexible pieces to be gripped.
- The multitude of gripping points guarantees a strong grip, even with random positioning of products.
- Dimensions, refer to page 18.

"MEDIUM" type

- An intermediate distribution of gripping points between the "mini" and "maxi" type.
- Ideal for handling dense loads with reduced gripping surface.
- Dimensions, refer to page 18.

"MAXI" type

- Large gripping point surfaces, allowing heavy loads to be gripped.
- Ideal for gripping parts with rigid gripping surfaces.
- Dimensions, refer to page 18.

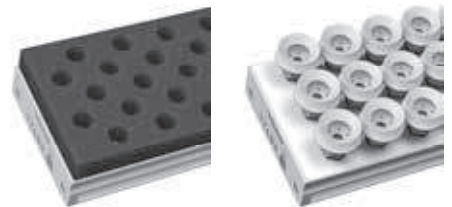
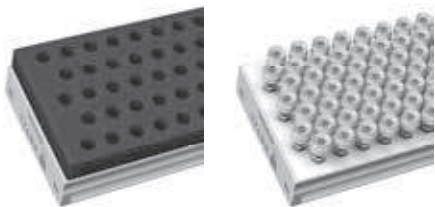

Vacuum Gripping Force

** Indicative force for a vacuum gripper 100% covered by the load, without safety factor, on a rigid and airtight surface.*

Part number	Total length of the vacuum gripper (mm)	Force at 80% vacuum (N)*	Force at 45% vacuum (N)*
CVGL 424_---	424	1035	600
CVGL 624_---	624	1550	900
CVGL 824_---	824	2070	1200

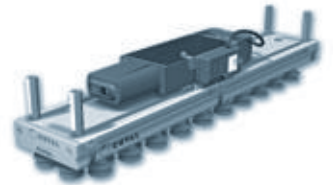

Flow Control Technologies

COVAL offers 3 flow control technologies to optimize your vacuum gripper and perfectly respond to the constraints of your application.

The COVAL vacuum management team will assist you in the selection and configuration of your CVGL vacuum gripper.

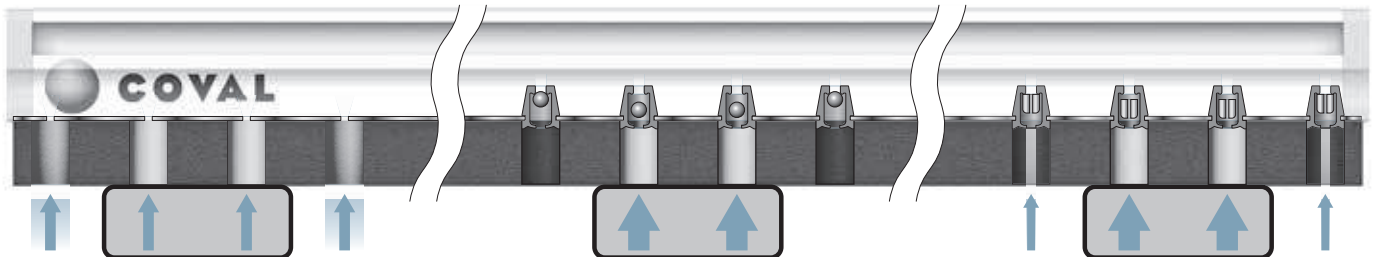

Flow control nozzles

- Limits the leakage rate of uncovered zones.
- Economic solution.
- Customizable calibration.
- Horizontal and vertical handling.

Airtight valves (COVAL patent)

- Isolates uncovered zones.
- Provides energy savings.
- Meets specific needs.
- Instant gripping.
- Quick release to blow-off.
- Horizontal handling.

Check valves (COVAL patent)

- Limits the leakage rate of uncovered zones.
- Instant gripping.
- High versatility of applications.
- Quick release to blow-off.
- Horizontal handling.

Vacuum Generation

Integrated vacuum generator, CMS HDE Series

Integration of a multi-stage vacuum generator on the CVGL gripper provides a comprehensive and compact gripping solution, as well as easy integration in your process.

Options: integration of a vacuum and/or blow-off solenoid control valve with M12 connector and a vacuum level display (electronic vacuum switch display or vacuum gauge), or HMI with LCD display.

Advantages:

- A comprehensive solution.
- 3 standard sizes.
- Option: vacuum and blow-off control valve.
- Option: visual display of vacuum level.
- Option: IO-Link communication interface.

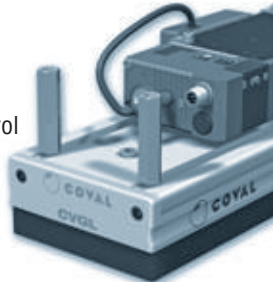

External vacuum generator

The CVGL vacuum grippers may also be used with an independent vacuum generator. Depending on the application, an external generator may be necessary (a blower, an electric vacuum pump or a pneumatic generator, CMS HD Series). The CVGL series vacuum gripper G0 version is equipped with a G1"-F flange allowing the vacuum source to be easily connected.

Option: integration of a vacuum level display (electronic vacuum switch display or vacuum gauge).

Advantages:

- Reduced weight.
- Adaptation to user environment.
- Option: visual display of vacuum level.

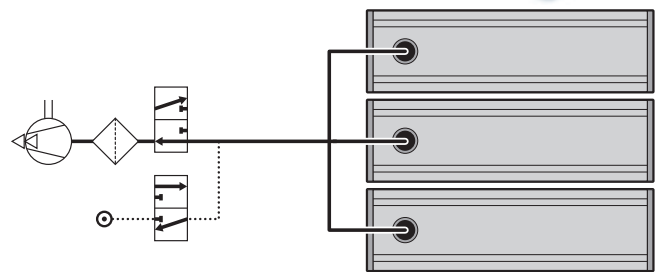
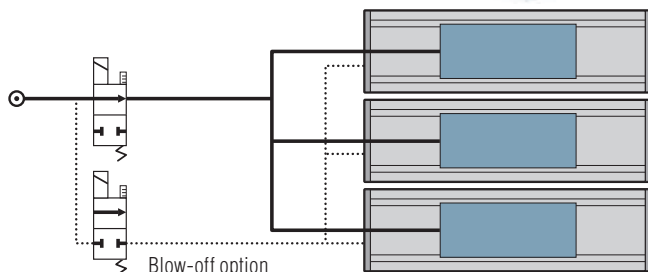
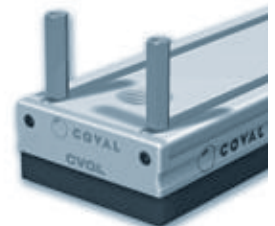

Technical data of the CMS HDE series integrated vacuum generators

Integrated vacuum generator	Model	Consumption (NI/min)	Flow rate (NI/min)	Max. vacuum (%)	Sound level (dBA)
CVGL___D1	CMSHDE_50	220	700	80	59
CVGL___D2	CMSHDE_100	420	1100	80	62
CVGL___D3	2xCMSHDE_100	840	2200	80	65

Generator configurations by vacuum gripper length

Vacuum generator	CVGL 424 _	CVGL 624 _	CVGL 824 _
G0	■	■	■
CMSHDE_50 (D1 Version)	■	-	-
CMSHDE_100 (D2 Version)	■	■	■
2xCMSHDE_100 (D3 Version)	-	-	■

CVGL

Compact and Light Vacuum Grippers Integrated Multi-stage Vacuum Pumps

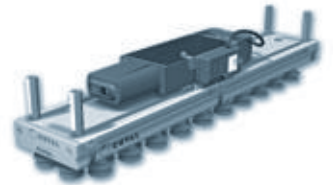

The CVGL vacuum grippers have a wide range of configurations with the CMS HDE Series multi-stage vacuum pumps, allowing for a specialized solution for each application.

CVGL__D_NOK

CMSHDE__NV0G4K multi-stage vacuum pump

- Without control.

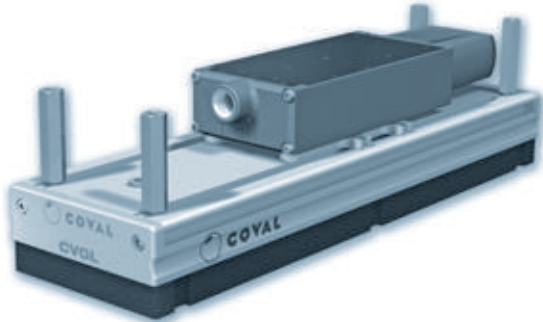

CVGL__D_S1 / V1K

CMSHDE__VOC15PG4K multi-stage vacuum pump

- With vacuum and blow-off control.
- Without vacuum switch.
- One M12 5-pin connector.
- Visual indicators of vacuum and blow-off controls.
- Digital inputs/outputs mode.

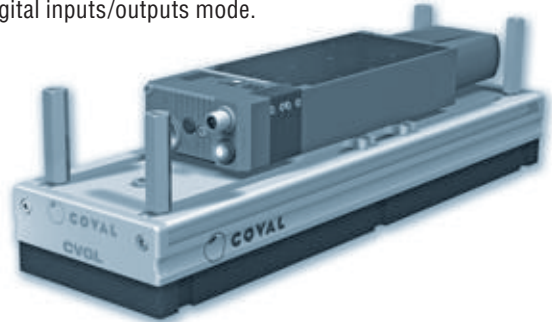

CVGL__D_S2 / V2K

CMSHDE__VXC15PG4KD multi-stage vacuum pump

- With vacuum and blow-off control.
- With vacuum switch, and pressure sensor.
- One M12 5-pin connector.
- One M8 4-pin connector for HMI (VI option).
- Digital inputs/outputs (SIO) / IO-Link Mode.



VI Version: Clear and efficient HMI: includes all required inputs for full operation of CMS HDE multi-stage vacuum pumps.

Gripping status indicator light (2 colors).

1.54" high-visibility color LCD display with clear multilingual messages and straightforward settings menu.

Settings keypad.



NFC)))

Straightforward setup and diagnostics made possible by NFC technology and COVAL Vacuum Manager mobile application.



Onboard installation and diagnostic tools:

- Clog detection.
- Supply pressure and voltage monitoring.

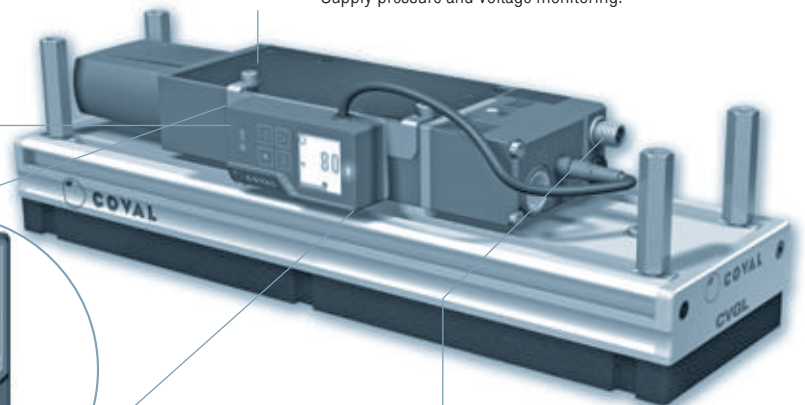

Digital inputs/outputs (SIO) / IO-Link

- M12 5-pin connector.

Modularity/Maintenance

The CMS HDE multi-stage vacuum pumps have been designed to withstand the demands from all your applications and to guarantee a high level of performance. However, handling certain parts may require replacement or cleaning.

The modular design of the CMS HDE multi-stage pumps ensures easy maintenance as the functions are all easily accessible.

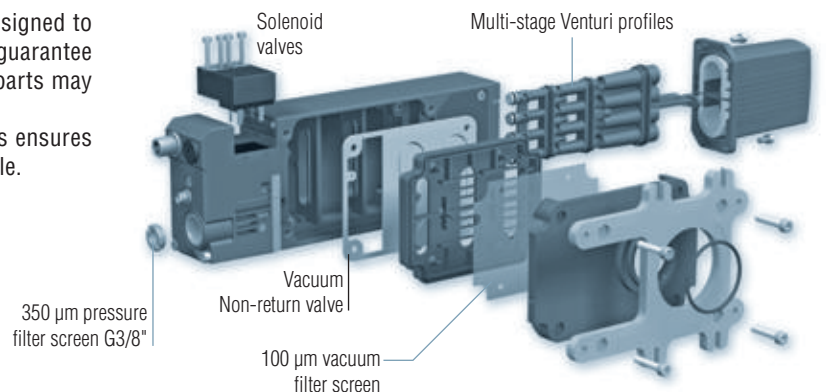

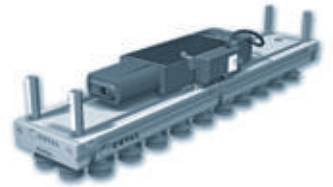

Easier Integration, Use, and Diagnostics

The **CMSHD__VX** Heavy Duty multi-stage vacuum pump series includes various features that enable setup, use, and diagnostics in all situations and at all levels (operators, process, networked

factory), with the aim in mind of keeping the use and management of the pumps as straightforward as possible and thus allowing for their easy integration in your smart factory.

Settings, Diagnostics, and Process Data



CONFIGURABLE SETTINGS

- Choice of language: EN, FR, DE, IT or ES.
- "Object gripped" thresholds.
- Automatic blow-off.
- Vacuum measurement unit: kPa, %, mbar, inHg.
- Pressure measurement unit: MPa, bar, psi.
- Software updates, and more.



DIAGNOSTICS

- Cycle counters (vacuum and blow-off control, objects gripped, objects lost, etc.).
- Vacuum network sizing support to prevent pressure loss.
- Clogging detection function.
- Supply pressure and voltage monitoring.
- Software version.
- Product part number and serial number.



PROCESS INPUT DATA

- Vacuum and blow-off control.



PROCESS OUTPUT DATA

- Instantaneous vacuum level.
- Object gripped and object lost information.
- Alarms (high/low pressure, high/low voltage).
- Instantaneous pressure.



IO-Link

The IO-Link system provides efficient real-time communication between **CMSHDE_VXC15X** multi-stage vacuum pumps and any higher-level protocol (EtherNet/IP, PROFINET, EtherCAT, etc.) required to monitor the production line. It can be used to control pumps, configure settings, and get feedback to ensure maximum productivity.

Advantages:

- Straightforward wiring, installation, and setup
- Availability of diagnostic status data
- Simpler preventive maintenance and vacuum pump replacement without manual setup, and more
- Onboard installation and diagnostic tools

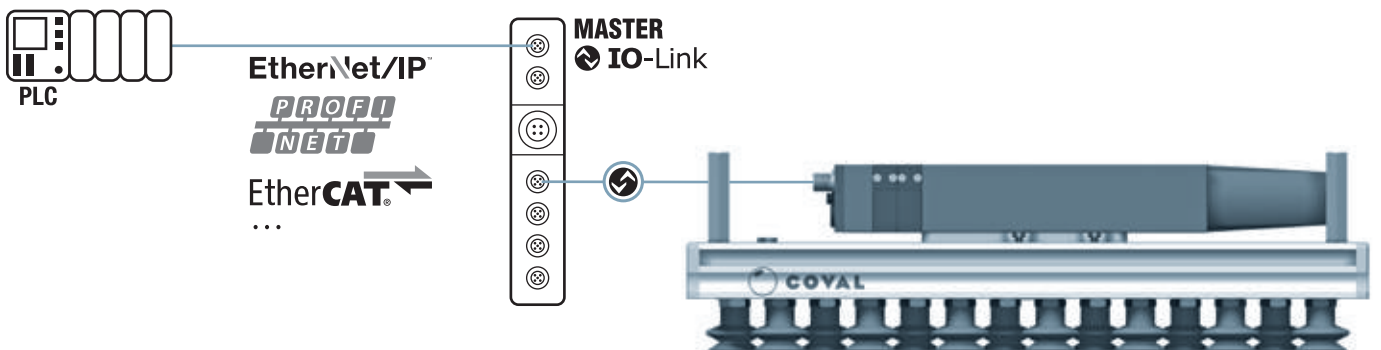

Compact and Light Vacuum Grippers Straightforward Communication

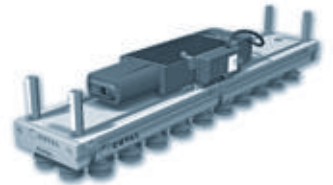

Mounted or Remote HMI

To facilitate the use and configuration of the vacuum generator, the CVGL range has an HMI that can be mounted on the generator or used remotely.

Advantages:

- Position the HMI on the vacuum generator or in an easily accessible and visible area.
- Use one HMI for multiple vacuum generators.
- Copy settings from one vacuum generator to the next.
- The vacuum generator will continue to operate with the HMI removed.

CVGL vacuum generators compatible with HMI:

→ CVGL__S2 / V2__ versions with M8 connector.

CVGL__VI version:

- HMI (ref: **HMIHD1M84P**) + mounting plate (**HMIHD1FIXC**) mounted on the vacuum generator.

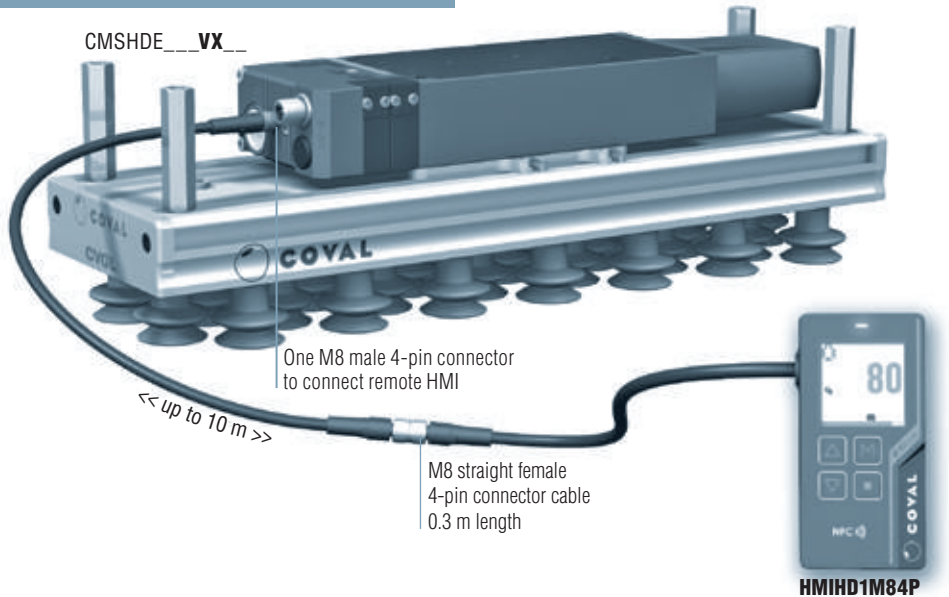
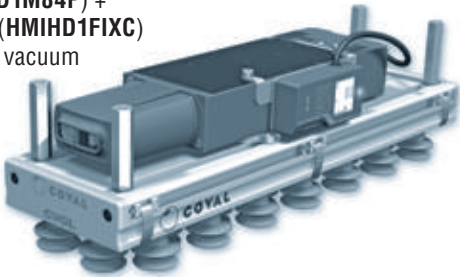

- Accessory: Remote HMI
- Ref: **HMIHD1M84P** (see accessories for HMI page 13/14).

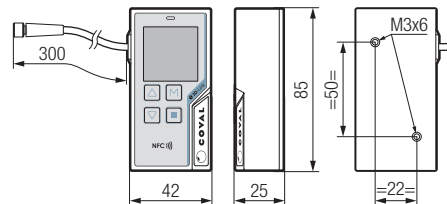

Note: all dimensions are in mm.

Remote HMI Dialog Front Panel



Gripping status indicator light:
 ■ Green: object gripped
 ■ Red: object lost

1.54" high-visibility color LCD display

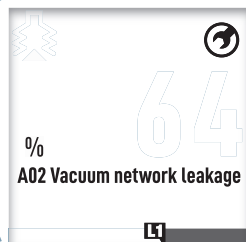

NFC antenna

Settings keypad

The HMI allows for a simple and efficient reading of the pump's operation. The high-visibility display includes all required inputs for full operation:

- Main information is easy to read
- Multilingual: EN - FR - DE - IT - ES
- Simple and clear event messages
- Intuitive settings and diagnostics menus
- Configurable display orientation: 0 - 90 - 180 - 270°
- Lockable to prevent undesired changes

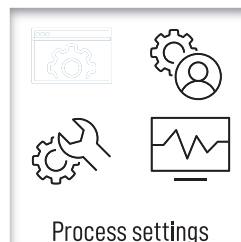

Multilingual

EN FR DE IT ES

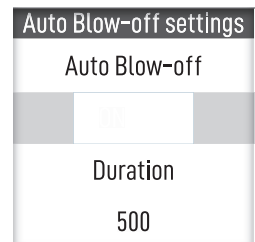

Compact and Light Vacuum Grippers Straightforward Communication

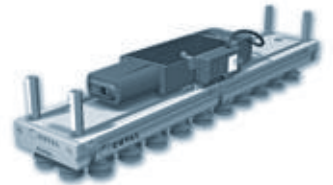

NFC)))

The NFC wireless technology integrated in remote HMI and in the COVAL Vacuum Manager application makes all setup and diagnostic functions available and modifiable on your mobile devices.

Additional features:

- Read/write settings with the power on or off.
- Copy settings from one CMS HD to another.
- Backup up to 5 setting configurations.
- COVAL support: send a report including the settings and diagnostic data to COVAL for technical support.



NFC APP: COVAL Vacuum Manager
Available for Android and iOS

Accessories for HMI

Front mounting plate
+ 2 x M3x6 TORX
+ 2 x M5x50 CHC
Part No.: **HMIHD1FIXA**

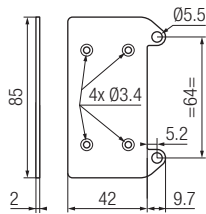

Side mounting plate
+ 2 x M3x6 TORX
+ 2 x M5x50 CHC
Part No.: **HMIHD1FIXC**

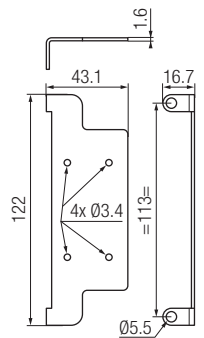
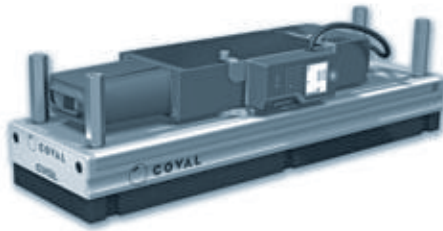

90° angled mounting plate
+ 2 x M3x6 TORX
Part No.: **HMIHD1FIXB**

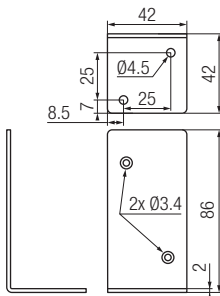

Connecting cable

M8 4-pin, female / M8 4-pin, male, compatible with cable chain

- 2 m length: Part No. **CDM8MF4PL2**
- 5 m length: Part No. **CDM8MF4PL5**
- Other lengths available upon request.



in mm, any versions

Note: all dimensions are in mm.

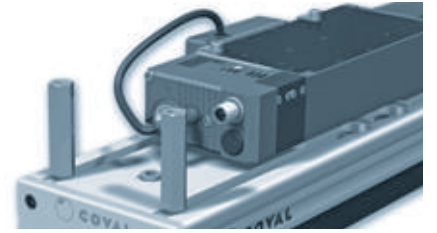
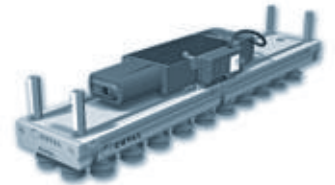

Multi-stage Vacuum Control

When necessary, the CVGL series vacuum grippers with integrated vacuum generator (versions D1 and D2) can be equipped with a vacuum and/or blow-off control valve to optimize product release. This also enables cleaning of the vacuum network, flow control nozzles, check valves, or airtight valves.

A vacuum switch or analog gauge is available as an option for those requiring a visual display of the vacuum level in the system (see below).

Vacuum Control: 2 Solutions

Model CVGL__S_: vacuum pump with **NC** vacuum control and **NC** blow-off control. In the event of power failure, vacuum is no longer generated. In the event of compressed air failure, the vacuum is no longer maintained.

- **NC** blow-off and vacuum control: solenoid valves
- Choice of blow-off settings (only on CVGL__S2_ models):
 - controlled by external signal
 - automatic timer from 50 to 9999 ms (advantage: saves one controller output)

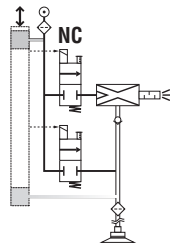

Model CVGL__V_: vacuum pump with **NO** vacuum control and **NC** blow-off control. In the event of power failure, vacuum is still generated: object is held in place → fail-safe.

In the event of compressed air failure, the vacuum is no longer maintained.

- **NO** vacuum control solenoid valve
- **NC** blow-off control solenoid valve
- Blow-off controlled by external signal

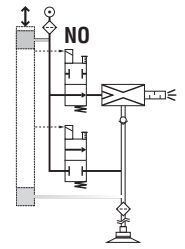

Electrical Connections

CVGL__S1_ / V1:

- One M12 5-pin male connector

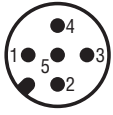

- | | |
|---|----------------------------------------|
| 1 | / |
| 2 | 24 V DC suction command ⁽¹⁾ |
| 3 | 0 V - GND |
| 4 | 24 V DC blow-off command |
| 5 | / |

⊗ : connections for ⊗ IO-Link

⁽¹⁾ 24 V DC suction command, depending on version:

- **S**: 24 V DC vacuum control
- **V**: 24 V DC vacuum off command



CVGL__S2_ / V2:

- One M12 5-pin male connector

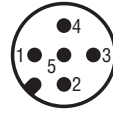

- | | |
|-----|----------------------------------------|
| ⊗ 1 | 24 V DC |
| ⊗ 2 | 24 V DC suction command ⁽¹⁾ |
| ⊗ 3 | 0 V - GND |
| ⊗ 4 | 24 V DC object gripped D01 - C/Q |
| 5 | 24 V DC blow-off command |

- One M8 4-pin male connector → HMI



- | | |
|---|---------------|
| 1 | 24 V DC |
| 2 | RS485 (DATA+) |
| 3 | 0 V - GND |
| 4 | RS485 (DATA-) |



Vacuum Level Display

When required, CVGL series grippers can incorporate a vacuum level display with an electronic vacuum switch or vacuum gauge:

■ Option VA - electronic vacuum switch

with 3-color display (PSD100CPNP):

CVGL____X__VA

- Pressure rating range: 0 ~ -101.3 kPa.
- Pressure setting range: 10 ~ -101.3 kPa.
- Max. pressure: 300 kPa.
- Fluid: Air, non-corrosive/non-flammable gas.
- Hysteresis: adjustable.
- Response time: ≤ 2.5ms, with anti-vibration function.
- 7 segment LCD display: 2 color (red/green) main display, orange sub-display (refresh rate: 5 times/1sec.)
- Choice of pressure unit display: kPa, MPa, kgf/cm², bar, psi, inHg, mmHg.
- Power supply voltage: 12 to 24 V DC ±10%.
- Current consumption: ≤ 40 mA (without load).
- Repeatability (switch output): ≤ ±0.2% F.S. ±1 digit.
- Electrical connection: M8 (4-pin).
- Protection: IP40.
- Ambient temperature range: 0 – 50° C (operation).
- Material (enclosure): PA 6.6 20%GF.

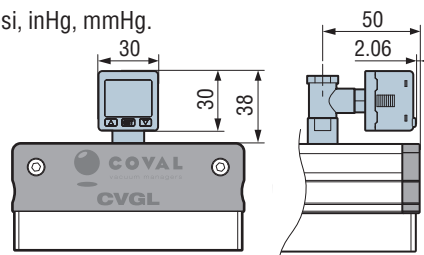

■ Option VF - vacuum gauge

(VAF11140):

CVGL____X__VF

- Vacuum gauge with needle.
- Damping: by silicone movement (patented).
- Measuring: Bourdon tube in CuSn.
- Precision: cl. 2.5 (+/- 2.5% of max. scale value).
- Frame: black ABS

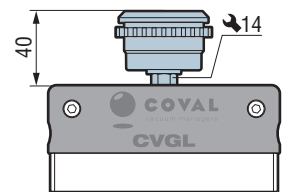





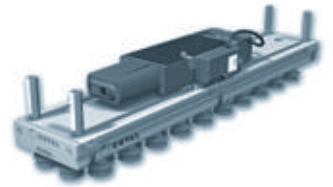

Note: all dimensions are in mm.

CVGL

Compact and Light Vacuum Grippers

Configuring a CVGL Vacuum Gripper

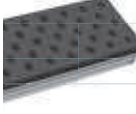

CVGL 424 D		VSA33JK	X	H	X
OVERALL LENGTH					ASSEMBLY TYPE
424 mm	424				X Screw mounting
624 mm	624				C Quick-mounting spring clips
824 mm	824				
HOLE/CUP PATTERN LAYOUT					
Staggered	 Q				
Straight*	 D				
* Only available for "maxi" type gripping interface with minimum suction cup Ø 26mm.					
SUCTION CUPS GRIPPING INTERFACES			FILTER		TECHNOLOGY
	"mini" type interface: 2.5 bellows suction cups Ø 14 mm in silicone 35 Shore with flow control nozzles.	VSP14BF	X Without		H Flow control nozzles
	"medium" type interface: 1.5 bellows suction cups Ø 25 mm in natural rubber with flow control nozzles.	VSA25JI			
	"maxi" type interface: 1.5 bellows suction cups Ø 33 mm in natural rubber with flow control nozzles.	VSA33JK			
	"maxi" type interface: 2.5 bellows suction cups Ø 30 mm in white silicone 35 Shore with flow control nozzles.	MVS30EK			
FOAM GRIPPING INTERFACES			FILTER		TECHNOLOGY
	Foam "mini" type interface, EPDM (thickness 20 mm)	F2S	X Without		H Flow control nozzles
	Foam "maxi" type interface, EPDM (thickness 20 mm)	F2B	F With filter		E Airtight valves
COVAL-flex GRIPPING INTERFACES					V Check valves
	"COVAL-flex" gripping interfaces are designed to respond to specific applications. Our vacuum team will recommend and define any applications of yours which can benefit from its special features.				

CVGL

13

SPECIAL VERSIONS

There can be instances where the standard CVGL versions will not match your application requirements. COVAL can provide you personalized solutions based on your specifications, by integrating specific function and suggesting custom lengths and suction cup types.

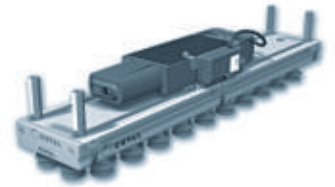

	D1	S		1		K		VA
VERSION WITHOUT VACUUM GENERATOR			GENERATOR CONTROL		GENERATOR CONFIGURATION		EXHAUST	
Without vacuum generator	G0	N	Without	0	Without	X	Without	
VERSIONS WITH VACUUM GENERATOR*			GENERATOR CONTROL		GENERATOR CONFIGURATION		EXHAUST	
1 x CMSHDE_50 multi-stage vacuum pump Flow rate: 700 NI/min	D1	N	Without	0	Without	K	Through-type silencer	
1 x CMSHDE_100 multi-stage vacuum pump Flow rate: 1100 NI/min	D2	S*	CMSHDE_S_ Vacuum pump with NC vacuum control and NC blow-off control. Choice of blow-off settings (only on CVGL__S2_models): ▪ Controlled by external signal ▪ Automatic timer from 50 to 9999 ms (advantage: saves one controller output).	1	CMSHDE_VOC15P_ Multi-stage vacuum pump without vacuum switch and HMI ▪ One M12 5-pin male PNP ▪ Digital inputs/outputs mode (SIO)			
2 x CMSHDE_100 multi-stage vacuum pump Flow rate: 2200 NI/min	D3	V*	CMSHDE_V_ Vacuum pump with NO vacuum control and NC blow-off control. ▪ Blow-off controlled by external signal	2	CMSHDE_VXC15X_ Multi-stage vacuum pump with integrated vacuum switch and pressure sensor, without HMI ▪ One M12 5-pin male configurable as PNP or NPN ▪ One M8 4-pin male for remote HMI ▪ Electronic vacuum switch ▪ Digital Output DO1 "object gripped" 24 V DC / NO ▪ Digital input/outputs mode (SIO) / IO-Link ▪ Compatible with HMI (for VI option)			
* See p.13/10 table of possible configurations								
* Only for D1 and D2.								
VACUUM LEVEL DISPLAY								
Without								VO
	Vacuum switch with electronic display							VA
	Vacuum gauge (for versions with control, option available for 624 mm in length and longer)							VF
	HMI on CMS HDE (compatible with S2 and V2 versions only)							VI

CVGL

Compact and Light Vacuum Grippers

Examples of Composed Part Numbers

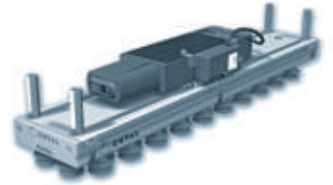

CVGL424DVSA33JKXHXD2S1KVA

CVGL vacuum gripper length 424mm, "straight" cup pattern layout, "maxi" type gripping interface, 1.5 bellows suction cups Ø33mm in natural rubber with flow control nozzles, with 1 integrated vacuum generator CMSHDE_100, vacuum generator control and NC blow-off, vacuum level display with electronic display vacuum switch.

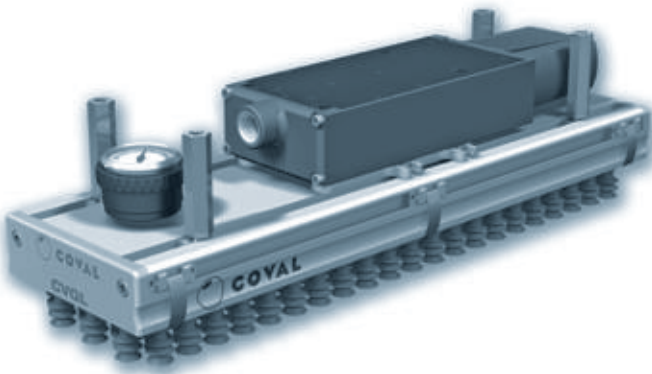
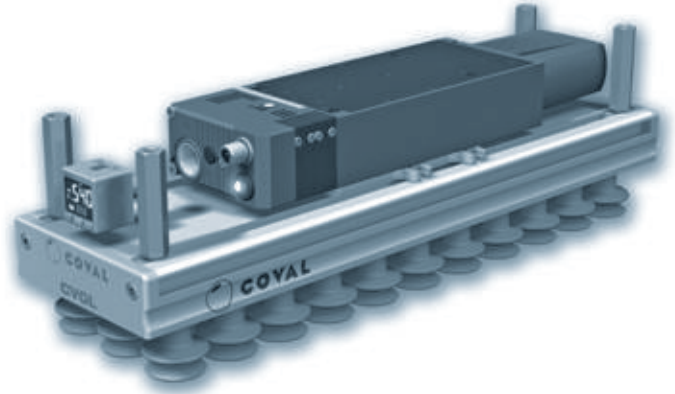

CVGL424QVSP14BFXHCD1NOKVF

CVGL vacuum gripper length 424mm, "staggered" cup pattern layout, "mini" type gripping interface, 2.5 bellows suction cups Ø33mm in silicon 35 Shore with flow control nozzles, with 1 integrated vacuum generator CMSHDE_50, without vacuum generator control and vacuum level display with mechanical gauge vacuum switch.

CVGL624QMVS30EKXHXGONOXVA

CVGL vacuum gripper length 624mm, "staggered" cup pattern layout, "maxi" type gripping interface, 2.5 bellows suction cups Ø30mm in silicon 35 Shore with flow control nozzles, without vacuum generator, and vacuum level display with electronic display vacuum switch.

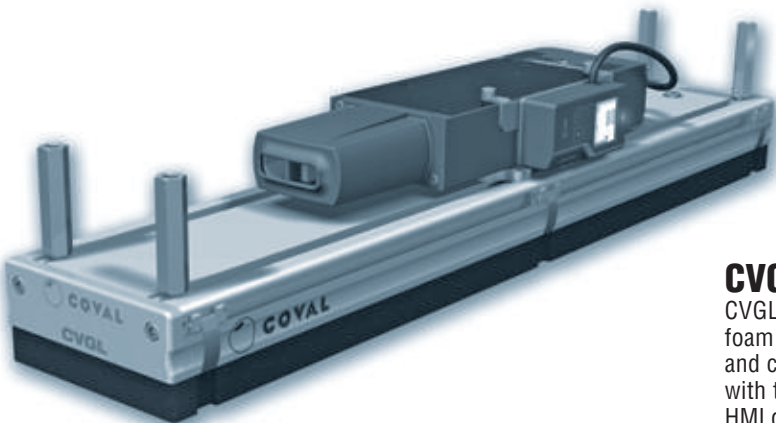
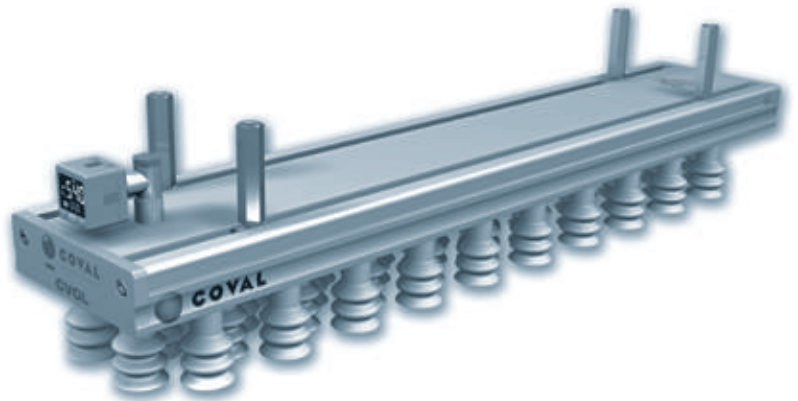

CVGL624QF2BFVD2S2KVI

CVGL vacuum gripper length 624mm, "staggered" hole pattern, foam "maxi" interface with quick mounting spring clips, with filter and check valves, with CMSHDE_100_ multi-stage vacuum pump, with through-type silencer, NC vacuum control and blow-off, with HMI display.

CVGL

Compact and Light Vacuum Grippers

Examples of Composed Part Numbers

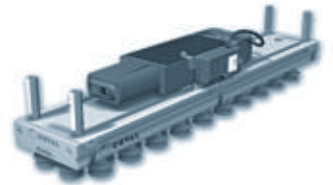

CVGL824QF2SXHCGON0XVF

CVGL vacuum gripper length 824mm, "staggered" cup pattern layout, foam "mini" type gripping interface with quick mounting spring clips, without filter, with flow control nozzles, without vacuum generator, with vacuum level display with mechanical gauge vacuum switch.

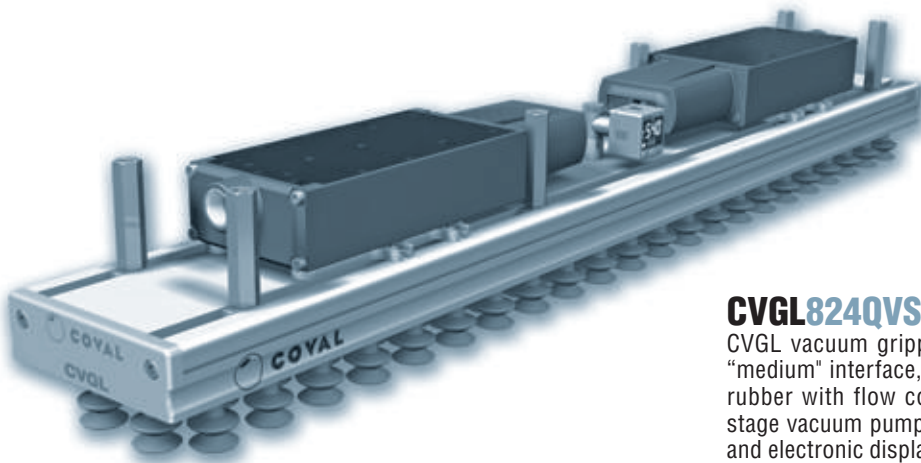
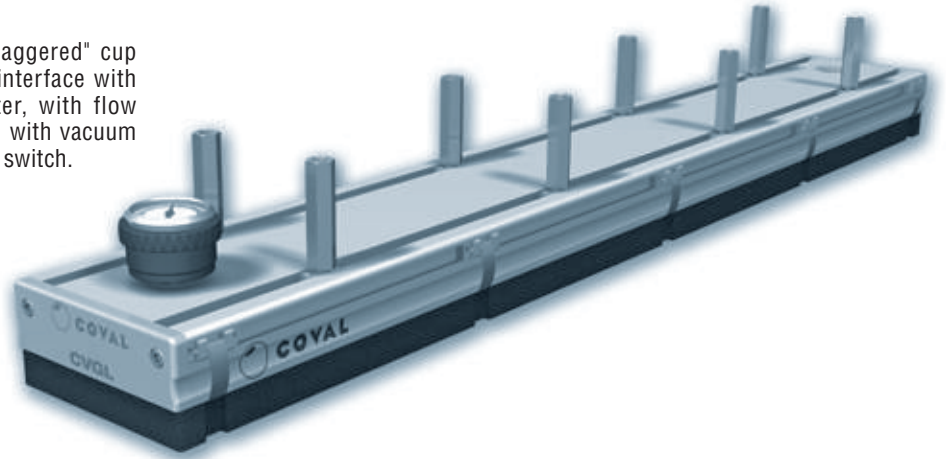

CVGL824QVSA25JIXHDX3NOKVA

CVGL vacuum gripper length 824mm, "staggered" cup pattern, "medium" interface, suction cups 1.5 bellows Ø25 mm in natural rubber with flow control nozzles, with 2 CMSHDE_100_ multi-stage vacuum pumps without control, with through-type silencer, and electronic display vacuum switch.

MVG Series modular vacuum grippers

For applications requiring customized dimensions, COVAL has developed a modular vacuum gripper, the **MVG Series**.

Thanks to their modularity, the MVG vacuum grippers offer the optimal handling solution for various sizes, shapes, and weights.

- Customized formats from 150x150mm to 1200x1000mm.
- Configurable gripping interface (foam, suction cups, or COVAL-flex).
- Multi-zone.
- Staggered grip / release points.
- Integrated or external vacuum generator.
- Adaptable to all industry sectors.



CVGL

Compact and Light Vacuum Grippers

Dimensions and Mounting Options

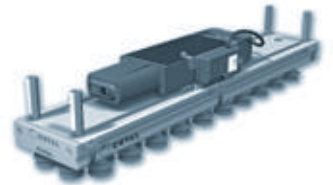

G0 versions

(with external vacuum generator).

The COVAL CVGL series vacuum grippers G0 version (with external vacuum generator), can be mounted on all types of automated or robotic systems, via M8 spacers, sliding in the grooves of the aluminum profile.

- CVGL 424 and 624: 4 x M8 spacers.
- CVGL 824: 6 x M8 spacers.

Dimensions

	CVGL424	CVGL624	CVGL824
A	424	624	824
B	408	608	808

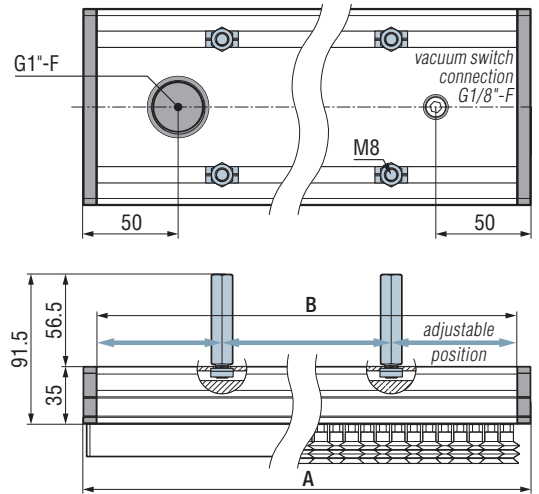
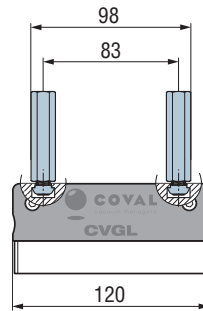

D1 or D2 versions, without control

(1 integrated vacuum generator, CMS HDE series).

The COVAL CVGL series vacuum grippers, D1 and D2 versions, are mounted on all types of automated systems via M8 spacers pre-installed on sliding nuts.

- CVGL 424 and 624: 4 x M8 spacers.
- CVGL 824: 8 x M8 spacers.

Dimensions

	CVGL424	CVGL624	CVGL824
A	424	624	824
B	408	608	808
C	15	134	233
D	125	207	307
E	76	194	294
F	116	198	298

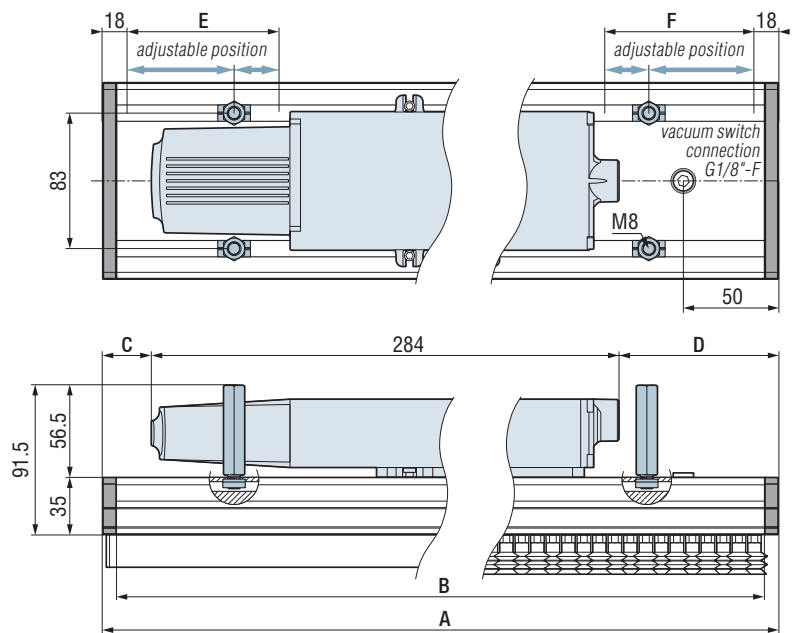
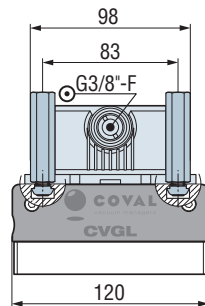

You can access 3D files of all our products in formats compatible with the main CAD software on our website
www.coval.com

Note: all dimensions are in mm.

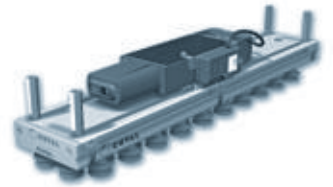

D1 or D2 versions, with control

(1 integrated vacuum generator, CMS HDE series).

The COVAL CVGL series vacuum grippers, D1 and D2 versions, are mounted on all types of automated systems via M8 spacers pre-installed on sliding nuts.

- CVGL 424 and 624: 4 x M8 spacers.
- CVGL 824: 8 x M8 spacers.

Dimensions

	CVGL424	CVGL624	CVGL824
A	424	624	824
B	408	608	808
C	15	134	234
D	78	160	260
E	76	194	294
F	47	129	229

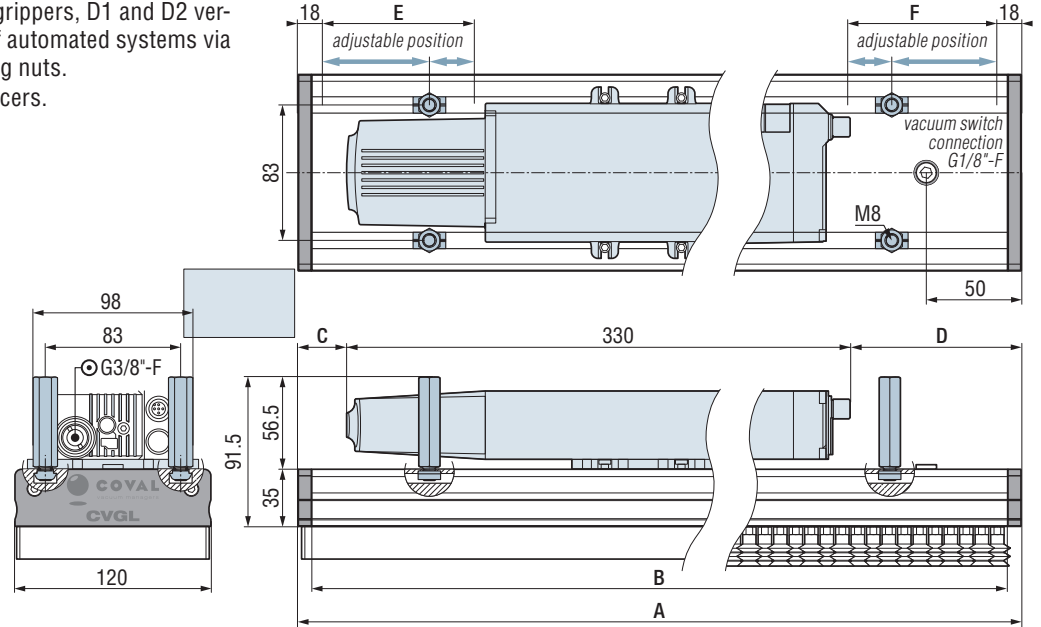

D3 versions

(2 integrated vacuum generators, CMS HDE series).

The CVGL vacuum grippers, D3 version, utilizes adjustable M8 spacers.

- CVGL 824: 6 x M8 spacers.

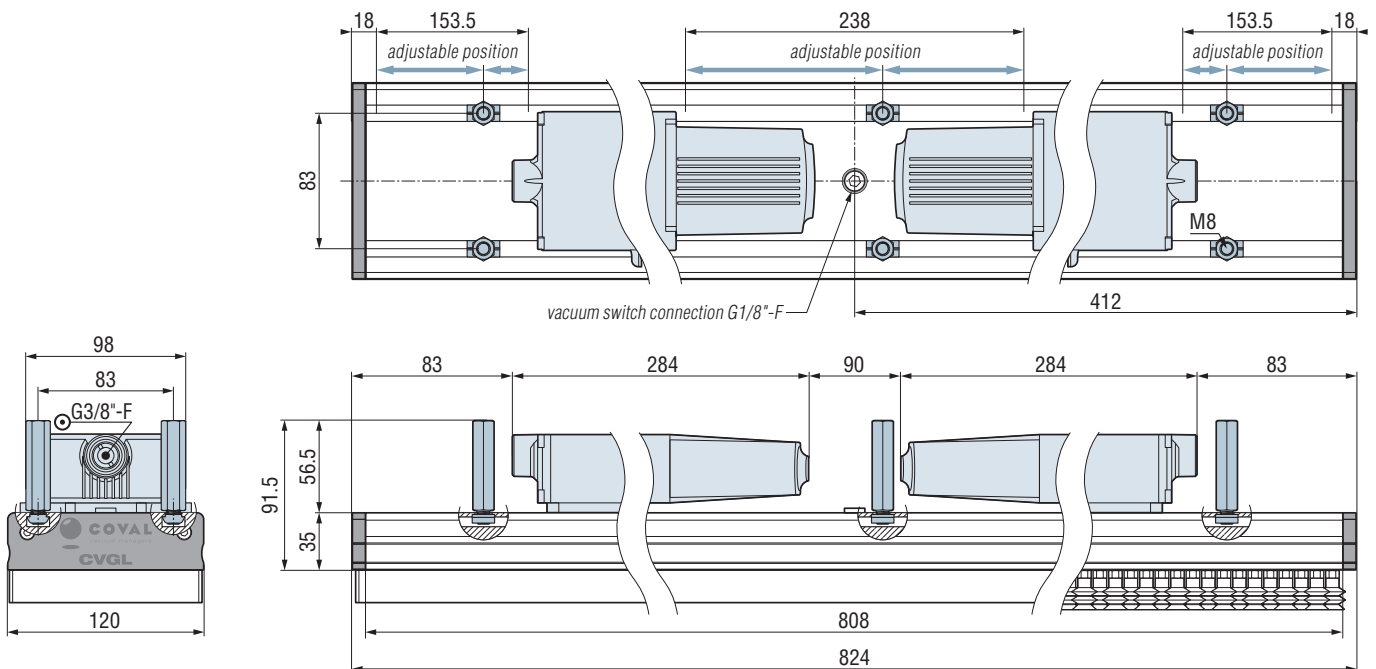

Note: all dimensions are in mm.

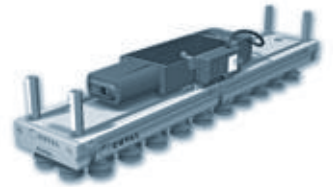

CVGL Series with Suction Cup Gripping Interface

"MINI" type suction cup gripping interface

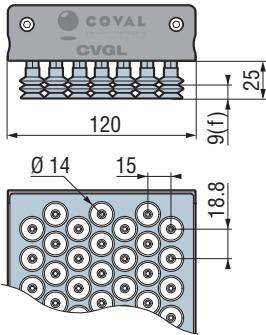

"MEDIUM" type suction cup gripping interface

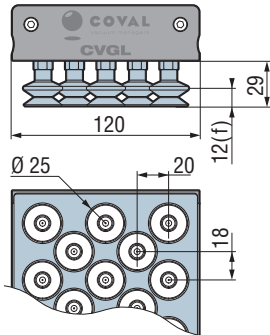

f: suction cup deflection

"MAXI" type suction cup gripping interface, STRAIGHT PATTERN

model VSA33

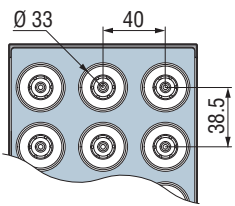
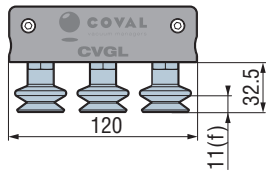

model MVS30

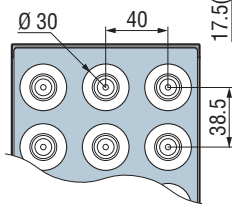
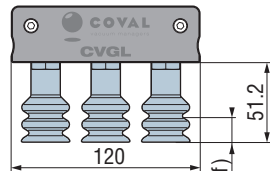

"MAXI" type suction cup gripping interface, STAGGERED PATTERN

model VSA33

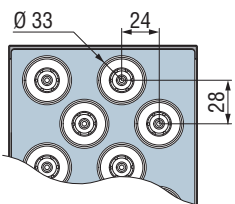
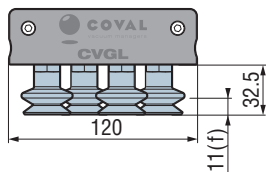

model MVS30

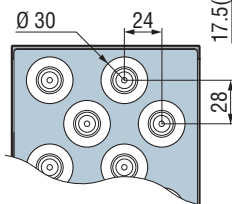
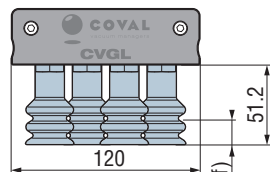

NUMBER OF SUCTION CUPS PER GRIPPING INTERFACE

	CVGL424	CVGL624	CVGL824
"Mini" type suction cup Ø14 mm (Ø16 mm max.)	150	220	297
"Medium" type suction cup Ø25 mm (Ø18 to 25 mm)	55	83	113
"Maxi" type, STRAIGHT pattern Ø30 or Ø33 mm suction cups (Ø36 mm max.)	33	48	63
"Maxi" type, STAGGERED pattern Ø30 or Ø33 mm suction cups (Ø36 mm max.)	28	42	58

CVGL Series with Foam Gripping Interface

"MINI" type foam gripping interface

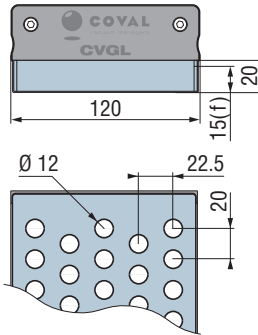

"MAXI" type foam gripping interface

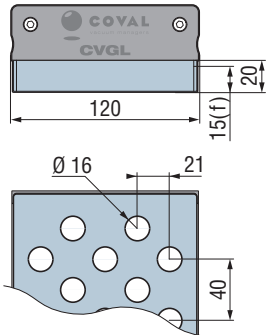

f: foam compression

NUMBER OF GRIPPING POINTS PER INTERFACE

	CVGL424	CVGL624	CVGL824
"mini" type gripping interface Ø12 mm	98	148	198
"maxi" type gripping interface Ø16 mm	50	75	100

CVGL Series with "COVAL-flex" Gripping Interface

COVAL-flex

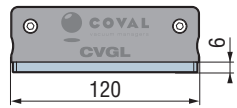

Option: quick installation of the interface

Option: CVGL ___ **C** quick installation of the interface via spring clips

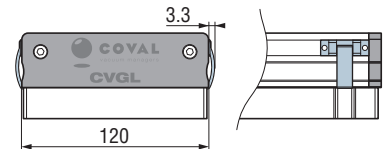

Option: HMI mounted on the vacuum generator

Option: CVGL ___ **VI**

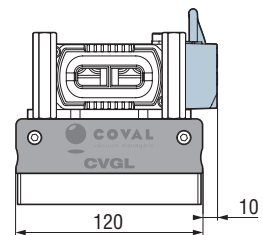

Note: all dimensions are in mm.

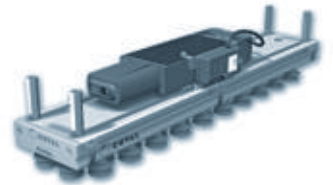

General Characteristics

- Temperature: from 0 to 50°C (32 to 122° F).
- Material of the gripper: aluminum, PA 6.6 15% GF, brass, stainless steel, neoprene.
- Foam gripping interface material: EPDM.
- Suction cup gripping interface materials:
 - "mini" type interface: silicone 35 Shore.
 - "medium" type interfaces: natural rubber 50 Shore.
 - "maxi" type interfaces: natural rubber 50 Shore or white silicone 35 Shore.

Multi-stage Vacuum Pumps General Characteristics

- Supply: non-lubricated air, filtered to 5 microns, according to standard ISO 8573-1:2010 [3:4:4]
- Operating pressure: from 2 to 8 bar
- Optimal dynamic pressure:
 - CMSHDE_NVO (for CVGL_GON_ grippers) without control: 5.5 bar.
 - CMSHDE_S_ / CMSHDE_V_ with control (for CVGL_S_ / CVGL_V_ grippers): 6 bar.
- Pressure connection: G3/8"-F with removable 350 µm filter screen
- Max. vacuum: 80%
- Air suction flow rate: 700 to 2200 NI/min
- Air consumption: 220 to 840 NI/min
- Noise level:
 - CMSHDE90X50_K : 59 dBA
 - CMSHDE90X100_K : 62 dBA
- Degree of protection: IP65
- Max. operating frequency: 4 Hz
- Endurance: 50 million cycles
- Materials: PA GF, brass, aluminum, steel, NBR, PU, FKM
- M12 and M8 male connectors (depending on version)

Integrated electronics

- 24 V DC power supply (regulated ±10%)
- Inputs/outputs protected against reversed wiring and polarity
- Consumption: 170 mA max. (without load)

Only on models CMSHDE_VX_ installed on CVGL_S2 / V2:

- Vacuum measuring range: 0 to 99%
- Pressure measuring range: 0 to 10 bar
- Vacuum and pressure measurement accuracy: ±1.5% of the range, compensated for temperature
- Input/Output switching mode: PNP or PNP/NPN configurable
- Digital inputs/outputs mode (SIO) / IO-Link

DO1 output signal

Only on models CMSHDE_VX_ installed on CVGL_S2 / V2:

- Configurable as PNP or NPN
- NO or NC
- Breaking capacity: 330 mA
- DO1: object gripped output (factory setting 40%)

Diagnostics

Only on models CMSHDE_VX_ installed on CVGL_S2 / V2:

- Instantaneous vacuum level (unit transmitted over IO-Link: mbar)
- Available information: Object gripped, object lost
- Cycle counters (vacuum, blow-off, object gripped, object lost, etc.)
- Supply pressure monitoring

- Supply voltage monitoring
- Product part number and serial number
- Software version

Indicator

Only on models CMSHDE_VOC15P_ installed on CVGL_S1 / V1:

- Status LED for control functions:
 - Green LED: vacuum control
 - Orange LED: blow-off control

Information displayed on HMI (VI option)

- LED gripping status indicator on front panel (Green: object gripped, Red: object lost)
- 1.54" high-visibility color LCD display:
 - Displays vacuum level with bar graph and thresholds
 - Warns when service life has been exceeded (> 50 million cycles)
 - Explicit fault messages
 - "Suction cup" icon indicating the status of control functions:
 - Green suction cup: vacuum control
 - Orange suction cup: blow-off control
 - Red suction cup: simultaneous vacuum and blow-off control
 - Configurable display orientation: 0 - 90 - 180 - 270°

Parameter settings available with the HMI or IO-Link

Only on models CMSHDE_VX_ installed on CVGL_S2 / V2:

- Choice of blow-off type (CVGL_S2 only):
 - Controlled
 - Automatic timed, adjustable from 50 to 9999 ms
- Object gripped (L1) control thresholds
- Whenever required by the application, specific threshold and hysteresis settings that are different from the initial factory settings can be defined: L1 = 40%, h1 = 10%

+ Additional settings available with the HMI

(performed with 4-key membrane keyboard):

- Choice of language: EN, FR, DE, IT, or ES
- Choice of vacuum measurement unit (kPa, %, mbar, inHg)
- Choice of pressure measurement unit (MPa, bar, psi)
- Monostable electrical manual controls

Communication

IO-Link

- Revision: 1.1
- Transmission rate: COM3 - 230.4 kbit/s
- Min. cycle time: 1 ms
- SIO mode: Yes
- Process Data Input (PDI): 6 bytes
- Process Data Output (PDO): 1 byte
- IO device description file (IODD) available for download

NFC

- COVAL VACUUM MANAGER Mobile app available:
 - Android, version 8.1 and higher
 - iOS, version 13 and higher

MVG

Modular Vacuum Grippers

General Information

COVAL's MVG series vacuum grippers fully meet integrator and end user expectations in terms of power, robustness, communication, and ease of setup and use, while they remain compact and lightweight for easier integration in a smart factory.

Their highly modular and flexible design makes them an optimal solution for handling objects of various sizes, shapes, and weights.

COVAL's next generation vacuum grippers feature CMS HDE series multi-stage vacuum pumps. These pumps have a heavy-duty design offering high reliability even in harsh environments (IP65) and a long service life, withstanding up to 50 million cycles. The modular design of these vacuum pumps contributes to their durability and allows for special configurations as well as targeted maintenance of specific parts to optimize reparability.

Next generation CMS HDE multi-stage vacuum pumps thus further increase the reliability of MVG series vacuum grippers and their adaptability.



Industry-specific applications

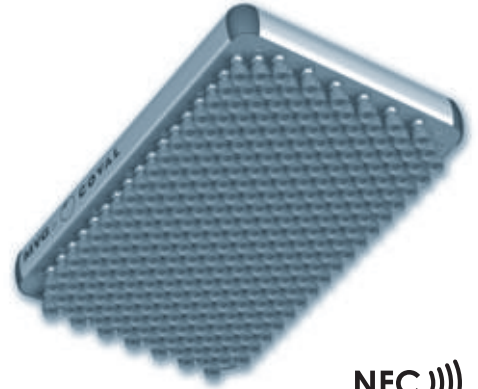
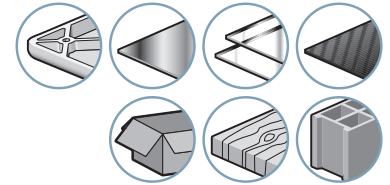

NFC))))

IO-Link

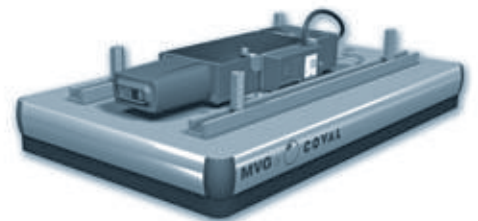

Custom Made by Design

The modular design of the MVG series vacuum grippers with standard sub-assemblies provides great flexibility when it comes to selecting dimensions, gripping interface, and the vacuum generator to fully meet the application requirements.

Moreover, to optimize production cycles and palletization planning, MVG grippers can be equipped with several independent gripping zones (multi-zone), ensuring multiple or staggered gripping/release points.

Advantages

- Customized formats
- Compact and lightweight
- Multi-zone
- IO-Link and NFC communication interface
- Adapts to products
- Adapts to installation
- Easy to install and use
- Readily available
- COVAL service

Applications

MVG series vacuum grippers offer a unique solution for handling products in different industrial sectors:

- Packaging
- Plastics
- Metal
- Glass
- Concrete/stone
- Composites
- Wood



COVAL-flex

MVG

13

MVG

Modular Vacuum Grippers

General Information



Custom sizes
From 150 x 150 to
1200 x 1000 mm



Ultra-lightweight
Reduced payload weight



Configurable gripping interface
depending on the products to
be handled



Communication and control

- Digital inputs/outputs (SIO)/IO-Link
- HMI
- NFC

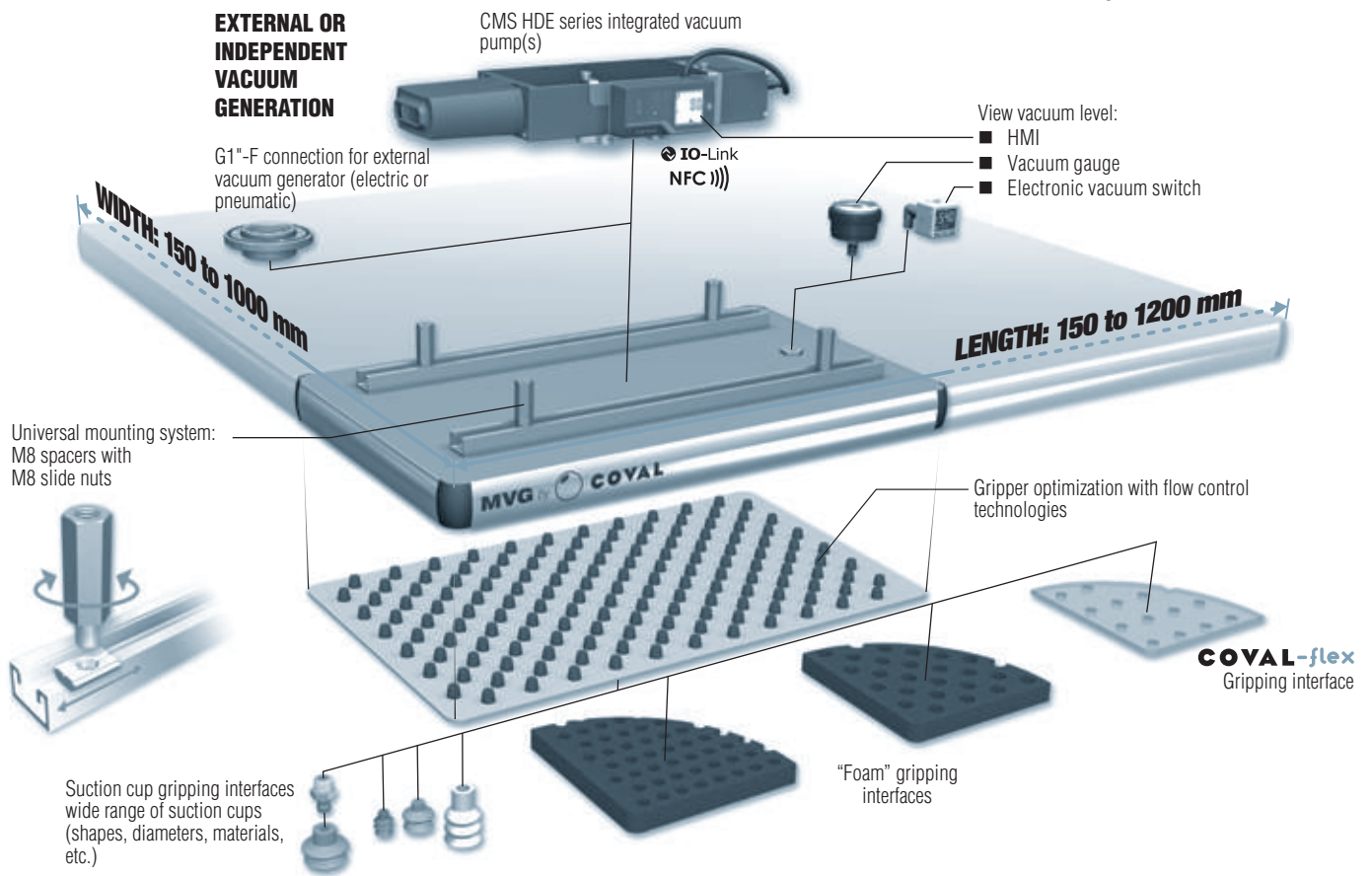

ADD COMMUNICATION AND SMART TECHNOLOGY

Integrating the CMS HDE multi-stage **VX** version vacuum pumps on **MVG** vacuum grippers makes them easier to use and set up.



Clear and efficient HMI.



Onboard installation and diagnostic tools.



Digital inputs/outputs (SIO)/IO-Link (quick and cost-effective installation, ongoing diagnostics, centralized setup, and efficient communication).



Straightforward setup and diagnostics.

A **MVG** vacuum gripper equipped with a CMS HDE vacuum pump becomes more versatile and fully compatible with the handling robots at the heart of Industry 4.0.

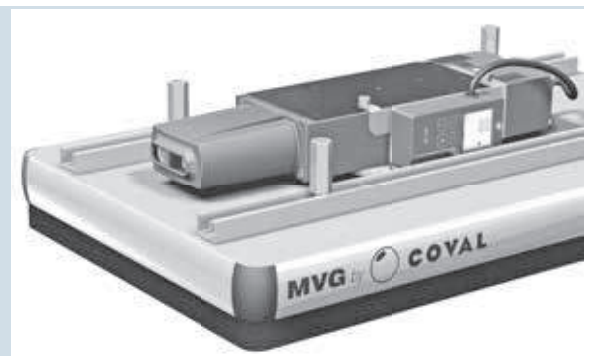

MVG

Modular Vacuum Grippers

Ultra-Lightweight and Multi-Zone Design



Ultra-Lightweight and Compact Design

The main objective in designing the MVG vacuum gripper was to reduce its footprint and weight as much as possible, while keeping a highly modular configuration to meet the needs of robotic applications.

With their patented assembly concept, MVG vacuum grippers fully meet this objective. The lightweight and strong aluminum profile frame allows for easy integration on robots. Furthermore, the vacuum connections on MVG vacuum grippers is located at the top, which makes the grippers even more compact.

The technologies and materials used in the MVG vacuum gripper's design considerably reduce the payload weight, which makes it the benchmark in its area, allowing for smaller robots to be implemented, increasing accelerations, and thus optimizing the installation for cost savings.

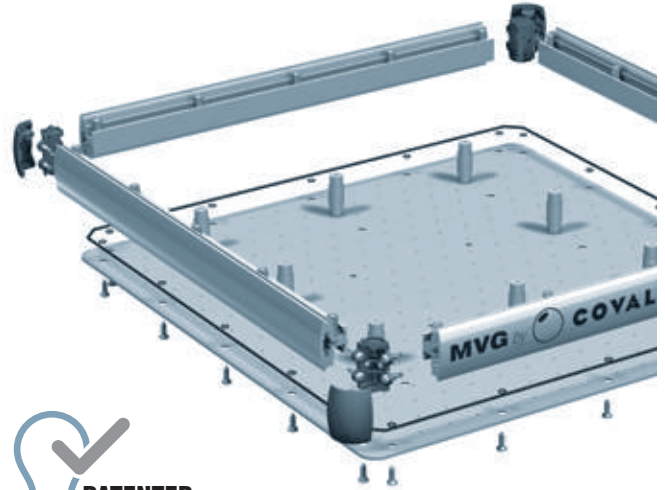

Multi-Zone

Independent gripping zones can be created on MVG vacuum grippers to ensure optimized vacuum management (higher vacuum levels, fewer leaks, and lower energy consumption). To achieve this, each zone has its own integrated or external vacuum generator.

- Staggered grip/release points
- Management of formats to be handled
- Optimized palletizing layers
- Single or multiple grip/release points

As each multi-zone application is different, COVAL will gladly assist in determining the best configuration for your process.

Examples of configuration:

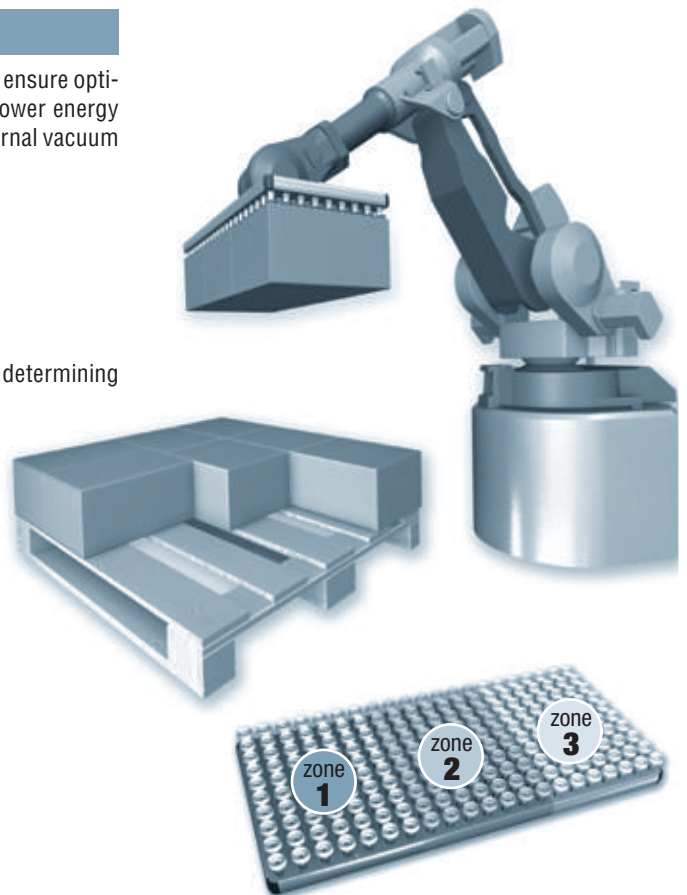
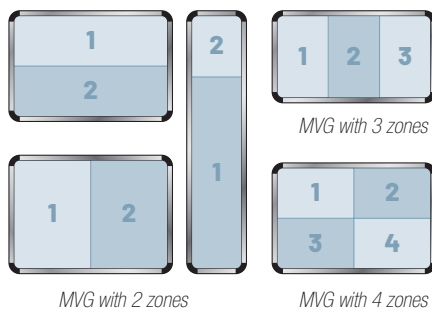

MVG

Modular Vacuum Grippers

Integrated Technologies



COVAL's MVG series lets you choose among three gripping interface technologies that can be combined to meet your vacuum handling needs: foam, suction cups, or COVAL-flex.

To optimize the performance of MVG series vacuum grippers according to the application at hand, available grip patterns have various spacing and hole diameters: → a broad range that meets all your application requirements.



Choice of Gripping Interface

"FOAM" Interface

- Handle rigid products
- Grip textured or uneven surfaces
- Flow control nozzle, airtight valve, or check valve
- 2 hole diameters (Ø 12 and 16 mm)
- 2 grip patterns



"SUCTION CUP" Interface

- Handle flexible products
- Wide range of options
- Flow control nozzle (various diameters)
- 4 types of standard suction cups (Ø 14, Ø 25, Ø 30 and Ø 33 mm)
- 3 grip patterns

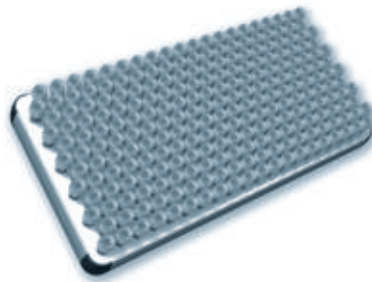

"COVAL-flex" Interface

- Handle aluminum cans, canned food, glass containers, etc.
- Flexible, extremely tear-resistant interface
- Grip pattern fully customizable according to the application



COVAL-flex

Grip Patterns

"MINI"

- Reduced hole spacing, to grip smaller objects
- Tight grip pattern ensures a strong hold, even with randomly placed objects

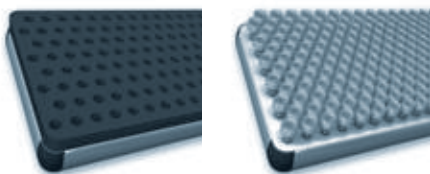

"MEDIUM"

- A medium-tight grip pattern between mini and max
- Ideal for handling dense loads with a reduced gripping surface



"MAX"

- Large gripping surface to grip heavy loads
- Ideal for handling objects with a rigid gripping surface

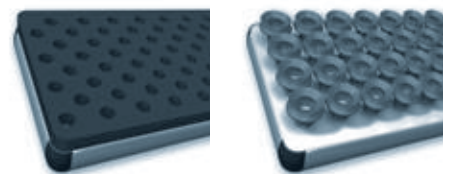

MVG

Modular Vacuum Grippers

Integrated Technologies



Flow Control Technologies

COVAL offers three different flow control technologies to optimize your vacuum gripper and fully address your application requirements.

The COVAL vacuum management team will gladly help you choose and configure your MVG vacuum gripper.

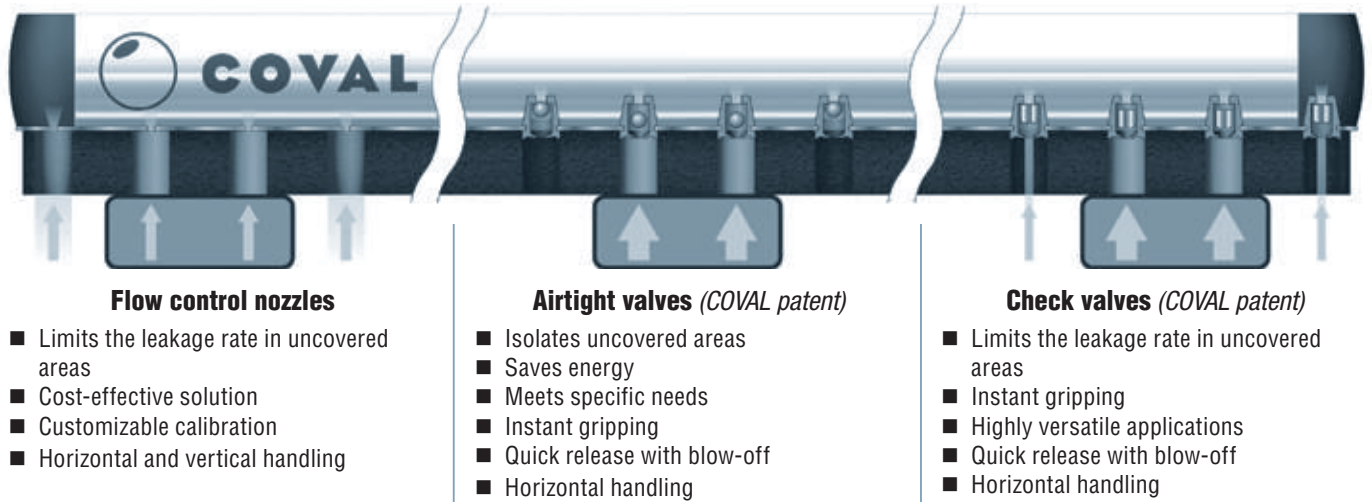

Vacuum Generation

Integrated vacuum generator, CMS HDE series

Integrating a multi-stage vacuum generator on the MVG gripper provides a comprehensive and compact gripping solution, and ensures easy integration in your process.

Options: add a vacuum and/or blow-off control valve with M12 connector and a vacuum level display (electronic vacuum switch display or vacuum gauge), or an HMI with LCD display.

Advantages:

- A comprehensive solution
- 3 levels of suction power
- Option: vacuum and blow-off control
- Option: vacuum level display
- Option: IO-Link communication interface

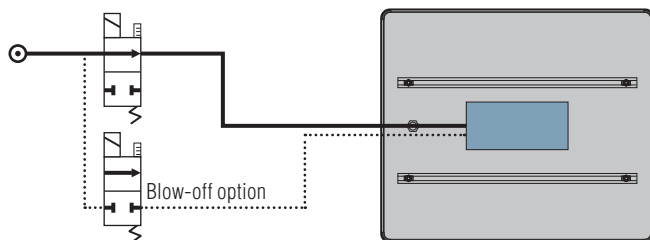

External vacuum generator

MVG vacuum grippers can also be used with an external vacuum generator. Depending on the application, an independent generator may be required (impeller, electric vacuum pump, or CMS HD series multi-stage vacuum pump). Version G0 of the MVG series vacuum grippers features a G1"-F flange to easily connect the vacuum source.

Option: add a vacuum level display (electronic vacuum switch display or vacuum gauge).

Advantages:

- Reduced weight
- Adapts to environment in which it is used
- Option: vacuum level display

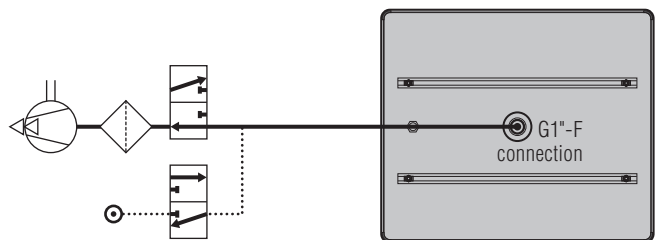

Technical data of integrated CMS HDE series multi-stage vacuum pumps

Vacuum gripper	Integrated vacuum pump	Consumption (NI/min)	Flow rate (NI/min)	Max. vacuum (%)	Noise level (dBA)
MVG ___ D1	CMSHDE_50	220	700	80	59
MVG ___ D2	CMSHDE_100	420	1100	80	62
MVG ___ D3	2xCMSHDE_100	840	2200	80	65

Vacuum pump configurations by gripper length

Integrated vacuum pump	Version	Min. gripper dimensions*
CMSHDE_50	Without control (version NVO)	450 x 260 mm
	With control (versions VOC15P and VXC15P)	500 x 260 mm
CMSHDE_100 (Version D2)	Without control (version NVO)	450 x 260 mm
	With control (versions VOC15P and VXC15P)	500 x 260 mm
2xCMSHDE_100 (Version D2)	Without control (version NVO)	900 x 260 mm

* Dimensions are indicative and may change depending on selected options.

MVG

Modular Vacuum Grippers

Integrated Multi-Stage Vacuum Pumps



To adequately address the requirements of each application, there is a wide range of **CMS HDE series** multi-stage vacuum pump configurations to choose from for MVG series vacuum grippers.

MVG__D_NOK

CMSHDE__NVOG4K multi-stage vacuum pump

- Without control

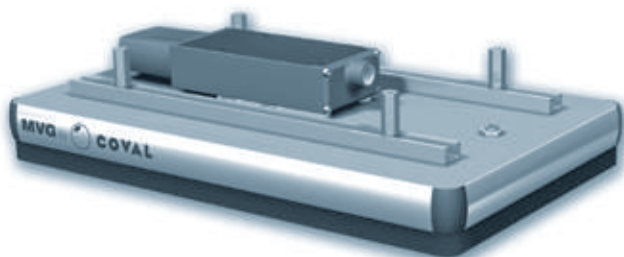

MVG__D_S1 / V1K

CMSHDE__VOC15PG4K multi-stage vacuum pump

- With vacuum and blow-off control
- Without vacuum switch
- One M12-5-pin connector
- Visual vacuum/blow-off indicators
- Digital inputs/outputs mode

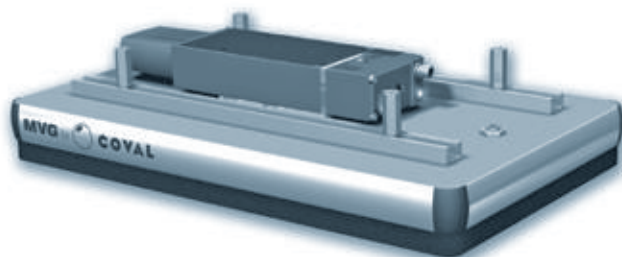

MVG__D_S2 / V2K

CMSHDE__VXC15PG4KD multi-stage vacuum pump

- With vacuum and blow-off control
- With vacuum switch and pressure sensor
- One M12-5-pin connector
- One M8 4-pin connector for the HMI (option VI)
- Digital inputs/outputs mode (SIO)/IO-Link



Version **VI**: Clear and efficient HMI: includes all required inputs for full operation of CMS HDE multi-stage vacuum pumps.

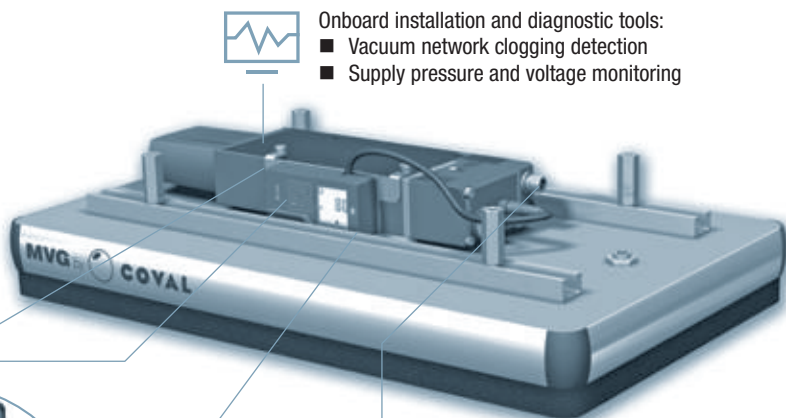

Onboard installation and diagnostic tools:

- Vacuum network clogging detection
- Supply pressure and voltage monitoring



Inputs/Outputs
Digital inputs/outputs (SIO)/IO-Link

- M12 5-pin connector

Status indicator (2 colors)

1.54" high-visibility color LCD display with clear multilingual messages and straightforward settings menu

Settings keypad



NFC)))



Straightforward setup and diagnostics made possible by NFC technology and COVAL Vacuum Manager mobile app.

Modularity/Maintenance

The CMS HDE multi-stage vacuum pumps have been designed to withstand the demands from all your applications and to guarantee a high level of performance. However, handling certain parts may require replacement or cleaning.

The modular design of the CMS HDE multi-stage pumps ensures easy maintenance as the functions are all easily accessible.

350 µm pressure filter screen G3/8"

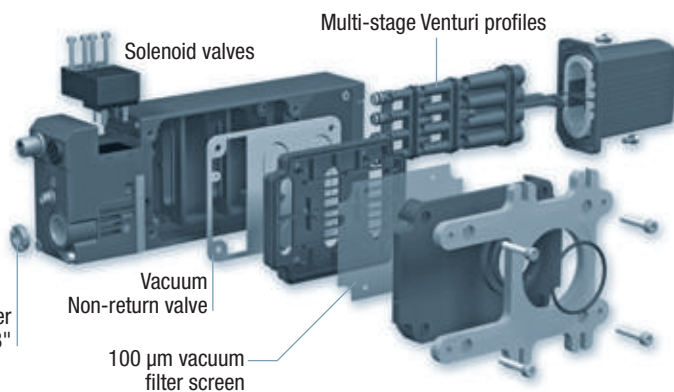

MVG

Modular Vacuum Grippers

Straightforward Communication



Easier Integration, Use, and Diagnostics

Designed to keep vacuum gripper use and management as straightforward as possible and thus allowing for their easy integration in your smart factory, MVG__S2 / V2_ vacuum grippers include

various features that allow for their setup, use, and diagnostics in all situations and at all levels (operators, process, networked factory).

Settings, Diagnostics, and Process Data



CONFIGURABLE SETTINGS

- Choice of language: EN, FR, DE, IT, or ES
- "Object gripped" control thresholds
- Automatic blow-off
- Unit of measurement for vacuum: kPa, %, mbar, inHg
- Unit of measurement for pressure: MPa, bar, psi
- Software updates



DIAGNOSTIC

- Cycle counters (vacuum and blow-off control, objects gripped, objects lost, etc.)
- Clogging detection function
- Supply pressure and voltage monitoring
- Software version
- Product part number and serial number



PROCESS INPUT DATA

- Vacuum and blow-off control



PROCESS OUTPUT DATA

- Instantaneous vacuum level
- Object gripped and object lost information
- Alarms (high/low pressure, high/low voltage)
- Instantaneous pressure level



IO-Link

The IO-Link system that is integrated in **CMSHDE_VXC15X** multi-stage vacuum pumps ensures efficient real-time communication between MVG vacuum grippers and any higher-level protocol (EtherNet/IP, PROFINET, EtherCAT, etc.) required to monitor the production line. It can be used to control pumps, configure settings, and get feedback to ensure maximum productivity.

Advantages:

- Straightforward wiring, installation, and setup
- Remote setup, control, and diagnostics
- Easier preventive maintenance and vacuum pump replacement without manual setup
- Installation and diagnostic tools, and more

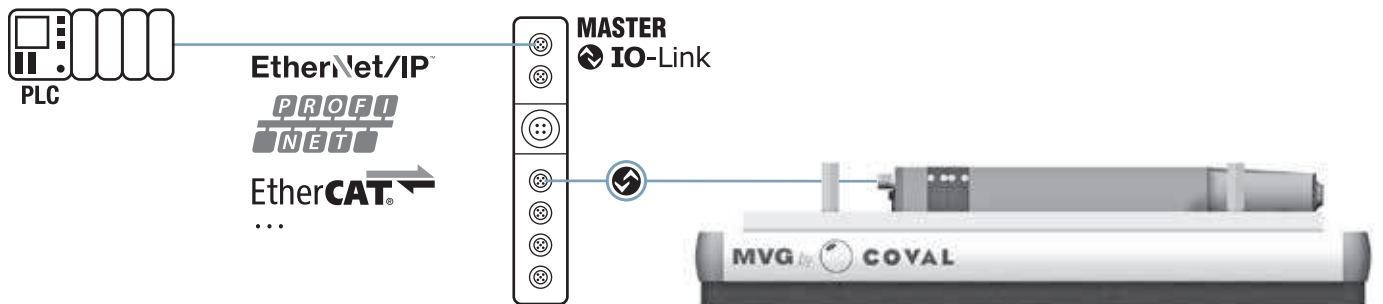

MVG

Modular Vacuum Grippers

Straightforward Communication



Mounted or Remote HMI

To make it easier to set up and use the vacuum grippers, the MVG range includes an HMI that can be mounted on the vacuum gripper or installed remotely.

Advantages:

- Place the HMI on the vacuum gripper or in an easy-to-access and visible area
- Use a single HMI for several vacuum grippers
- Copy settings from one gripper to another
- Keep using the vacuum gripper even with the HMI removed

MVG vacuum grippers compatible with the HMI:

→ MVG **S2 / V2** versions with M8 connector

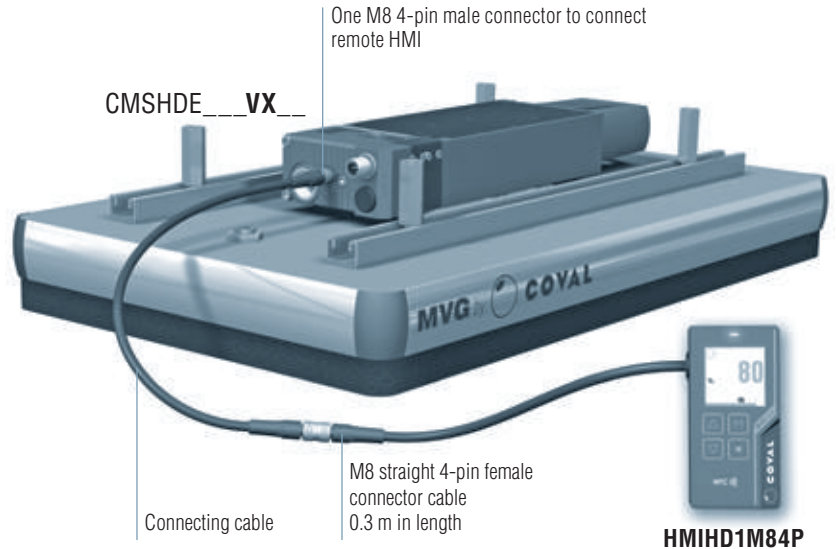

MVG **VI** version:

- HMI (part no.: **HMIHD1M84P**) + mounting plate (**HMIHD1FIXC**) mounted on the vacuum gripper

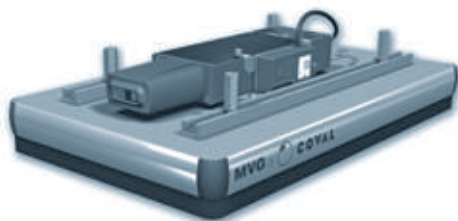

Accessory: Remote HMI (part no.: **HMIHD1M84P**)
See accessories for HMI.

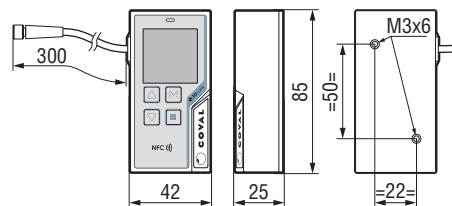

Note: all dimensions are in mm.

HMI Dialog Front Panel

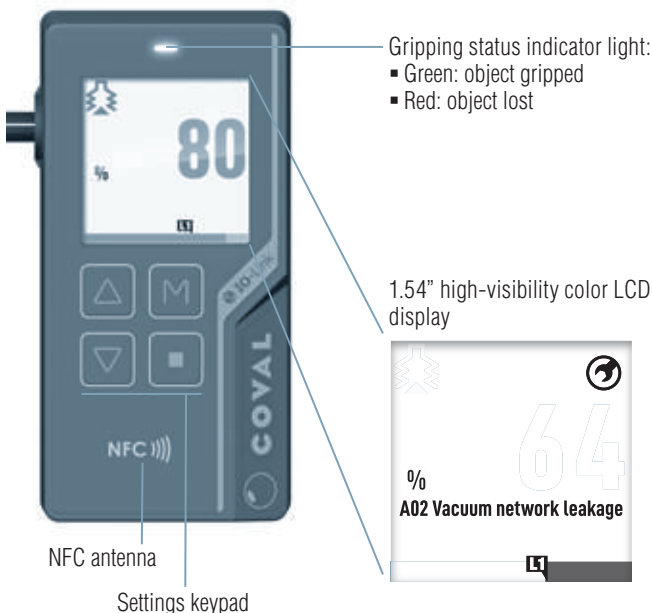

The HMI allows for easy and efficient reading of the vacuum gripper's operation. The high-visibility display includes all required inputs for full operation:

- Main information is easy to read
- Multilingual: EN – FR – DE – IT – ES
- Simple and clear event messages
- Intuitive settings and diagnostics menus
- Configurable display orientation: 0 – 90 – 180 – 270°
- Lockable to prevent undesired changes

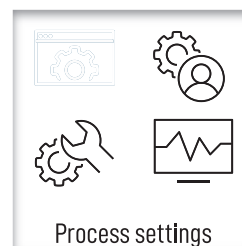

Multilingual

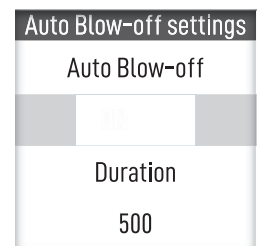

EN FR DE IT ES

Modular Vacuum Grippers

Straightforward Communication



NFC)))

The NFC wireless technology integrated in the HMI together with the COVAL Vacuum Manager app allow you to access and make changes to all the configuration and diagnostic functions using your mobile devices.

Additional functions:

- Read/write settings with the device powered off or on
- Copy settings from one gripper to another
- Save up to 5 setting configurations
- COVAL support: Send a report specifying the settings and diagnostic data to the COVAL departments to get technical support.



NFC APP: COVAL Vacuum Manager
Available for Android and iOS

Accessories for Remote HMI

Front mounting plate

- + 2 x TORX M3x6
- + 2 x CHC M5x50
- Part no.: **HMIHD1FIXA**

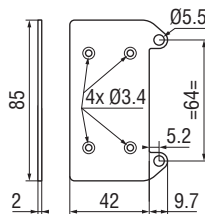

Side mounting plate

- + 2 x TORX M3x6
- + 2 x CHC M5x50
- Part no.: **HMIHD1FIXC**

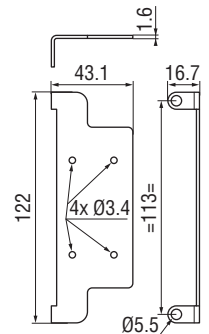
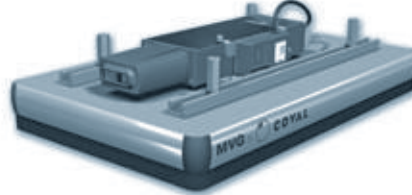

90° angled mounting plate

- + 2 x TORX M3x6
- Part no.: **HMIHD1FIXB**

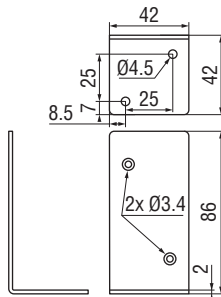

Connecting cable

M8 4-pin female/M8 4-pin male, compatible with cable chain

- 2 m length: part no. **CDM8MF4PL2**
- 5 m length: part no. **CDM8MF4PL5**
- Other lengths available upon request.



Note: all dimensions are in mm.

MVG

Modular Vacuum Grippers

Product Selection Guide

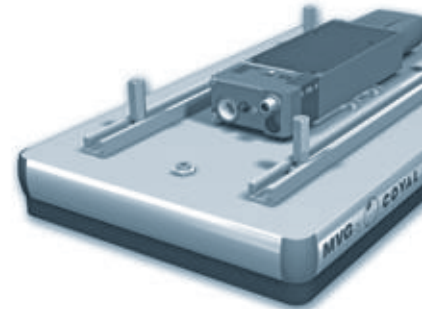
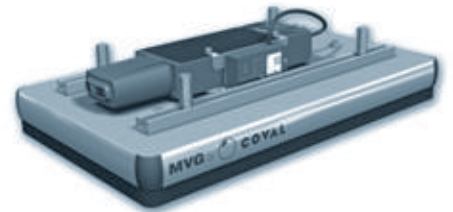

Multi-Stage Vacuum Pump Control

Where required, MVG series vacuum grippers with integrated multi-stage vacuum pump (versions D1 and D2) can be equipped with a vacuum and/or blow-off control valve to optimize object release. This also enables cleaning of the vacuum network, flow control nozzles, check valves, or airtight valves.

A vacuum switch or analog gauge is available as an option for those requiring a visual display of the vacuum level in the system (see below).

Vacuum Control: Two Solutions

Model MVG_**S**: vacuum gripper featuring a vacuum pump with **NC** vacuum control and **NC** blow-off control.

In the event of power failure, vacuum is no longer generated. In the event of compressed air failure, the vacuum is no longer maintained.

- NC blow-off and vacuum control valves
- Choice of blow-off settings (only on MVG_**S2** models):
 - Controlled by external signal
 - Automatic timer from 50 to 9999 ms (advantage: saves one controller output)

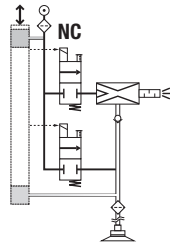

Model MVG_**V**: vacuum gripper featuring a vacuum pump with **NO** vacuum control and **NC** blow-off control.

In the event of power failure, vacuum is still generated: object is held in place → fail-safe.

In the event of compressed air failure, the vacuum is no longer maintained.

- NO vacuum control valve
- NC blow-off control valve
- Blow-off controlled by external signal

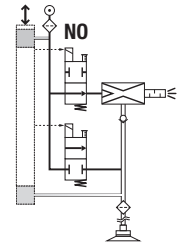

Electrical Connections

MVG_**S1/V1**:

- One M12 5-pin male connector



- | | |
|---|----------------------------------------|
| 1 | / |
| 2 | 24 V DC suction command ⁽¹⁾ |
| 3 | 0 V - GND |
| 4 | 24 V DC blow-off command |
| 5 | / |



MVG_**S2/V2**:

- One M12 5-pin male connector

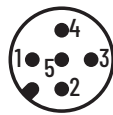

- | | |
|---|----------------------------------------|
| 1 | 24 V CC |
| 2 | 24 V DC suction command ⁽¹⁾ |
| 3 | 0 V - GND |
| 4 | 24 V DC object gripped DO1 - C/Q |
| 5 | 24 V DC blow-off command |

- One M8 4-pin male connector → HMI



- | | |
|---|---------------|
| 1 | 24 V CC |
| 2 | RS485 (DATA+) |
| 3 | 0 V - GND |
| 4 | RS485 (DATA+) |



⁽¹⁾ 24 V DC suction command, depending on version:

- **S**: 24 V DC vacuum control
- **V**: 24 V DC vacuum off command

⊗ : connections for ⊗ IO-Link



Vacuum Level Display

Where required, MVG series grippers can include a vacuum level display with an electronic vacuum switch or vacuum gauge:

■ Option VA – electronic vacuum switch with digital display (PSD100CPNP): MVG _____ X ___ VA

- Pressure rating range: 0 ~ -101.3 kPa
- Pressure setting range: 10 ~ -101.3 kPa
- Max. pressure: 300 kPa
- Fluid: air, non-corrosive/non-flammable gas
- Hysteresis: adjustable
- Response time: ≤ 2.5 ms, with anti-vibration function
- 7-segment LCD display: 2 color (red/green) main display, orange sub-display (refresh rate: 5 times/second)
- Choice of pressure unit display: kPa, MPa, kgf/cm², bar, psi, inHg, mmHg
- Power supply voltage: 12 to 24 V DC ±10%
- Current consumption: ≤ 40 mA (without load)
- Repeatability (switch output): ≤ ±0.2% F.S. ±1 digit
- Electrical connection: M8 (4-pin)
- Degree of protection: IP40
- Operating temperature: 0 – 50 °C
- Enclosure material: PA 6.6 20%GF

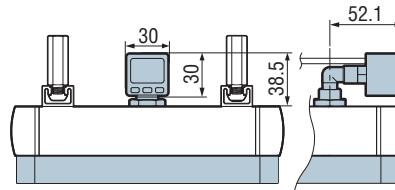

■ Option VF – vacuum gauge (VAF11140): MVG _____ X ___ VF

- Damping: by silicone movement (patented)
- Measuring: Bourdon tube in CuSn
- Precision: cl. 2.5 (+/- 2.5% of max. scale value)
- Enclosure: black ABS

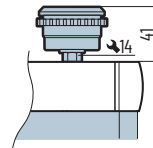

■ Option VI - IHM : MVG _____ X ___ VI

Version G0

The G0 version of COVAL MVG series vacuum grippers (with external vacuum generator) can be mounted on all types of automated or robotic systems, using M8 spacers that slide in the grooves on the aluminum profile (fastened using M8 screws).

The number of M8 spacers used depends on the vacuum gripper's size.

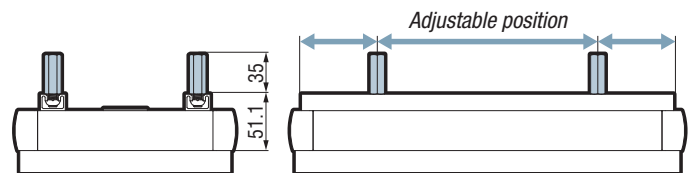
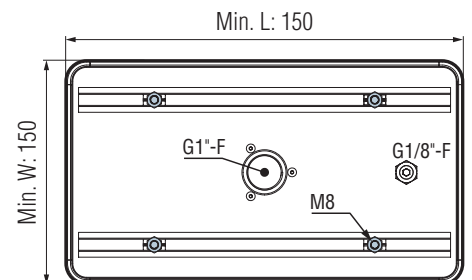

Version D1 or D2

The D1 and D2 versions of COVAL MVG series vacuum grippers (with an integrated CMS HDE series vacuum generator) can be mounted on all types of automated or robotic systems, using M8 spacers that slide in the grooves on the aluminum profile (fastened using M8 screws).

The number of M8 spacers used depends on the vacuum gripper's size.

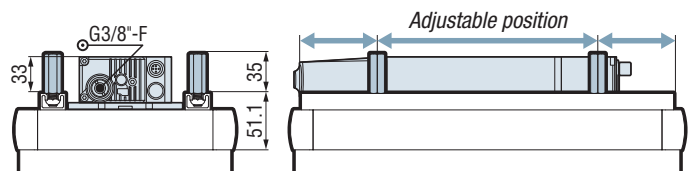
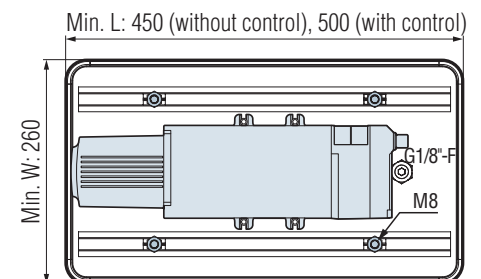

Note: all dimensions are in mm. Dimensions are indicative and may change depending on selected options.



You can access 3D files of all COVAL products in formats compatible with the main CAD software on COVAL's website www.coval.com



Version D3

The D3 version of COVAL's MVG series vacuum grippers (with two integrated CMS HDE series vacuum generators) feature adjustable M8 spacers. The number of M8 spacers used depends on the vacuum gripper's size.

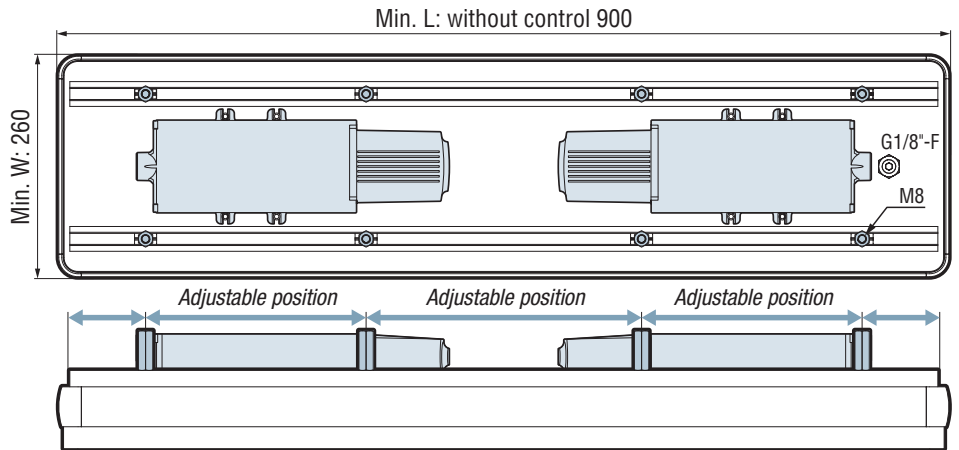
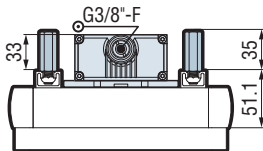

MVG Series with Suction Cup Gripping Interface

“Mini” suction cup interface

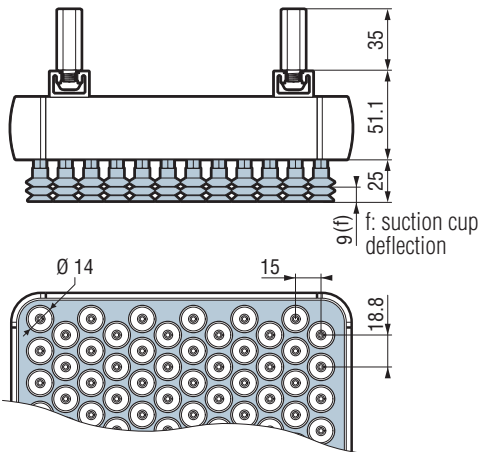

“Medium” suction cup interface

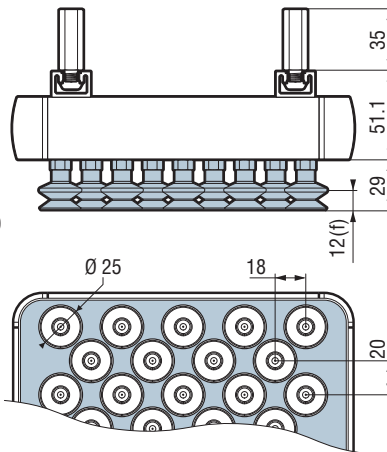

“Max” suction cup interface

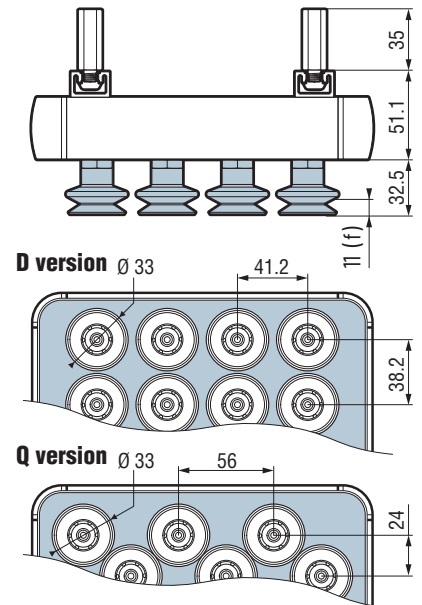

MVG Series with Foam Gripping Interface

“Mini” foam interface

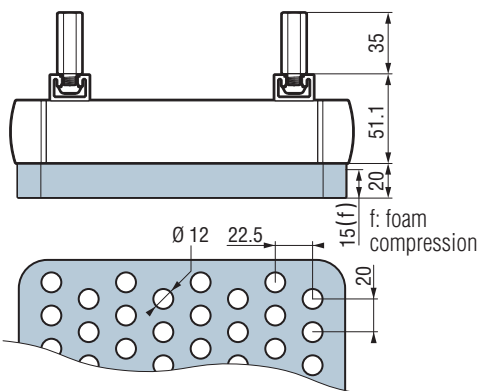

“Max” foam interface

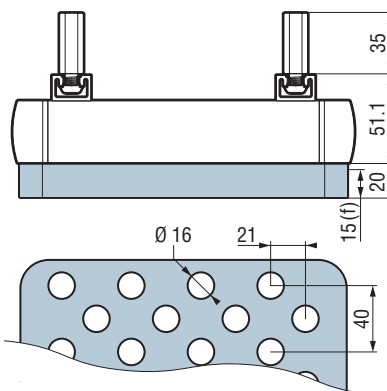

“COVAL-flex” Gripping Interface

COVAL-flex

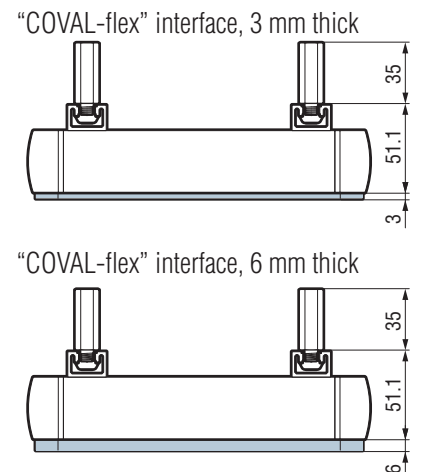

Note: all dimensions are in mm.



	MVG	...	X	...	D	VSA33JK	X		H	X	
--	------------	-----	----------	-----	----------	----------------	----------	--	----------	----------	--

LENGTH	Overall length (mm): from 150 to 1200 mm	...
WIDTH	Overall width (mm): from 150 to 1000 mm	...
GRIP PATTERN LAYOUT	Staggered	Q
	Straight*	D

* Only available for "max" suction cup interface with min. suction cup dia. of 26 mm.

	SUCTION CUP GRIPPING INTERFACES	FILTER	TECHNOLOGY
	"Mini" interface: 2.5 bellows suction cups Ø 14 mm made of 35 Shore silicone with flow control nozzles.	X Without	H Flow control nozzles
	"Medium" interface: 1.5 bellow suction cups Ø 25 mm made of natural rubber with flow control nozzles.		
	"Max" interface: 1.5 bellow suction cups Ø 33 mm made of natural rubber with flow control nozzles.		
	"Max" interface: 2.5 bellows suction cups Ø 30 mm made of 35 Shore white silicone with flow control nozzles.		

	FOAM GRIPPING INTERFACES	FILTER	TECHNOLOGY
	"Mini" interface: EPDM (20 mm thick)	X Without	H Flow control nozzles
	"Max" interface: EPDM (20 mm thick)	F With	E Airtight valves

	COVAL-flex GRIPPING INTERFACES	TECHNOLOGY
	COVAL-flex gripping interfaces are designed to meet the needs of specific applications. COVAL's sales team would be happy to provide any recommendations or further information you may require should your application be able to use any of their special	V Check valves

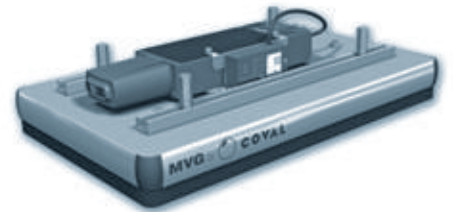

	D1	S		1		K		VA	
VERSION WITHOUT VACUUM GENERATOR			GENERATOR CONTROL		GENERATOR CONFIGURATION		EXHAUST		
Without generator	GO	N	Without	0	Without	X	Without		
VERSIONS WITH VACUUM GENERATOR*			GENERATOR CONTROL		GENERATOR CONFIGURATION		EXHAUST		
1 x CMSHDE_50 multi-stage vacuum pump Flow rate: 700 NI/min	D1	N	Without	0	Without	K	Through-type silencer		
1 x CMSHDE_100 multi-stage vacuum pump Flow rate: 1100 NI/min	D2	S*	CMSHDE__S_ Multi-stage vacuum pump with NC vacuum control and NC blow-off control. Choice of blow-off settings (only on MVG__S2_ models): <ul style="list-style-type: none"> Controlled by external signal Automatic timer from 50 to 9999 ms (advantage: saves one controller output) 	1	CMSHDE__VOC15P Controlled multi-stage vacuum pump without vacuum switch or HM <ul style="list-style-type: none"> One M12 5-pin male PNP Digital inputs/ outputs mode (SIO) 				
2 x CMSHDE_100 stage vacuum pumps Flow rate: 2200 NI/min	D3	V*	CMSHDE__V_ Multi-stage vacuum pump with NO vacuum control and NC . <ul style="list-style-type: none"> Blow-off controlled by external signal 	2	CMSHDE__VXC15X <ul style="list-style-type: none"> Controlled multi-stage vacuum pump with integrated vacuum switch and pressure sensor, without HMI One M12 5-pin configurable as PNP/NPN One M8 4-pin male for remote HMI Electronic vacuum switch Digital Output DO1 "object gripped" 24 V DC/NO Digital inputs/ outputs mode (SIO)/ IO-Link Compatible with HMI (for option VI) 				
<p>* See table: "Vacuum pump configurations by gripper length".</p> <p>* Only for D1 and D2.</p> <p>Integration of the VA, VF, and VI options depends on the gripper size and on the integrated vacuum generator(s). → To be confirmed during gripper engineering and design study.</p>									
								VACUUM LEVEL DISPLAY	
								Without	VO
								Electronic vacuum switch with display	VA
								Vacuum gauge	VF
								HMI on CMS HDE (option only compatible with versions S2 and V2)	VI

MVG

Modular Vacuum Grippers

Examples of Assembled Part Numbers



MVG200X200QF2BFHXGONOXVO

MVG vacuum gripper, 200 x 200 mm, “staggered” grip pattern layout, “max” EPDM foam gripping interface with filter, nozzles, and no integrated vacuum generator.

⚖️ 1.6 kg.

MVG500X265DVSA33JKXHXD2S1KVA

MVG vacuum gripper, 500 x 265 mm, “straight” grip pattern layout, “max” gripping interface, 1.5 bellow suction cups Ø 33 mm made of natural rubber with flow control nozzles, a CMSHDE_100 multi-stage vacuum pump, NC vacuum and blow-off control, and electronic vacuum switch with display for vacuum level display.

⚖️ 4.9 kg.

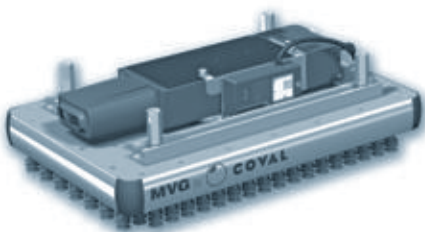
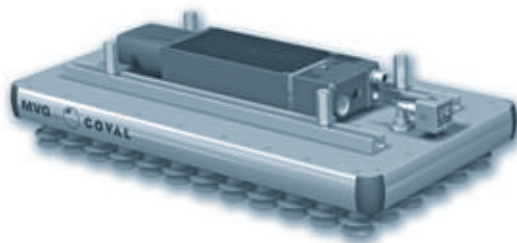

MVG380X250QVSP14BFXHXD2V2KVI

MVG vacuum gripper, 380 x 250 mm, “staggered” grip pattern layout, “mini” gripping interface, 2.5 bellows suction cups Ø 14 mm made of 35 Shore silicone with flow control nozzles, a CMSHDE_100_ multi-stage vacuum pump with NO vacuum control and NC blow-off control, vacuum switch, pressure sensor, and HMI.

⚖️ 4.9 kg.

MVG1000X400QF2SXHXD3NOKVF

MVG vacuum gripper, 1000 x 400 mm, “staggered” grip pattern layout, “mini” EPDM foam gripping interface with nozzles, CMS HDE 100 multi-stage vacuum pumps without control, and vacuum gauge for vacuum level display.

⚖️ 10.8 kg.

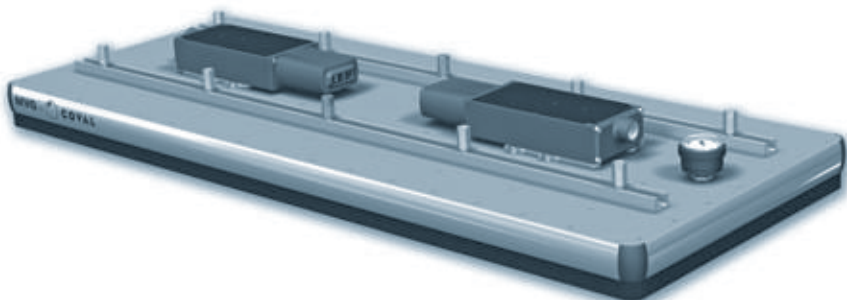

MVG

13

MVG

Modular Vacuum Grippers

Examples of Customized Versions



COVAL CUSTOMIZATION



There might be situations where the standard MVG configurations available here will not match your application requirements.



COVAL can provide customized solutions, based on your operating specifications, integrating specific functions (e.g. multi-zoning) or by suggesting a gripping interface based on the COVAL range of suction cups (a wide choice of shapes, diameters and materials) to efficiently meet all your requirements.

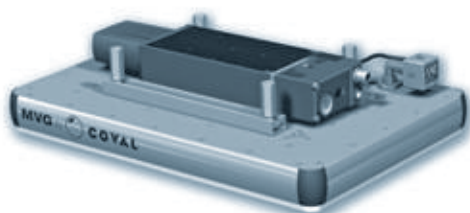

MVG410X280Z01G6XHxD2S1KVA

MVG vacuum gripper, 410 x 280 mm, “straight” grip pattern layout, 6 mm-thick COVAL-flex gripping interface with nozzles, a CMSHDE_100 multi-stage vacuum pump with NC vacuum and blow-off control, electronic vacuum switch with display for vacuum level display, and 4 through-holes for customer’s fitting requirements.
 ⚖️ 5 kg.

MVG500X500Z01CBC85HPXHxD2S2KVI

MVG vacuum gripper, 500 x 500 mm, “straight” grip pattern layout, gripping interface with C series 1.5 bellow suction cups Ø 85 mm made of nitrile with nozzles, a CMSHDE_100 multi-stage vacuum pump with NC vacuum and blow-off control, vacuum switch, pressure sensor, HMI, and an M12 bulkhead adapter for sensor.
 ⚖️ 8.5 kg.

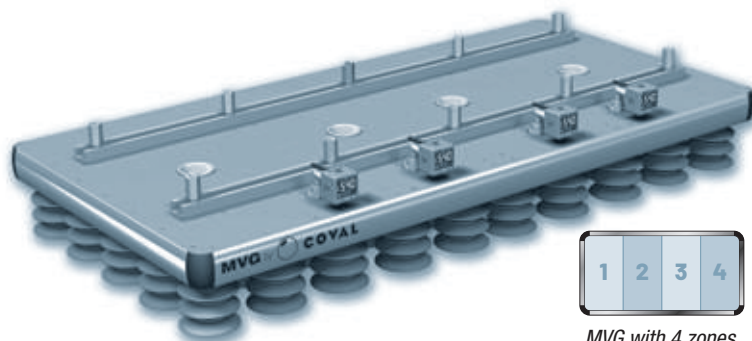
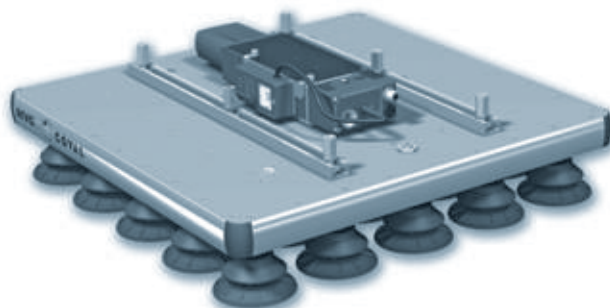

MVG with 4 zones

MVG800X400Z04VS62JNXHXGONOXVA

MVG vacuum gripper, 800 x 400 mm, “straight” grip pattern layout, gripping interface with VS series 2.5 bellows suction cups Ø 62 mm made of natural rubber with flow control nozzles, 4 independent zones equipped with an electronic vacuum switch with display, and no integrated vacuum generator.
 ⚖️ 11 kg.

MVG1200X600Z04F3BXHXGONOXVA

MVG vacuum gripper, 1200 x 600 mm, “straight” grip pattern layout, “max” 30 mm-thick EPDM foam gripping interface with nozzles, 4 independent zones equipped with an electronic vacuum switch with display, and no integrated vacuum generator.
 ⚖️ 17.8 kg.

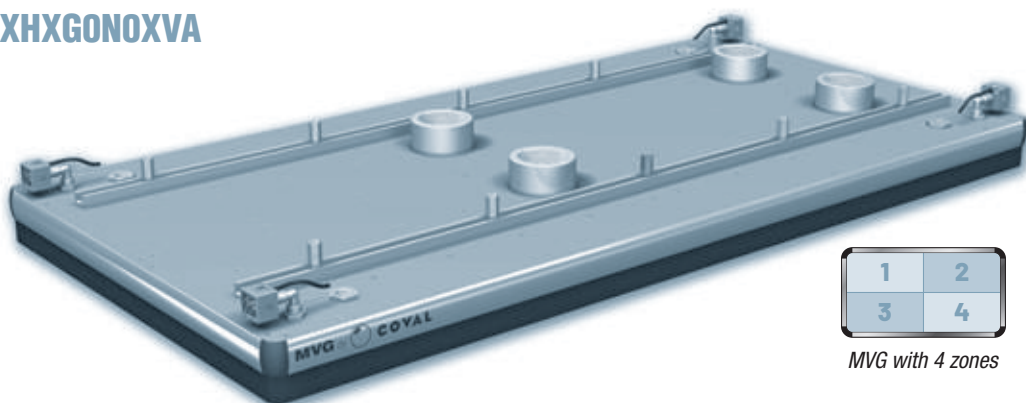

MVG with 4 zones

MVG

Modular Vacuum Grippers

Technical Specifications



General Specifications

- Operating temperature: 0 to 50 °C (32 to 122 °F)
- Material of gripper: aluminum, PA 6.6 15% GF, brass, stainless steel, neoprene
- Material of foam gripping interface: EPDM
- Materials of suction cup gripping interface:
 - Mini interface: 35 Shore silicone
 - Medium interface: 50 Shore natural rubber
 - Max interface: 50 Shore natural rubber or 35 Shore white silicone

Specifications of Multi-Stage Vacuum Pumps

- Supply: non-lubricated air, filtered to 5 microns, according to standard ISO 8573-1:2010 [3:4:4]
- Operating pressure: from 2 to 8 bar
- Optimal dynamic pressure:
 - CSMHDE_NVO (for MVG_D_NO_ grippers) without control: 5.5 bar
 - CSMHDE_S_ / CSMHDE_V_ with control (for MVG_S_/MVG_V_ grippers): 6 bar
- Pressure connection: G3/8"-F with removable 350 µm filter screen
- Max. vacuum: 80%.
- Air suction flow rate: 700 to 2200 NI/min
- Air consumption: 220 to 840 NI/min
- Noise level:
 - CSMHDE90X50_K: 59 dBA
 - CSMHDE90X100_K: 62 dBA
- Degree of protection: IP65
- Max. operating frequency: 4 Hz
- Endurance: 50 million cycles
- Materials: PA GF, brass, aluminum, steel, NBR, PU, FKM
- M12 and M8 male connectors (depending on version)

Integrated electronics

- 24 V DC power supply (regulated ±10%)
- Inputs/outputs protected against reversed wiring and polarity
- Consumption: 170 mA max. (without load)

Only on models CSMHDE_VX_ installed on MVG_S2 / V2 vacuum grippers:

- Vacuum measuring range: 0 to 99%
- Pressure measuring range: 0 to 10 bar
- Vacuum and pressure measurement accuracy: ±1.5% of the range, compensated for temperature
- Input/output switching mode: PNP or configurable as PNP/NPN
- Digital inputs/outputs mode (SIO) / IO-Link

DO1 output signal

Only on models CSMHDE_VX_ installed on MVG_S2 / V2 vacuum grippers:

- Configurable as PNP or NPN
- NO or NC
- Breaking capacity: 330 mA
- DO1: object gripped output (factory setting 40%)

Diagnostic

Only on models CSMHDE_VX_ installed on MVG_S2 / V2 vacuum grippers:

- Instantaneous vacuum level (unit transmitted over IO-Link: mbar)
- Available information: object gripped, object lost
- Cycle counters (vacuum, blow-off, object gripped, object lost, etc.)

- Supply pressure monitoring
- Supply voltage monitoring
- Product part number and serial number
- Software version

Indicator on model CSMHDE_VOC15P_ installed on MVG_S1 / V1 vacuum grippers:

- Status LED for control functions:
 - Green LED: vacuum control
 - Orange LED: blow-off control

Information displayed on HMI (option VI)

- LED gripping status indicator on front panel (green: object gripped, red: object lost)
- 1.54" high-visibility color LCD display:
 - Displays vacuum level with bar graph and thresholds
 - Warns when service life has been exceeded (> 50 million cycles)
 - Explicit fault messages
 - "Suction cup" icon indicating the status of control functions:
 - Green suction cup: vacuum control
 - Orange suction cup: blow-off control
 - Red suction cup: simultaneous vacuum and blow-off control
 - The display rotation can be configured as follows: 0 – 90 – 180 – 270°.

Parameter settings available with the HMI or IO-Link

Only on models CSMHDE_VX_ installed on MVG_S2 / V2 vacuum grippers:

- Choice of blow-off type (only MVG_S2):
 - Controlled
 - Automatic timed, adjustable from 50 to 9999 ms
- Object gripped (L1) control thresholds
- Whenever required by the application, specific threshold and hysteresis settings that are different from the initial factory settings can be defined: L1 = 40%, h1 = 10%

+ Additional parameter settings available with the HMI

(performed with 4-key membrane keypad):

- Choice of language: EN, FR, DE, IT, or ES
- Choice of vacuum measurement unit (kPa, %, mbar, inHg)
- Choice of pressure measurement unit (MPa, bar, Psi)
- Monostable electrical manual controls

Communication

IO-Link

- Revision: 1.1
- Transmission rate: COM3 – 230.4 kbit/s
- Min. cycle time: 1 ms
- SIO mode: Yes
- Process Data Input (PDI): 6 bytes
- Process Data Output (PDO): 1 byte
- IO device description file (IODD) available for download

NFC

- The COVAL Vacuum Manager mobile app is available on the following devices:
 - Android version 8.1 and higher
 - iOS version 13 and higher

MVG

Modular Vacuum Grippers

Applications



Industry-specific applications

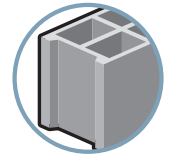
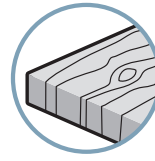
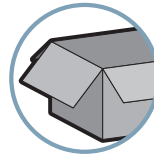
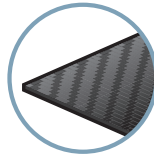
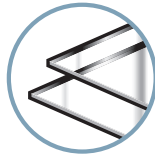
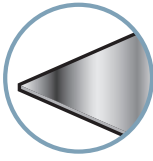
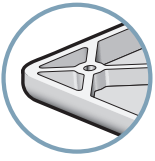

CSGS

Bags/sacks Gripping System

General information

The CSGS system is a comprehensive package that includes a specific suction pad and an optimized vacuum generator and guarantees high reliability for handling plastic or paper bags from 25 to 60 kg, used for packing powder and/or granulated products.

It is particularly recommended for robotic palletizing and de-palletizing applications that require a quick and secure implementation.

Gripping capacity:

The CSGS...X35 models are equipped with a 250x150 mm suction pad allowing them handle loads of up to 35 kg, depending on the bag's resilience. The CSGS...X60 models are equipped with a 360x190 mm suction pad and can handle loads of up to 60 kg.

Advantages

- The CSGS system is designed to support the load handled by the suction pad and thus allows it to be installed directly onto the robot's arm.
- The CSGS system allows for a quick and cost-effective installation: it is fed by a single small-sized compressed air hose, which avoids the complexity of setting up a vacuum network consisting of large pipes and vacuum valves.
- The suction pad features a foam lip that ensures the maximum flexibility required for gripping a variety of product types.
- The specific vacuum generator has been designed to provide high air intake flow rates thus allowing for shorter response times and the handling of porous products.
- It does not include any membrane and has no internal moving parts. It therefore is clog-free and can be installed without requiring any filter on the vacuum network.
- Very low noise level thanks to external silencers.
- No heat emission, vibration-free.

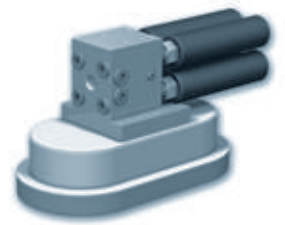

Industry-specific

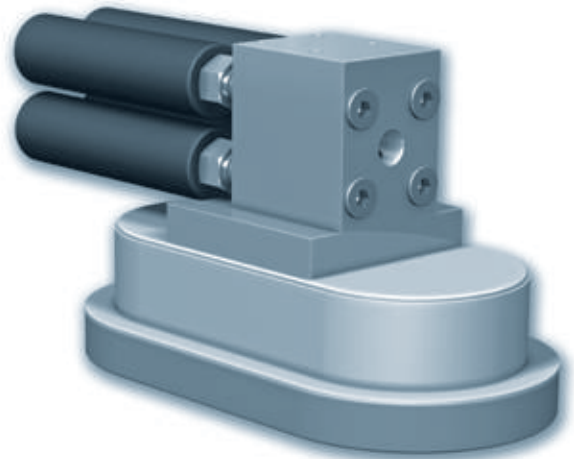
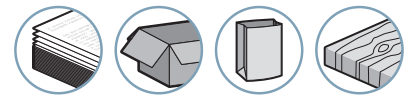

Specifications

Feed pressure	Non-lubricated filtered air 2 to 6 bar
Optimal pressure	4 bar
Weight	From 7 to 8.3 kg, depending on model
Materials	NR, aluminum, CuZn, steel
Temperature	From 10 to 50 °C

Characteristics

Model	Air consumed (NI/min)			Maximum vacuum (%)	Air drawn (NI/min)
	4 bar	5 bar	6 bar		
CSGS4X15X35	400	480	560	75	720
CSGS4X20X35	720	864	1008	75	1000
CSGS4X25X60	1080	1296	1512	84	1440
CSGS4X30X60	1600	1920	2240	84	1800



Please specify model, e.g.: CSGS4X15X35
Refer to characteristics table above

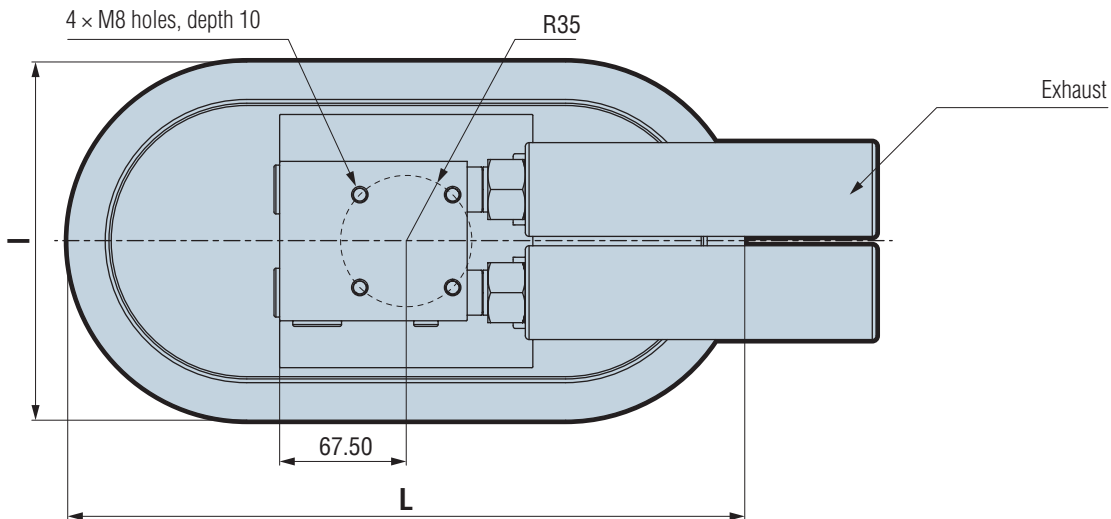
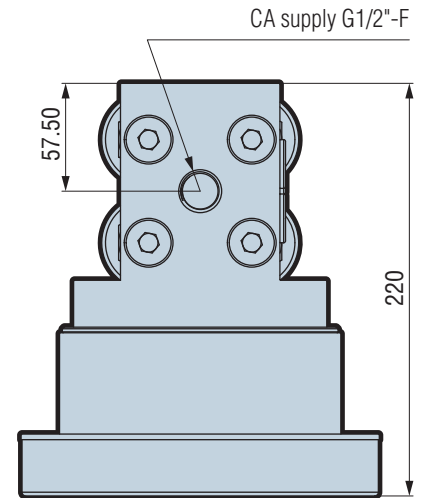
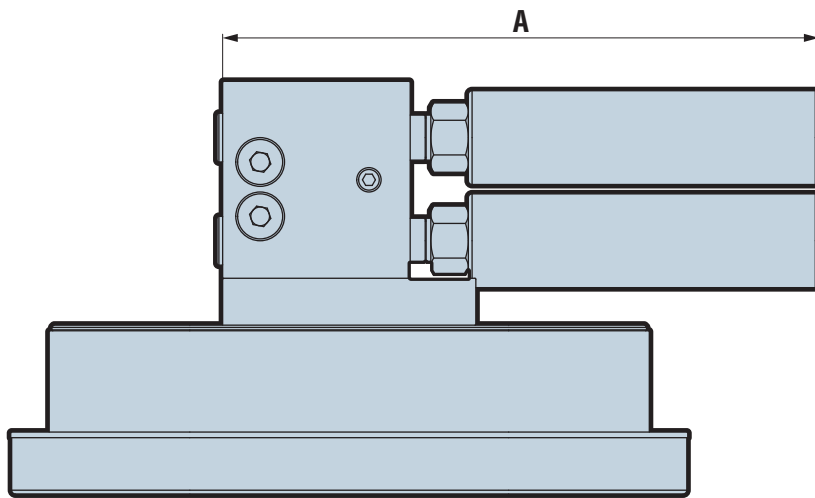

Model	L	I	A	Silencer
CSGS4X15X35	250	150	229	SILK12C
CSGS4X20X35	250	150	229	SILK12C
CSGS4X25X60	360	190	318	SILK34C
CSGS4X30X60	360	190	390	SILK34C

All dimensions are in mm.

Peripheral Devices

Chapter 14

VRU

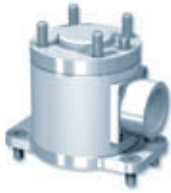

Vacuum Rotary Union

- Connection: G3/4"-F
- Mounting interface: ISO 9409-1-50-4-M6
- Flow Rate: 1500 NI/min
- Compact and lightweight
- Excellent mechanical resistance
- Continuous rotation
- Ideal for cobotic

P_{14/2}

VRS



Vacuum Rotary Connection

- Connection: G3/4"-F
- Flow Rate: 1500 NI/min
- Maximum speed: 40 tr/min
- Compact and lightweight
- Excellent mechanical resistance
- Continuous rotation
- Ideal for cobotic

P_{14/3}

NVS NVR NVA



Vacuum Feeders

- Vacuum feeders, 1 input, 4 to 8 outputs
- NVS: Screwed feeder fittings
- NVR: Push fitting feeder fittings
- NVA: Threaded aluminum feeder
- Facilitates optimum vacuum management by improved distribution
- Eliminates air pressure loss
- Simplifies connection
- Less time-consuming installation
- Compact and lightweight

P_{14/4}

RDV RCOV Y



Screwed Vacuum Fittings with O-ring

- RDV, RCOV and RY series: Straight, adjustable elbow or Y fitting
- Diameter options: 5.5/8, and 6/8, 7/10, 8/10, 1 0/12
- Gas fittings options: 1/2", 1/4", 1/8", 3/8"
- 100% vacuum-tight
- Integrated O-ring
- Improved circuit sealing
- Can be removed and reinstalled without requiring preparation of the tubing

P_{14/5}

RVM RVF RVT TVR COV



Fittings, Vacuum Tubes, Collars

- Rigid tubes allow a vacuum network to be installed with no pressure loss
- Barbed fittings guarantee a rigid connection between the source and the vacuum tube
- Collars used on TVR type pipes to guarantee network sealing

P_{14/6}

REV 38



Vacuum Regulator

- Adjustment precision: 3.4 mbar
- Materials used in the VITON body and lacquered aluminum foundry
- Adjustment by threaded pin
- G3/8" fitting attachment bracket
- Direct connection to a vacuum pump
- Very fine adjustment

P_{14/7}

AG



Vacuum Valves, 3 channels

- Connection to the vacuum network
- Electric control
- Voltage: 12 VDC, 24 VDC or VAC, 110 VAC, 220 VAC
- NO or NC for the vacuum or compressed air supplied servo
- Facilitates vacuum or compressed air network management
- NO or NC option allows adaptation to suit the application

P_{14/8}

PA



Angular Jaw Clamps

- Adjustment of finger speed with compressed air regulator
- 3 models
- For use on all types of manipulators
- Recommended for injection press unloading robots for parts or sprue

P_{14/10}

VRU

Vacuum Rotary Union

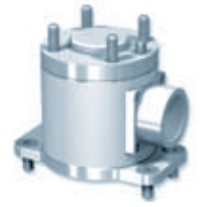

The VRU Series Vacuum Rotary Union, with its robust and lightweight design, provides a direct connection between the robot and the gripper, while also allowing an external vacuum supply to the gripper.

Its continuous rotation system avoids coiling of the hose and eliminates force constraints when used with collaborative robots.

Industry-specific applications



Advantages

- Compact and lightweight
- Excellent mechanical resistance
- Easy integration: Mounting interface: ISO 9409-1-50-4-M6
- Continuous rotation
- Ideal for cobotic

Characteristics

Model	Flow Rate (NI/min)	Connection	Weight (g)
VRU34A50	1500	G3/4"-F	440

Specifications

Materials	Steel - Aluminum - POM - Brass - NBR Nitrile
Temperature range	From -10 to +50°C

Dimensions

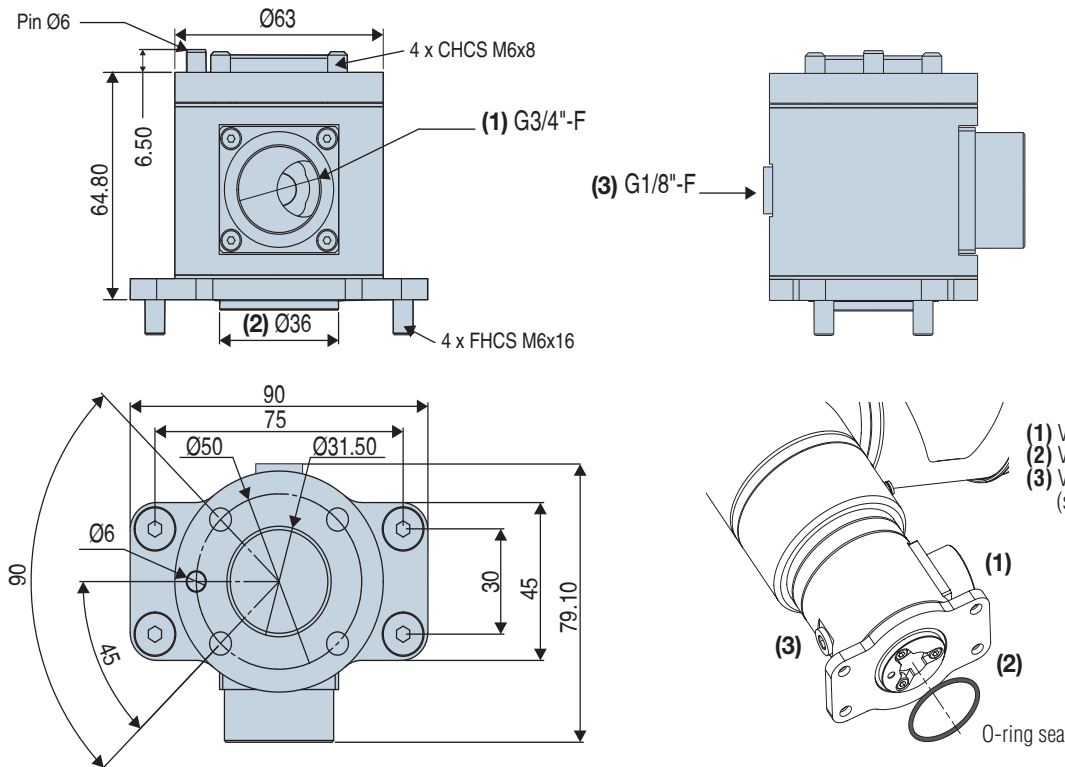

Note: All dimensions are in mm.
The values represent the average characteristics of our products.



To order please specify: VRU34A50

Accessory

G3/4" on-line rotating seal, part n° VRS34MF

VRS

Vacuum Rotary Connection



The VRS Series Vacuum Rotary Connection, with its robust and lightweight design, provides an in line rotary connection for vacuum supplies. Its continuous rotation system avoids coiling of the hose and eliminates force constraints when used with collaborative robots.

Industry-specific applications



Advantages

- Compact and lightweight
- Excellent mechanical resistance
- Continuous rotation
- Ideal for cobotic

Characteristics

Model	Flow Rate (Nl/min)	Through bore Ø (mm)	Maximum speed (tr/min)	Connection	Weight (g)
VRS34MF	1500	16	40	G3/4"-M/F	135

Specifications

Materials	Aluminum - NBR Nitrile - Steel
Temperature range	From -10 to +50°C

Dimensions

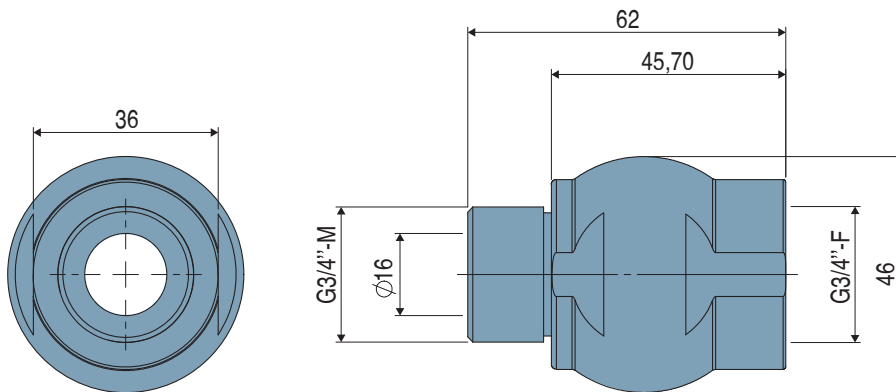

VRS

Note: All dimensions are in mm.
The values represent the average characteristics of our products.



To order please specify: VRS34MF

Accessory

Vacuum Rotary Union part n° VRU34A50

14

NVS, NVR, NVA

Vacuum Feeders



The NVS and NVR series vacuum feeders enable distribution of the vacuum in 4 to 8 channels by a simple unit. The 8/10 inputs and 4 or 8 6/8 outputs eliminate pressure loss.

Characteristics

		Screwed vacuum fittings		Push fittings		Threaded
Models		NVS 4	NVS 8	NVR 4	NVR 8	NVA 4
Material	Body	PA 6.6 – 30 % fiber glass, black, ULV094				Aluminium 2014 A
	fitting	Nickel-plated brass		PA		
For tube		calibrated polyamide or polyurethane (PUR)				4 x G1/4"-F and 1 x G3/8"-F
Vacuum		■ ++	■ ++	■	■	■ ++
Pressure (up to 10 bar max.)		-	-	■	■	■

■ ++ Recommended for vacuum networks with regulation

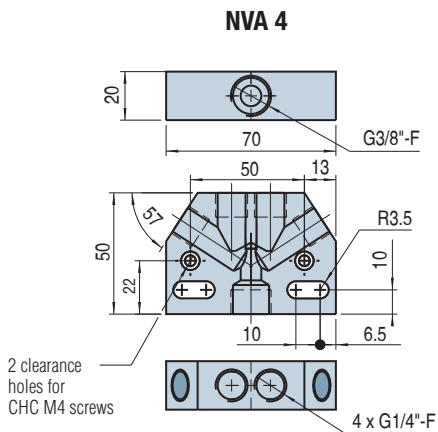
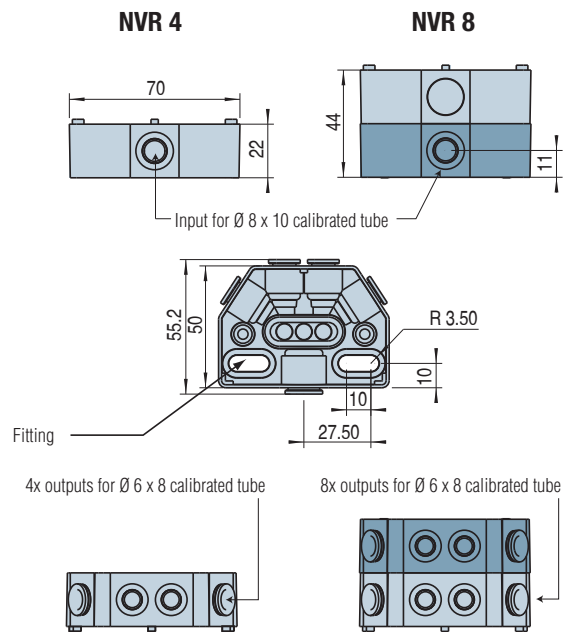
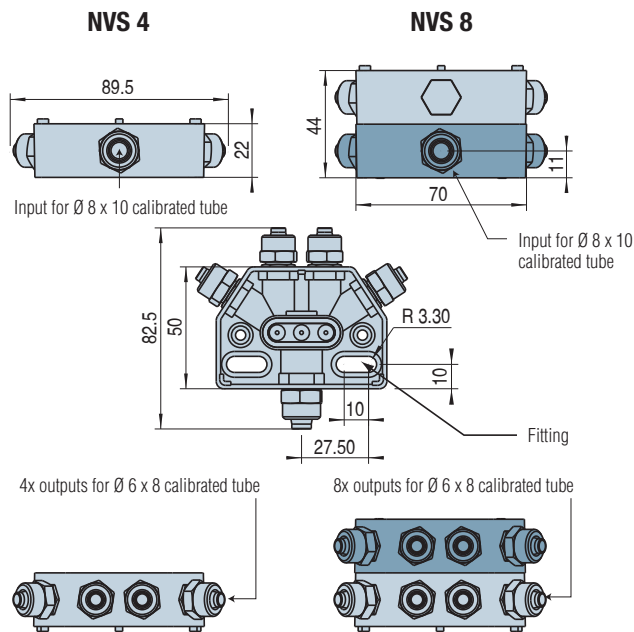

For all orders, please specify:
Model + Type + Number of outlets
e.g.: NVS8

1: Model	2: Type	3: Number of outlets
NV	S	screwed fittings
	R	push fittings
	A	threaded

Note: All dimensions are in mm

Note: for NVA series, one reference only: NVA4

RDV, RCOV, Y

Screwed Vacuum Fittings with O-ring



Characteristics

Range of special vacuum-tight fittings, fitted with O-ring (blue).

- 100% vacuum-tight and improved circuit sealing
- Can be removed and reinstalled without requiring preparation of the tubing
- Adjustable fittings for improved vacuum distribution
- Material: nickel-plated brass

RDV Series Straight Fitting

Ref.	ØA	F	CH	CH1	P	L
RDV1868	6/8*	G1/8"-M	14	14	6	26
RDV1468	6/8*	G1/4"-M	17	14	8	29
RDV14810	8/10	G1/4"-M	17	16	9	30.5
RDV3868	6/8*	G3/8"-M	19	14	9	30.5
RDV38810	8/10	G3/8"-M	19	16	9	32
RDV38812	8/12	G3/8"-M	19	19	9	32.3
RDV12810	8/10	G1/2"-M	24	16	10	33.5
RDV381012	10/12	G3/8"-M	19	19	9	32.3
RDV12812	8/12	G1/2"-M	24	19	10	34.5
RDV121012	10/12	G1/2"-M	24	19	10	34

* 6/8 fittings are 5.5/8 compatible.

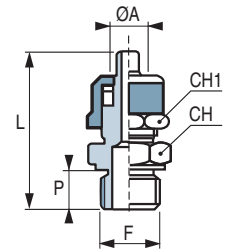

RCOV Series Elbow Fitting

Ref.	ØA	F	CH	CH1	CH2	P	L	L1
RCOV1868	6/8*	G1/8"-M	10	14	14	7	24	22
RCOV1468	6/8*	G1/4"-M	13	14	17	9	28.5	27.5
RCOV14810	8/10	G1/4"-M	13	16	17	9	28.5	28
RCOV3868	6/8	G3/8"-M	13	14	22	9	29	27.5
RCOV38810	8/10	G3/8"-M	13	16	22	9	29	28
RCOV12810	8/10	G1/2"-M	17	16	26	10	35	34
RCOV121012	10/12	G1/2"-M	17	19	26	10	35	34

* 6/8 fittings are 5.5/8 compatible.

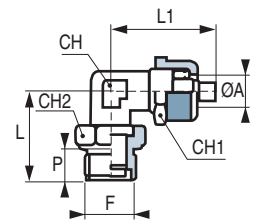

Y Fitting, Y Series

Ref.	ØE	ØS
Y68	6/8*	6/8*
Y810	8/10	8/10
Y81068	8/10	6/8
Y812	8/12	8/12
Y81268	8/12	6/8
Y1012	10/12	10/12
Y1012810	10/12	8/10

* 6/8 fittings are 5.5/8 compatible.

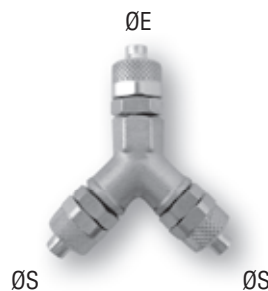

RVM, RVF, RVT, TVR, COV

Fittings, Vacuum Tubes, Collars

Fittings RVM, RVF, RVT

Barbed fittings used to connect the vacuum source to the vacuum tube to guarantee a rigid connection.

Material: **brass**

Models	D	D1	D2	d*
RVM 1014	G1/4"-M	-	-	10
RVM 1038	G3/8"-M	-	-	10
RVM 1538	G3/8"-M	-	-	15
RVM 1512	G1/2"-M	-	-	15
RVM 2012	G1/2"-M	-	-	20
RVM 2034	G3/4"-M	-	-	20
RVF 1038	G3/8"-F	-	-	10
RVF 1512	G1/2"-F	-	-	15
RVF 2034	G3/4"-F	-	-	20
RVT 1012	-	G1/2"-F	G3/8"-M	10
RVT 1534	-	G1/2"-F	G3/4"-M	15

(*) Inside diameter of the suitable pipe

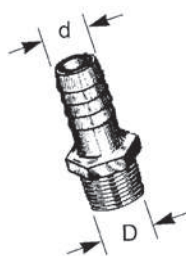

RVM

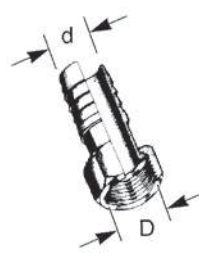

RVF

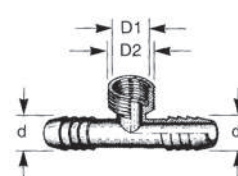

RVT

Vacuum Tubes TVR

Thanks to their rigid design and steel coil, they ensure there is no pressure loss on the vacuum network.

Colour: **Crystal**

Models	inside Ø	outside Ø	r*
TVR 10	10	16	18
TVR 15	15.5	22.5	30
TVR 20	19.5	27.5	37

*r: minimum curve fitting

TVR vacuum tubes hold a 90% vacuum with an ambient temperature of 30°C.

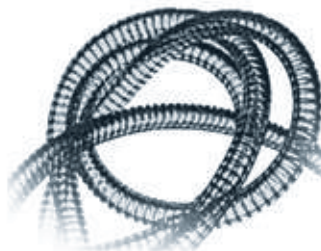

Collars COV

Accessory to be used for attaching TVR type pipes to guarantee perfect sealing.

Material: **stainless steel**

Models	Tube réf.	L
COV 10	TVR 10	7
COV 15	TVR 15	7
COV 20	TVR 20	7

Other dimensions and shapes on request.



Note: All dimensions are in mm

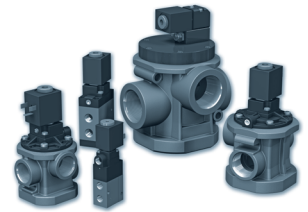

The **3-channel AG vacuum valves** are designed to optimize vacuum networks, offering increased efficiency in various applications. Available in configurations with vacuum or compressed air supplied servos, and in normally open or closed modes, they offer flow rates ranging from 1.5 to 180 m³/h and various control voltages, thus meeting diverse industrial needs.

NC vacuum supplied servo

- 1: Pump
- 2: Use
- 3: Exhaust

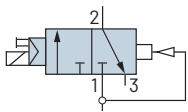

NC C.A. supplied servo

- 1: Pump
- 2: Use
- 3: Exhaust

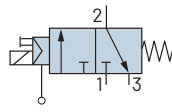

NO vacuum supplied servo

- 1: Pump
- 2: Use
- 3: Exhaust

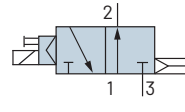

NO C.A. supplied servo

- 1: Pump
- 2: Use
- 3: Exhaust

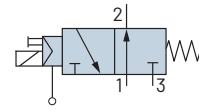

Characteristics and Dimensions

Ref. NO C.A. servo	Ref. NC C.A. servo	Ref. NO Vacuum servo	Ref. NC Vacuum servo	Ø R	Diagram	A	B	C	D	E	F	G	H	I	J	K	L	Ø M*	Ø N
AG 3002	AG 3001	-	-	G1/8"-F	1	111	55.5	22.5	9.7	-	20.2	35	28	22	10.5	18	-	G1/8"-F	4.5
AG 3010	AG 3009	AG 3211	AG 3210	G1/4"-F	1	140.2	77.5	36	22.5	23	34	59	40	32	24	23.5	-	M5-F	4.5
AG 3012	AG 3011	AG 3215	AG 3214	G3/8"-F	1	140.1	77.5	36	24.5	23	36	59	40	32	24	23.5	-	M5-F	4.5
AG 3021	AG 3020	AG 3223	AG 3222	G1/2"-F	2	148	100.3	78.5	75	63	53.5	20	30	50.5	35	41	46.5	M5-F	6.5
AG 3041	AG 3040	AG 3233	AG 3232	G3/4"-F	2	147.9	100.3	78.5	75	63	53.5	20	30	50.5	35	41	46.5	M5-F	6.5
AG 3051	AG 3050	AG 3243	AG 3242	G1"-F	2	164.7	117.1	100	95	76	62.5	25.5	38	64	44.7	51	60.3	M5-F	9
AG 3063	AG 3062	AG 3257	AG 3256	G1 1/2"-F	3	202	152	158	138	113	113	34	68	96	59	68	84	G1/8"-F	11

* Only available on Servo A.C.

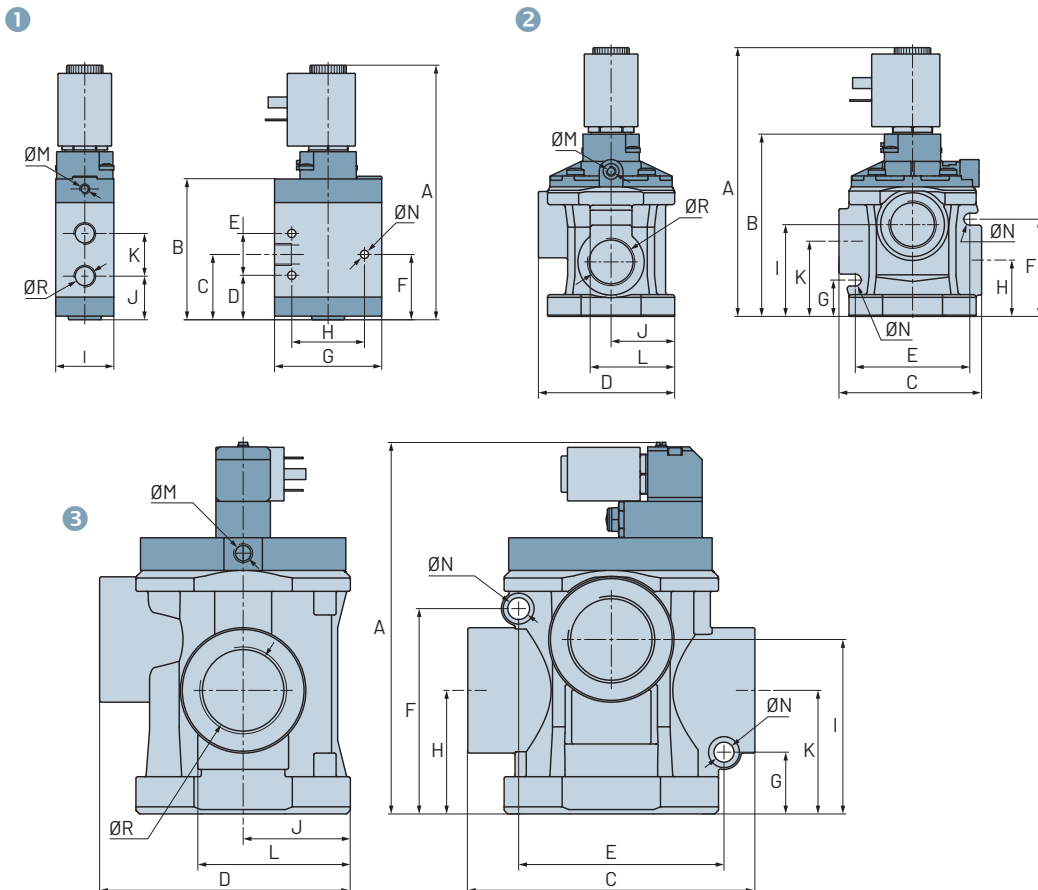

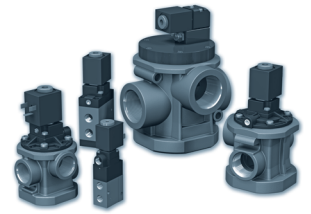

Specifications

Fluid	Non-lubricated 50 micron filtered air. If lubrication is used it must be uninterrupted	
Maximum vacuum	97 %	
Operating temperature	-20 °C to 40 °C / -4 to 104 °F	
Fluid temperature	Max 40 °C	
Dynamic seal	Polyurethane	
Static seal	NBR	
Coil power	11 VA	10 VA
Voltage	12 VDC / 24 VDC	24 VAC / 110 VAC / 220 VAC
Minimum vacuum for vacuum supplied servo	20 %	

Characteristics

Fitting	G1/8"	G1/4"	G3/8"	G1/2"	G3/4"	G1"	G1 1/2"
Nominal diameter [mm]	5.5	8	10	15	19	25	39
Flow rate [m ³ /h]	1.5	4	10	20	35	90	180
Response time (activation) ⁽¹⁾	15	18	18	20	20	20	60
Response time (deactivation) ⁽¹⁾	25	28	28	40	40	45	40
Minimum control pressure (bar) for C.A. servo	1.5	2.5	2.5	3	3	3	4
Weight (g)	195	552	540	816	778	1214	3456

(1) with monostable electrical control

Voltage code

Code	E1	E2	E3	E4	E5	E7
Voltage	24 VDC	220 VAC	24 VAC	110 VAC	48 VAC	12 VDC

Note: All dimensions are in mm



For all orders, please specify:
Model + Voltage
e.g.: AG3215E1

Angular Jaw Clamps

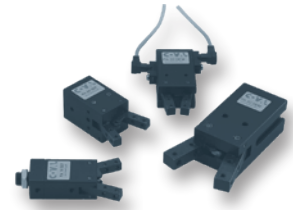

The PA series angular jaw clamps are used in robotics and the plastics industry and more generally on all types of manipulators. They are particularly recommended for use on injection press unloading robots.

Choose a clamp with a theoretical force $Coval$ to at least twice the effective force required.

The clamping forces in the table above are theoretical forces and are given for a pressure of 6 bar. Gripping force is inversely proportional to the distance between the gripping point and the fulcrum.

For example, for a PA 20 clamp with the gripping point 25mm from the fulcrum, the clamping force will be:

$$F = 10.1 \text{ (table below)} \times 15/25 = 6.06 \text{ kg.}$$

The weight of the objects to be handled is added to that of the clamp and must not exceed 1/20th of the force exerted on the gripping point.

The opening and closing speed of the fingers can be adjusted with the compressed air regulator.

- **DE:** double action clamp using compressed air.
- **SEF:** closure by compressed air, opening by return spring (simple closing effect).
- **SEO:** opening by compressed air, closure by return spring (simple opening effect).

Characteristics

Models	Clamping force(kg)	Min. pressure (bar)	Weight (g)	Magnetic sensor option
PA 16 SEF	4	2.5	120	-
PA 16 SEO	5.2	2.5	120	-
PA 16 DE ⁽¹⁾	5.5 to 6.5	1.5	120	-
PA 20 SEF	7.5	2	190	yes
PA 20 SEO	8.5	2	190	yes
PA 20 DE ⁽¹⁾	10.1 to 12.2	1.2	190	yes
PA 32 SEF	16.5	1.8	490	yes
PA 32 SEO	19.5	1.8	490	yes
PA 32 DE ⁽¹⁾	22 to 24	1	490	yes
PA 50 DE ⁽¹⁾	52 to 60	0.8	1660	yes

(1) The clamping force above is given in bar at a distance of 15 mm from the fulcrum for models PA 16 - 20 - 32 and 30 mm from the fulcrum for models PA 50.

Specifications

Compressed air	Filtered, lubricated or non-lubricated
Maximum pressure	10 bar
Material	Anodized aluminum
Seal	Nitrile (NBR)
Heat treatment	On and fingers
Operating temperature	-10 to 70 °C / 14 to 158 °F



For all orders, please specify:
Model + Action + Magnetic sensor
 e.g.: PA20SEOM

1: Model	2: Actions	3: Magnetic sensors
PA 16 to PA 50	SEF Simple closing effect SEO Simple opening effect DE Double action	- Without M For PA 20 - 32 - 50

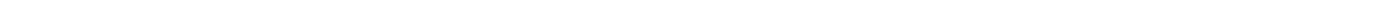

Alphabetical index

A	
AG	
Vacuum Valves, 3 channels	14/8
B	
BM	
Foam Strips	4/14
C	
C	
High-performance Suction Cups	2/59
CBP	
Pilot Control Cartridge	6/16
CC	
Screw-type Electrical Connectors M8 and M12	11/12
CD	
Screw-type Electrical Connectors M8 and M12	11/12
CMS HD	
Heavy Duty Multi-stage Vacuum Pumps	8/65
COV	
Collars	14/6
CSGS	
Bags/sacks Gripping System	13/42
CSP	
Piloted Safety Valves	4/13
CTC	
High-Performance Bell-type Suction Cups	2/63
CVGC	
Carbon Vacuum Grippers for Collaborative Robots	13/2
CVGL	
Compact and Light Vacuum Grippers	13/6
CVP	
Vacuum Cartridges	6/8
CVPC	
Controlled Vacuum Cartridges	6/12
F	
Flow Control Fittings	4/10
FPC	
FlowPack Suction Cups	3/4
FSLI	
Liquid Separator Vacuum Filters	11/10
FVG	
Mini Vacuum Filters	11/8
FVI	
Vacuum Filters	11/5
FVL 12	
In-line Filter	11/9
FVL 68	
In-line Vacuum Filter	11/9
FVUG	
In-line Filters	11/7
FVUM	
In-line Filters	11/7
G	
GEMP	
Simple Vacuum Pumps with ASR	7/8
GVEC	
"Easy Clean" Vacuum Pumps	7/11
GVMAX HD	
Heavy Duty Communicating Vacuum Pumps	8/51
GVP	
Vacuum Pumps	7/2
GVR 09, 10, 12, 14	
Micro Ejectors	6/6
I	
IMU	
Axial Ball-joints	4/12
L	
L	
Mounting Extensions	4/8
LEM	
Integrated Mini-Vacuum Pumps with "ASR"	8/3
LEM+	
Compact, High Flow Vacuum Pumps with "ASR"	8/39
LEMAX	
Integrated Mini Vacuum Pumps with "ASC"	8/11
LEMAX IO	
Mini Vacuum Pumps with Communication IO-Link	8/19
LEMAX+	
Compact, High Flow Vacuum Pumps with "ASC"	8/45
LEMCOM	
1 st Mini Vacuum Pump on Industrial Fieldbus	8/27
LEMP	
Mini Vacuum Pumps without control with ASR	7/14
M	
M--C	
Air Amplifiers	9/2
MD	
Air amplifiers	9/5
MS	
Quick Release Devices	11/4
MVG	
Modular Vacuum Grippers	13/24
MVP	
Suction Cups with 4.5 Bellows	3/10

Alphabetical index

MVS Soft Suction Cups for High Speed Applications	3/7	RVM Fittings	14/6
N		RVT Fittings	14/6
NVA Vacuum Feeders	14/4	S	
NVR Vacuum Feeders	14/4	SIL GV Diffuser Type Silencer	11/11
NVS Vacuum Feeders	14/4	SIL K--C Through-type Silencer	11/11
P		SPL Heavy Load Suction Cups	3/37
PA Angular Jaw Clamps	14/10	STEEL Steel Suction Cups with Bonded Seal	3/38
PMG2 Mechanical Feelers	4/11	T	
PSA 100 C Electronic Vacuum Switch with Display	12/4	TCL Side-channel Blowers, single-stage and two-stage	10/6
PSD 100 Vacuum Switch with 3-colour Display	12/5	TS Level Compensators	4/4, 4/5
PSE 100 E Electric Vacuum Switch	12/9	TS 11 Level Compensators	4/3
PSE 100 P Pneumatic Vacuum Switch	12/10	TSOG Anti-Rotation Level Compensators	4/7
PSE 100 PK Pneumatic Vacuum Switch	12/11	TSOP Anti-Rotation Level Compensators	4/6
PSK Mini Vacuum Switch	12/3	TVM Pipes for Air Amplifiers	9/6
PSP 100 Electronic Vacuum Switch	12/7	TVR Vacuum Tubes	14/6
PSP 100 ANA Electronic Vacuum Switch Analogue Output	12/8	V	
PVS Dry vane vacuum pumps	10/2	VAF 111 Vacuum Gauge	12/12
Q		VBO Suction Cup for Bottle Handling via the Punt	3/27
QR Diffuser-type Silencers	11/3	VP Flat Suction Cups Ø 8 to 75 mm	2/3
R		VPA Suction Cups for Paper Applications	3/29
RCOV Screwed Vacuum Fittings with O-ring	14/5	VPAG Rounded Suction Cups	3/34
RDV Screwed Vacuum Fittings with O-ring	14/5	VPAL Suction Cups for Labels	3/31
REV 38 Vacuum Regulator	14/7	VPBO Coupler Plates for gripping bottles by the punt	3/28
RSC Multi-Compensator Systems	4/5	VPF Flat Suction Cups with Cleats Ø 15 to 50 mm	2/20
RVF Fittings	14/6	VPG Extra-Flat Suction Cups Ø 2 to 200 mm	2/9

Alphabetical index

VPO Oblong Flat Suction Cups	2/23	VSE Suction Cups for Bakery Applications	3/15
VPR Suction Cups for Mailing Applications	3/33	VSG Suction Cups with 2.5 Bellows Ø 5 and 7 mm	2/53
VPSC Ultra-Flat, Non-Marking Suction Cups	3/35	VSO Suction Cups for Egg-handling	3/17
VPU Flat Suction Cups Ø 6 to 50 mm	2/17	VSP Suction Cups for Bakery Applications	3/15
VPYR Radial Ball-joint Suction Cups	3/36	Y Y Screwed Vacuum Fittings with O-ring	14/5
VR 05, 07, 09 Heavy-duty In-line Ejectors	6/2		
VR 10, 12, 14 Ejector Fittings	6/4		
VRS Vacuum Rotary Connection	14/3		
VRU Vacuum Rotary Union	14/2		
VS Suction Cups with 2.5 Bellows Ø 5 to 88 mm	2/47		
VSA Suction Cups with 1.5 Bellows Ø 5 to 78 mm	2/27		
VSAB Suction Cups with 1.5 Bellows Ø 5 to 50 mm	2/33		
VSAF Suction Cup for Cheese	3/13		
VSAG Suction Cups with 1.5 Bellows Ø 10 to 150 mm	2/37		
VSAJ Suction Cups with 1.5 Bellows Ø 15 to 30 mm	2/43		
VSAOF Oblong Suction Cup for Cheese	3/14		
VSAPL Suction Cups with 1.5 Bellows for Labels	3/32		
VSA-VS BM Suction Cups with Foam Ring Seals	2/65		
VSA-VS-BM-SIF Suction Cups with Foam Ring Seals	2/67		
VSBM Foam Rings	2/68		
VSBO, VSBO+ Suction Cups for Bottle Handling	3/18		
VSBO LM/BM Suction Cups for Bottle Handling	3/24		
VSD Long Stroke Suction Cups	2/55		
Suction Cups for Bakery Applications	3/15		

Learning Material

Test Case



Vacuokit 1 *Standard*

More information 



Vacuokit 3 *Food Industry*

More information 

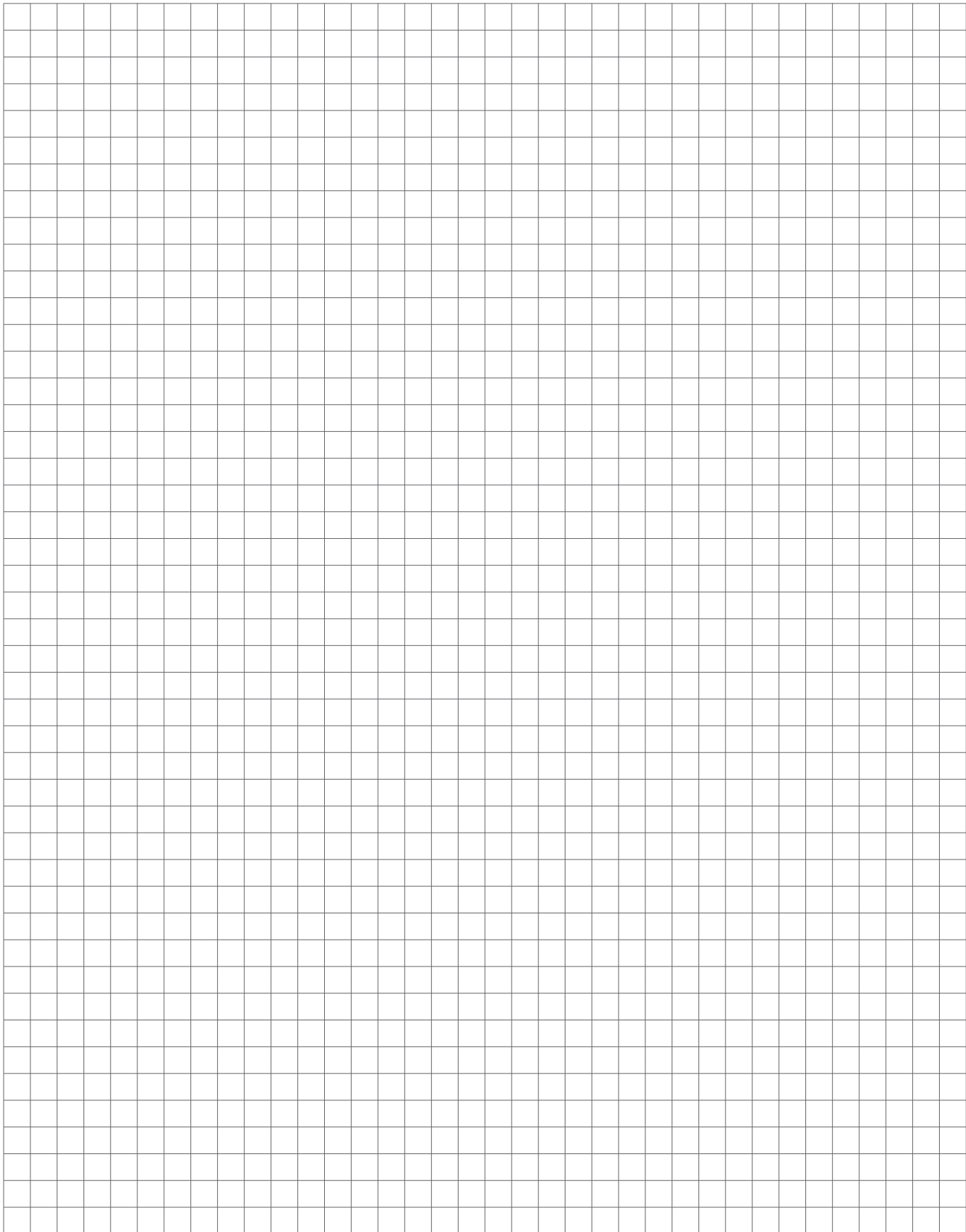

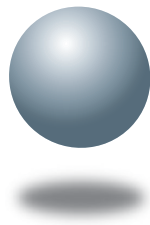

COVAL
vacuum managers



CONTACTS



► COVAL FRANCE

COVAL S.A.S.

Head Offi
ZA Les Petits Champs
10 allée Jean-Baptiste Venturi
26120 Montélier
France
Tel : +33 (0)4 75 59 91 91
www.coval.com



► COVAL INC.

COVAL VACUUM TECHNOLOGY INC.

901 Jones Franklin Road
Suite 100
Raleigh, NC 27606
U.S.A.
Phone: (919) 233-4855
www.coval-inc.com



► COVAL GERMANY

COVAL VAKUUMTECHNIK GMBH

Hohenloher Str. 6
72768 Reutlingen
Deutschland
Fon: +49 (0)7121 7999-250
www.coval-germany.com



► COVAL IBERICA

SISTEMAS DE VACÍO COVAL, S.L.

c/ Coroleu, 61-63 local 1
08030 Barcelona
España
Tel.: + 34 930 185 441
www.coval-iberica.com



► COVAL ITALIA

COVAL ITALIA S.R.L A SOCIO UNICO

Via Ferrero, 112
10098 - RIVOLI (TO)
Italia
Tel: +39 011 958 8660
www.coval-italia.com



► COVAL CHINA

**COVAL VACUUM TECHNOLOGY (SHANGHAI)
CO., LTD.**

NO.12 of Building 1, Hangdu Road NO.18,
Pudong New District,
Shanghai 201317 CHINA
Tel: +86 21 64295600
www.coval.net.cn



- A broad network:
- + 25 authorized **DISTRIBUTORS in FRANCE**
- + 40 authorized **DISTRIBUTORS outside FRANCE**

- Visit the following section on our **WEBSITE:**
Contact – Sales network,
to view the latest **UP-TO-DATE LIST**





COVAL
vacuum managers

COVAL

A TECHNOLOGICAL PARTNER ON A GLOBAL SCALE

Located in the southeast region of France, COVAL conceives, manufactures and globally distributes high performance, advanced vacuum automation components and systems for industrial applications in all branches.

COVAL is an ISO 9001:V2015 certified company which offers innovative solutions integrating reliable and optimized components with intelligent functionalities. The focus is to provide the most personalized and economic solution to a given application while assuring a significant improvement in the productivity and the safety for the vacuum users around the world.

COVAL has an ambition for technical excellence and innovation. As a specialist in vacuum automation, COVAL is reputed for offering reliable, personalized, cost effective and productive solutions.

The references of COVAL can be found in several industrial sectors (Packaging, Food Industry, Automotive, Plastics, Aeronautics...) where vacuum handling is important for high efficiency and productivity.

COVAL markets its products and services all over Europe, in the United States and South America through its subsidiaries and authorized distribution network. COVAL strives to provide customer driven solutions and gives the best possible treatment to satisfy all its clients.

For all enquiries from Australia, Africa and Asia kindly contact COVAL head office in France.



COVAL S.A.S.
Head Offi



COVAL INC.



COVAL IBERICA



COVAL GERMANY



COVAL ITALIA



COVAL CHINA

Distributed by:



Certified Quality Management System

COVAL S.A.S.

Head Offi
ZA Les Petits Champs
10 allée Jean-Baptiste Venturi
26120 Montélier - France

Tel : +33 (0)4 75 59 91 91

www.coval.com