

COVAL

vacuum managers

VACUUM HANDLING SOLUTIONS FOR THE AEROSPACE INDUSTRY

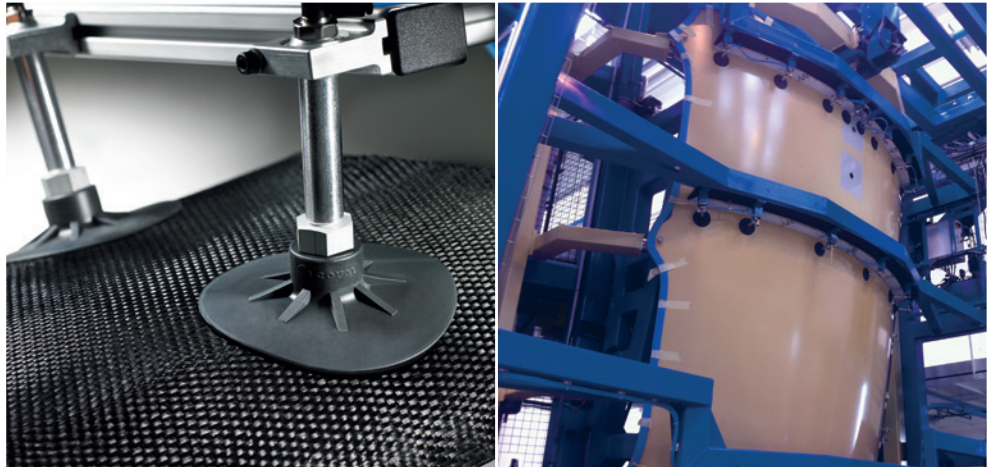

vacuum
management

ADVANCED VACUUM SOLUTIONS

www.coval.com

EN4

Vacuum Managers

At COVAL our goal is to contribute to the performance and safety of industrial processes by vacuum handling objects of all sizes, weights, and materials.

COVAL has focused our expertise in four complementary areas to achieve this goal:

- The development of technological solutions based on **'just innovation'**
- Manufacturing of vacuum pumps and suction cups in **France**,
- Distribution of the range by our **sales team, 4 subsidiaries, and a network of selected distributors**
- **Service before and after** the launch of the product to: analyze the application, aid in decision making, and train users.

COVAL is a company which shares with its customers its values of **technical know-how, productivity, commitment, flexibility, and responsibility.**

COVAL provides a comprehensive range of vacuum handling services for its customers - that's why COVAL employees are **Vacuum Managers.**

You require more than just vacuum

What distinguishes us is our capacity to provide you with a complete solution above and beyond just our products.

We are always able to analyse, propose, develop, manufacture and provide THE perfectly adapted solution to your needs.

This means we are **Vacuum Managers**, every day.

- Constant improvement of product and service quality
- Fast reactivity in developing new solutions
- The capacity to assist companies in new markets
- A global solution provider, including services before and after installation

COVAL supplies the different companies involved in the Aerospace industry with comprehensive management of vacuum handling for the manufacturing process as a whole: lifting, moving and clamping of plane parts.

COVAL solutions, such as vacuum pumps and suction cups, equip all the tooling used in the process of manufacturing, machining and assembly of the different sections that make up an aircraft.

The numerous processes required by the aerospace industry need technical skills, expertise, innovation, and service. To meet these challenges, COVAL relies on:

- A strong capacity for development and innovation
- A team 100% dedicated to the Aerospace industry
- A full product range integrating mechatronics for better productivity
- « Fully integrated » vacuum solutions
- Compliance with the strictest quality standards
- Presence in economic areas with strong potential, thanks to 5 subsidiaries



We are here to assist you from start to finish

AUDIT OF EXISTING
SYSTEM ADVICE



INSTALLATION



MAINTENANCE

COVAL, your partner for Aerospace applications

Materials that we handle

- Aluminum
- Titanium
- Composite materials: cured or uncured
- Fiberglass

Machines that we equip

- CNC machines
- Robot cells
- Lifting systems
- Assembly jigs
- Composite layup tables

Plane parts that we clamp

- Wings / Stringers
- Keel Beam
- Sub-assembly Center Wing Box (CWB)
- Horizontal stabilizers, HTP, VTP...
- Fuselage

We work with

- AIRBUS GROUP
- BEING
- BOMBARDIER
- DASSAULT
- EMBRAER
- STELIA

Equipment for robot cells

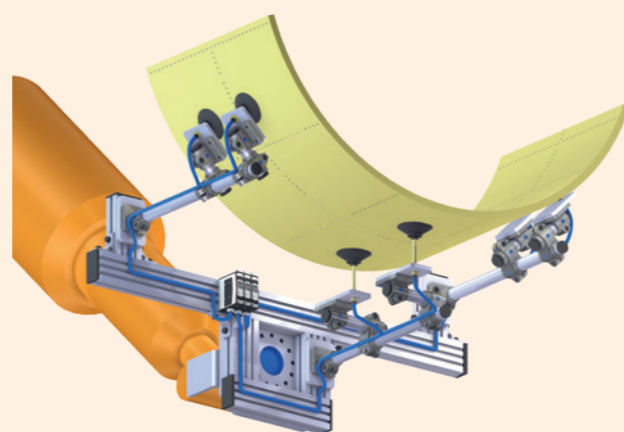

Integration of our vacuum solutions for robots:

- Compact and intelligent vacuum generators with fieldbus option, communication with PLC...
- Different flow rates depending on the types of parts handled
- Wide range of suction cups to equip end effectors, Ø 1 to 500 mm
- Specific suction cup materials for the Aerospace sector (resistance to cleaning agents, no particle migration, etc...)
- Different accessories for simplified mounting



- 1 C series high-performance suction cup on robot line.
- 2 Gripping a composite part before autoclaving.
- 3 Composite wing skin lifter.

Equipment for CNC machines

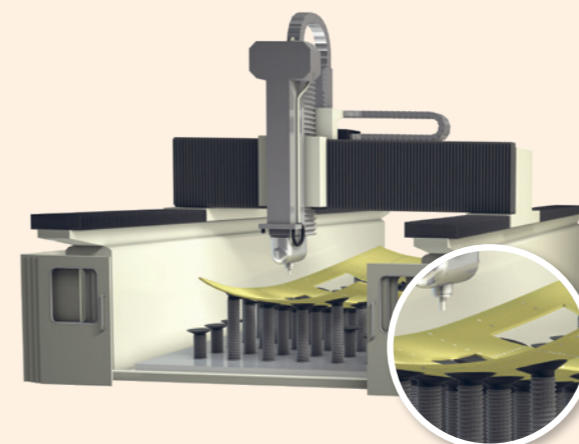

Specific clamping solutions for machining processes:

- Suction cups adapted to lateral stresses
- Rigid cleats inside the suction cups to ensure accurate positioning.
- Vacuum generators with an adjustable vacuum level depending on the thickness/material clamped in position by UHF/FLEXIBLE TOOLING
- Accessories for uneven surfaces

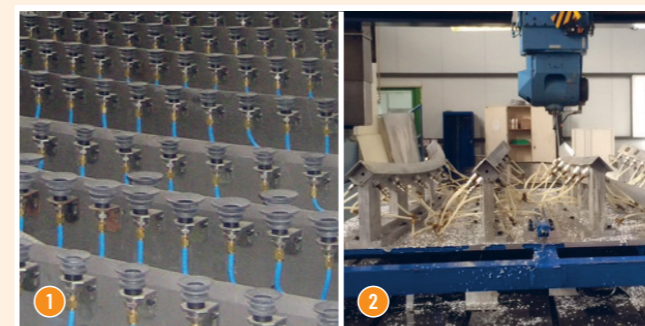

- 1 Horizontal clamp tooling placed in a CNC machine.
- 2 Clamping stringers.
- 3 Vacuum pumps and suction cups on UHF/FLEXIBLE TOOLING.

Equipment for assembly jigs

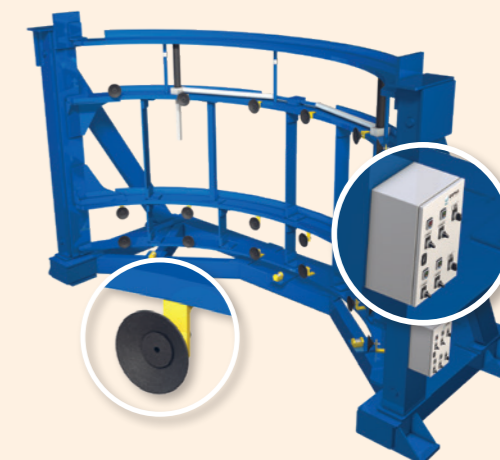

Vacuum clamping of plane parts on assembly jigs:

- Specific non-slip suction cups
- Pneumatic vacuum pump without air consumption: energy savings
- Turnkey vacuum box to activate clamping, zone by zone: helping to position parts
- Dimensioning and installation on pneumatic network tooling
- Safety integration to guarantee maintaining vacuum when moving tooling without energy



- 1 Clamping: nose section sub-assembly.
- 2 Suction cups on mechanical support : clamping lower shell.
- 3 Tooling on PREFAL A350.

A range and technologies to meet the needs of the Aerospace sector

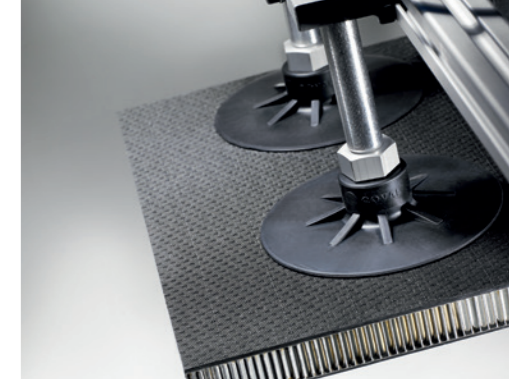

Suction cups

C series suction cups

- Optimized suction cups for gripping thin parts without deformation
- Ideal for vertical handling or clamping
- Non-slip cleats ensuring optimal positioning and clamping



Standard suction cups: VSA, VS, VPG, VPO

- Compatible with many types of materials
- Different standard materials available
- Large diameters: from 25 mm to 250 mm
- Round, oblong, flat shapes, with bellows



VPSC composite suction cup

- Gripping aeronautical parts made with uncured composite materials
- Gripping of folds after cutting
- Non-marking of composite part

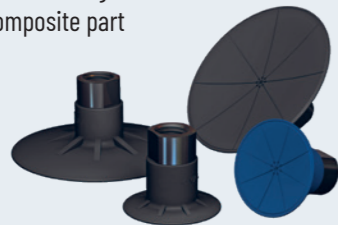

Vacuum pumps and Vacuum boxes

LEMEX - LEMAX IO - LEMAX+ - LEMCOM - GVMAX HD series

Mini vacuum pumps with « ASC » integrated

- Very compact and light
- More than 90% energy savings
- Operational silence
- Auto-adaptation depending on the material to be handled
- Optional fieldbus

Use

Handling all airtight or low porosity pieces



Vacuum box with integrated functions

- Integrated pneumatic or electrical vacuum pump
- Façade control console, with manual or automated activation of vacuum zones
- Visual alarm with a light
- Vacuum activation, sequence by sequence, helping to position a curved plane panel



Control box for compacting raw composite

- Regulate and control vacuum level
- Compacting time set by timer
- Automatic stop at end of cycle
- Visual indicator of vacuum level
- Audible alarm in case of vacuum loss



Accessories

L series extensions

- Ensure that the suction cups are fastened
- Make it possible to adjust the position of the suction cup on the tooling
- Guarantee airtightness of the assembly by using a coil fitting with an O-ring



Vacuum switches

Electronic, electric or pneumatic
PSD, PSK, PSA100, PSE, PSP



Spring systems

1/8G - 1/4G - 3/8G Standard or anti-rotation TS - YS - TSOP - TSOG



Vacuum filter

1/8G - 1/4G - 3/8G - 3/4G - 2" Filtering cartridge: paper, stainless steel or polyamide



Mechanical sensors

Enabling suction cups to be independent on the same vacuum network

- Activation of vacuum by contact with the part
- No risk of marking, thanks to material used
- No risk of marking very fragile parts



Vacuum lifters

COVAL proposes a range of vacuum lifters. Design and manufacture of customized handling solutions

- Horizontal, vertical, pivoting
- A variety of accessories to fit to any type of radius of curvature
- Loads: 50 kg to 3 tons
- Safety factor integration required in the event of power failure

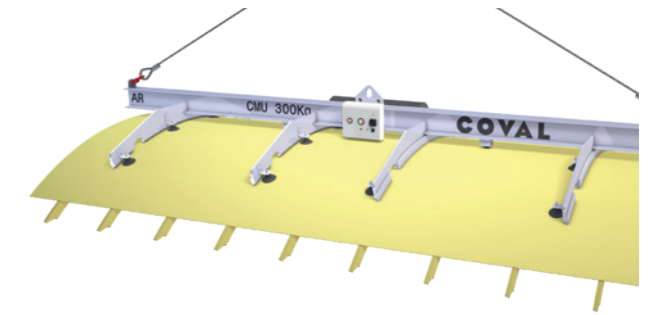

COVAL Global Services

Our goal is the efficiency of your installation from design to operation. To achieve this, COVAL works with its clients at every stage of the project to bring the most comprehensive solution possible:

- Software to help determine appropriate vacuum network (fittings, vacuum reserve, tubing)
- Supply of all necessary mounting elements for attaching our products to tooling
- Installation of complete solution on site
- Final tests and controls performed with the customer

A service that makes the COVAL team **Vacuum Managers** in your installation.

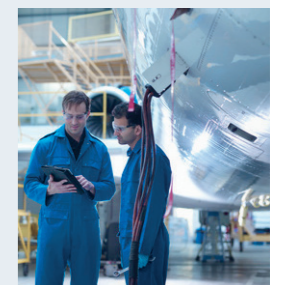

You will find our catalog and 3D CAD Models of all our products, on our website www.coval.com, or via our free downloadable Mobile apps.



COVAL

vacuum managers

vacuum components



A TECHNOLOGICAL PARTNER ON A GLOBAL SCALE

Located in the South of France, COVAL SAS designs, produces, and markets high-performance vacuum components and systems for industrial applications in all sectors worldwide.

An ISO 9001: V2015 certified company, COVAL innovates globally in vacuum handling. Our optimized components integrate intelligent and reliable functionalities, adapt to your industrial context, and safely improve your productivity.

With a strong spirit of innovation and technological advancements, the COVAL team is now recognized as an expert in developing reliable, economical, and productive custom solutions.

COVAL's references are found in major industrial sectors such as packaging, food processing, automotive, plastics, aerospace, and robotics, where vacuum handling is crucial for efficiency and productivity.

COVAL markets its products and services worldwide through its subsidiaries and authorized distributor network. Always attentive to its customers, COVAL supports the implementation of its solutions with a continuous and attentive relationship.

Visit the following section on COVAL's website:
contacts > commercial network
to view the most current list.



COVAL S.A.S.
Head Office



COVAL INC.



COVAL IBERICA



COVAL ITALIA



COVAL CHINA

Distributed by:



Certified quality
management system

COVAL VACUUM TECHNOLOGY INC.

901 Jones Franklin Road
Raleigh, NC 27606
Phone : (919) 233-4855
Fax : (919) 233-4854

www.coval-inc.com